













157

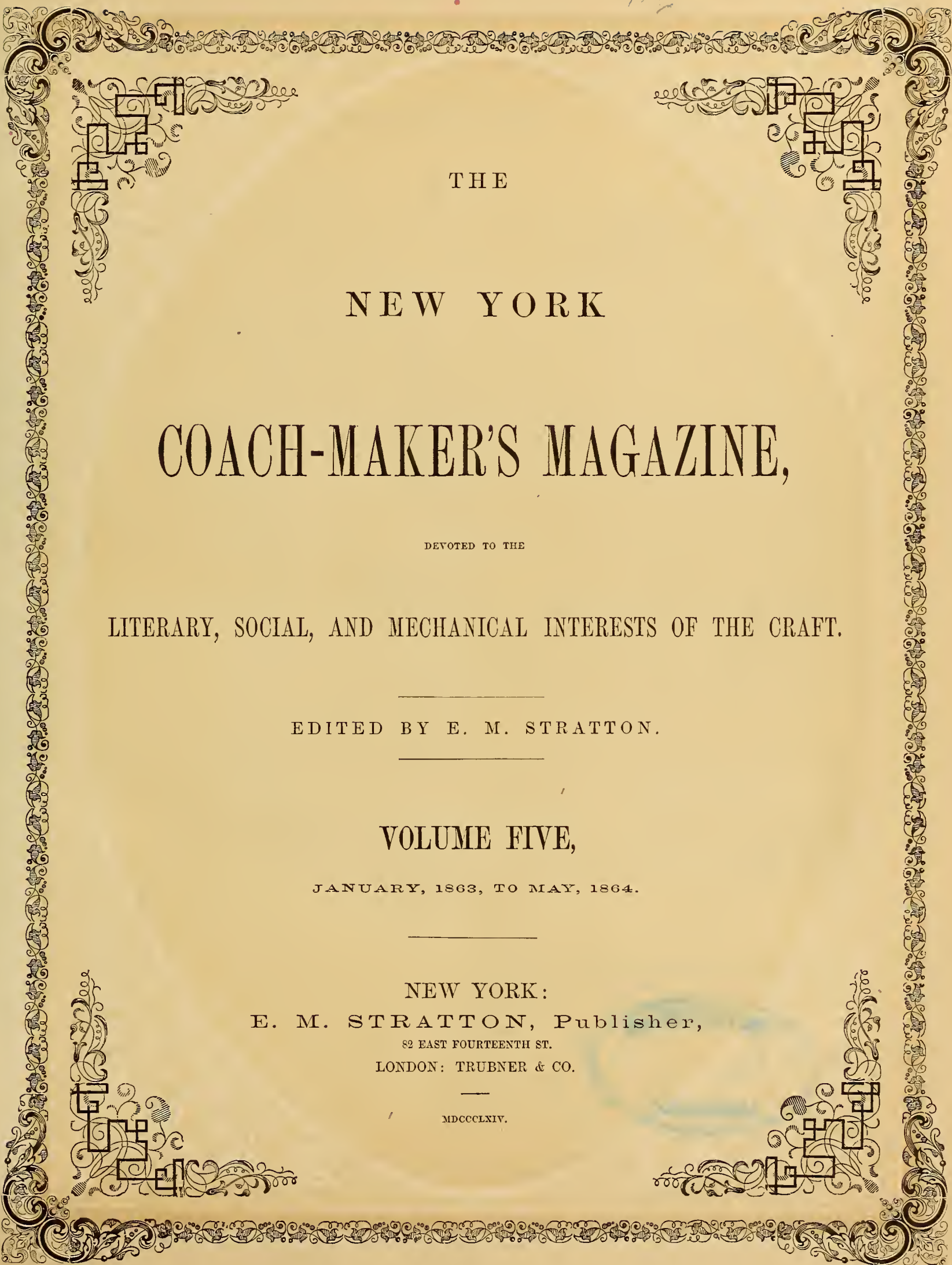

THE  
NEW YORK  
COACH-MAKER'S MAGAZINE,

DEVOTED TO THE  
LITERARY, SOCIAL, AND MECHANICAL INTERESTS OF THE CRAFT.

---

EDITED BY E. M. STRATTON.

---

VOLUME FIVE,  
JANUARY, 1863, TO MAY, 1864.

---

NEW YORK:  
E. M. STRATTON, Publisher,  
82 EAST FOURTEENTH ST.  
LONDON: TRUBNER & CO.

---

MDCCCLXIV.

TS 2001

N48

MHT/PO

22/28





## P R E F A C E .

---

IN publishing this Fifth Volume of THE NEW YORK COACH-MAKER'S MAGAZINE, eighteen months have been consumed, and with its completion, six years have passed away since the first number was given to the public. During that period, Coach-making in this country has undergone many changes—from depression to comparative prosperity—from scarcely any demand for carriages, to such a demand that it is with much difficulty it can now be supplied; and this state of things, too, singular as it may appear, is all owing to the civil war raging within our own borders! Well may other nations look on and wonder.

We are happy to say, that while publishing this volume, our circulation has greatly exceeded that of the one preceding it, and this gives us ground for further encouragement, notwithstanding that for the past three years the Publisher has realized very little profit, pecuniarily, for his labors. This is owing to the fact that the costs of production have doubled, while our charges for subscription were advanced only twenty-five per cent. We have the satisfaction, however, of knowing that our labors have met with the cordial approbation of our readers, and this, to us, is a somewhat satisfactory reward for our toil. Besides this, we have gathered around us a crowd of esteemed friends, whose friendship is worthy of the name. That the kindness they have extended to us, while we have been using our humble endeavors to please, may meet with a fitting reward, is our heart-felt wish.

Much practical matter, such as can be obtained nowhere else, will be found in this volume, supplied by talented correspondents. To them, we tender our sincere and warmest thanks, and an invitation to continue their favors in the future, for however diligent an Editor may be in conducting a work of this kind, still he is, and must always be, indebted for much of his success to intelligent writers.

We flatter ourselves that we have been more successful in selecting the drafts for this, than for either of the volumes preceding it, and have likewise been able to gratify our subscribers by giving them more light carriages. We intend, in the coming volume, if possible, to still further improve in this particular, and leave no cause for complaint, if an indomitable will and persevering industry can accomplish our purpose. Trusting that our readers will bear with the trifling advance the times compel us to make on the next volume, we still remain,

Yours sincerely,

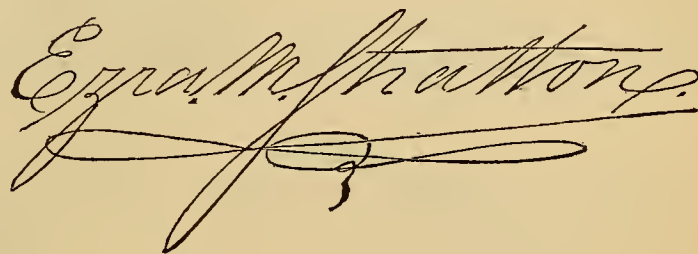

NEW YORK, *April 16th*, 1864.

## INDEX TO PLATES IN VOLUME FIVE.

DIRECTIONS TO THE BINDER.—The Portrait of the Editor to face the title-page. The Draft, Ornamental, and other Plates, are all to be placed at the end of the volume, in the order as numbered.

PLATE.

1. English Landau.
2. Gig Wagonette.
3. Light Buggy.
4. Four Ornamental Designs.
5. Belgian Caleche.
6. Single-horse Coupé.
7. Half-cut-under Phaeton.
8. Round-cornered Buggy.
9. Four-in-hand Drag.
10. Family Coupé.
11. Scroll Buggy.
12. Four Original Ornamental Designs.
13. Sociable Wagonette.
14. Phaeton for Four Passengers.
15. Berlin Sporting Wagon.
16. The Coal-box Buggy.

PLATE.

17. Canadian Family Sleigh.
18. Phaeton Sleigh—Four-seated Country Sleigh.
19. Truck Wagon for City use.
20. A Gig Body Geometrically Drawn.
21. Somerset Caleche.
22. Sporting Phaeton.
23. Lincoln Buggy.
24. Three Original Ornamental Designs.
25. Coupé for Six Passengers.
26. American Victoria.
27. The Decomeo.
28. Compass-front Coupé.
29. Extension-top Barouche.
30. New York Box-Buggy.
31. Newport Cart.

PLATE.

32. Drag-front Coach.
33. Tilbury Phaeton.
34. Caned Go-Cart.
35. Harper's Axle-Scale and Gauge.
36. Break.
37. Single-horse Coupé.
38. Pony Phaeton.
39. Tilbury Buggy.
40. Four-passenger Coupé Rockaway.
41. Coal-scuttle Buggy.
42. Ribbed Buggy.
43. Ornamented German Text.
44. Dépôt Wagon.
45. Bracketed Coal-box.
46. Caned Buggy.

## INDEX TO ILLUSTRATIONS.

	PAGE.
Portrait of E. M. Stratton. <i>Frontispiece.</i>	
Diagrams for round-cornered Seats. (2 illustrations.)	3, 4
Iron Check-loop.	9
Anti-rattling Fifth-wheel.	9
Buggy Linings.	11
Scale for cross-measurements on the Cant-board.	23
Self-adjusting Carriage Spring. (2 illustrations.)	26
New Application of the C-spring.	26
Linings for a Board Seat.	28
Boxes, and set of Axles. (2 illustrations.)	35
Iron Wheel.	37
Trimmings for Lazy-backs. (2 illustrations.)	43
Gather in Axles. (2 illustrations.)	51

	PAGE.
The Carpentum. (2 illustrations.)	51
Machine for Improving Roads.	52
Trimming for the front of a Coupé.	57
Roman Currus.	66
Roman Rheda.	67
Private Hansom, with Cant-board. (English.)	70
Barouche, with Cant-board.	83
Roman Pilentum.	84
Roman Chariot.	85
Trimming the back of a Buggy. (2 illustrations.)	89
Carriage Lamp.	92
Diagram showing the Leverage of Wheels. (3 illustrations.)	99, 114, 115
Roman Cisium.	100
Roman Triumphal Chariot.	101
Pole and Yoke for a Buggy.	105

	PAGE.
Stage-coach.	119
Plating the Coupé Rocker.	121
Pompeian Wine-wagon.	132
Diagram illustrating the Dish of a Wheel.	133
Pompeian Swan-shaped Car.	147
Pompeian Chariot.	148
Six-wheeled and four-wheeled Wagons, how turned, &c. (3 illustrations.)	149, 150
Why Wheels are Dished. (2 illus.)	162
Miles' Wagon-st ke.	170
Frame for setting Axle Boxes.	179
Diagrams showing why "Talking" Wagons are defective. (3 illustrations.)	180, 181, 182
Fore Carriage for a Phaeton.	184

NOTICE

AFTER CAREFUL EXAMINATION OF THE  
INNER MARGIN AND TYPE OF MATERIAL  
WE HAVE SEWN THIS VOLUME BY HAND  
SO IT CAN BE MORE EASILY OPENED  
AND READ.

## INDEX TO PLATES IN

DIRECTIONS TO THE BINDER.—The Portrait of the Editor to face the title-page. The D  
volume, in the order as numbered.

### PLATE.

1. English Landau.
2. Gig Wagonette.
3. Light Buggy.
4. Four Ornamental Designs.
5. Belgian Caleche.
6. Single-horse Coupé.
7. Half-cut-under Phaeton.
8. Round-cornered Buggy.
9. Four-in-hand Drag.
10. Family Coupé.
11. Scroll Buggy.
12. Four Original Ornamental Designs.
13. Sociable Wagonette.
14. Phaeton for Four Passengers.
15. Berlin Sporting Wagon.
16. The Coal-box Buggy.

### PLATE.

17. Canadian Family Sleigh.
18. Phaeton Sleigh—Four-seated Country Sleigh.
19. Truck Wagon for City use.
20. A Gig Body Geometrically Drawn.
21. Somerset Caleche.
22. Sporting Phaeton.
23. Lincoln Buggy.
24. Three Original Ornamental Designs.
25. Coupé for Six Passengers.
26. American Victoria.
27. The Decomeo.
28. Compass-front Coupé.
29. Extension-top Barouche.
30. New York Box-Buggy.
31. Newport Cart.

### PLATE.

32. Drag-front Coach.
33. Tilbury Phaeton.
34. Caned Go-Cart.
35. Harper's Axle-Scale and Gauge.
36. Break.
37. Single-horse Coupé.
38. Pony Phaeton.
39. Tilbury Buggy.
40. Four-passenger Coupé Rockaway.
41. Coal-seattle Buggy.
42. Ribbed Buggy.
43. Ornamented German Text.
44. Depot Wagon.
45. Bracketed Coal-box.
46. Caned Buggy.

## INDEX TO ILLUSTRATIONS.

	PAGE.		PAGE.		PAGE.
Portrait of E. M. Stratton. <i>Frontispiece.</i>		The Carpentum. (2 illustrations.)	51	Stage-coach.	119
Diagrams for round-cornered Seats. (2 illustrations.)	3, 4	Machine for Improving Roads.	52	Plating the Coupé Rocker.	121
Iron Check-loop.	9	Trimming for the front of a Coupé.	57	Pompeian Wine-wagon.	132
Anti-rattling Fifth-wheel.	9	Roman Currus.	66	Diagram Illustrating the Dish of a Wheel.	133
Buggy Linings.	11	Roman Rheda.	67	Pompeian Swan-shaped Car.	147
Scale for cross-measurements on the Cant-board.	23	Private Hansom, with Cant-board. (English.)	70	Pompeian Chariot.	148
Self-adjusting Carriage Spring. (2 il- lustrations.)	26	Barouche, with Cant-board.	83	Six-wheeled and four-wheeled Wag- ons, how turned, &c. (3 illus- trations.)	149, 150
New Application of the C-spring.	26	Roman Pilentum.	84	Why Wheels are Dished. (2 illus.)	162
Linings for a Board Seat.	28	Roman Chariot.	85	Miles' Wagon-stroke.	170
Boxes, and set of Axles. (2 illustra- tions.)	35	Trimming the back of a Buggy. (2 il- lustrations.)	89	Frame for setting Axle Boxes.	179
Iron Wheel.	37	Carriage Lamp.	92	Diagrams showing why "Talking" Wagons are defective. (3 illus- trations.)	180, 181, 182
Trimming for Lazy-backs. (2 illus- trations.)	43	Diagram showing the Leverage of Wheels. (3 illustrations.)	99, 114, 115	Fore Carriage for a Phaeton.	184
Gather in Axles. (2 illustrations.)	51	Roman Cisium.	100		
		Roman Triumphal Chariot.	101		
		Pole and Yoke for a Buggy.	105		

## INDEX TO VOLUME FIVE.

TO THE READER.—Under the different heads of HOME CIRCLE, SPARKS FROM THE ANVIL, PAINT ROOM, TRIMMING ROOM, EDITOR'S WORK-BENCH AND LETTER-BOX, will be found arranged, in alphabetical order, such matter as properly belongs to such departments.

	PAGE.		PAGE.		PAGE.
A Comprehensive Ancient Patent,	31	Chariot, Ivory, of Mermicides, 71; Napier's Battle,	92	EDITOR'S WORK-BENCH— <i>Concluded.</i>	
Advance in Price,	102	Comments on the Fashions,	74	Volumes Bound, and Covers	
A Long Stage Route,	79	Cottages on Wheels,	109	for Volumes,	158
A New Idea,	109	Coupé, Compass-front, 120; Family,		Wind-power for Machinery,	142
A Novel Whiffle-tree,	14	40; For Six Passengers, 104;		Wolves Among the Craft,	107
American Institute, Fair of the,	79	Single-horse,	25	Editor's Portrait, Notice of,	82
American Victoria,	105	Crying in Olden Times,	132	Enterprising,	40
Another Steam Carriage,	126	Decomeo, The,	105	Equipages, Shabbiness of Victoria's,	62
Ancient Anvil,	79	Dish of Wheels, and Taper of Axles		Exchanges, To Our,	173
An Editor in Distress,	91	Relatively Considered,	34	Facts about Railroad Speed,	126
Atlantic Monthly, The, 14, 47, 62, 79, 92,		Dog-carts, Genuine,	62	Go-cart, Caned,	137
126, 142, 159, 174		Drag, Four-in-hand,	40	Gather in Axles, Reasons for the Ne-	
Axle Grease, Recipes for Compounding,	92	Editorial Autobiography,	97	cessity of,	50
Barouche, Extension Top,	120	Editorial Chips and Shavings, 14, 31,		Gig Body, Geometrically Drawn,	73
Bill Jingle Imitated,	159	46, 62, 78, 91, 109, 126, 159,		Gig Wagonette,	8
Break,	153	173,	186	Guage for Setting Axles (Harper's),	
Buggy, Bracketed Coal-box, 184;		Editorial Perplexities,	125	14, 62, 159	
Caned, 184; Coal-scuttle, 169;		EDITOR'S WORK-BENCH:		Historical and Genealogical Register	
Light, 9; Lincoln, 87; Ribbed,		Abandoned Inventions,	29	and Antiquarian Journal, N.	
169; Round Cornered, 26; The		A Clean Shop and Things in		E., 62, 79,	159
Coal-box, 55; Tilbury, 153;		Place,	172	Historical Magazine (Notice of),	174
New York Box, 120; Scroll,	40	Advice to Carriage-makers,	43	Horses, Bedding for,	23
Buggies, Fashions in,	29, 148	American Carriage-making,		HOME CIRCLE:	
California, Mineral Paints of,	126	Commercial Review of,	90	A Tale for the Times,	7
Caleché, Belgian, 25; Somerset,	87	Canadian Exhibition of Car-		An Interesting Story (An-	
Cant-board, Rule for taking Cross-		riages and Materials,	125	nonouncement of),	73
measurements on the,	22	Carriage Body-making,	156	Deserter, The; A Story of the	
Carriage Architecture, English,	70, 83	Carriage-makers' Dissatisfac-		Mexican War, 151,	167
Carriage-builders' Art Journal,	79	tions,	91	Faith Whispers (Poetry),	69
Carriage Drive, Seventh Avenue,		Carriage-making, The Future		Fairy Coronation, The,	168
(N. Y.)	92	of,	108	Taxes,	169
Carriage Fare, Livery Stable Increase		Carriages and the Revenue		Light From Afar (Poetry),	53
in,	186	Tax,	44	Mildred: A Sketch,	39
Carriage Factory, Largest in the		Coach Factory, Half Centennial		Journeyings of a Whirlwind,	71
World,	78	Anniversary in,	60	Lottie Hill, 85, 102,	134
Carriage-maker, Sudden Death of an		Emptying the Purse into the		Mrs. Mayweed's Auction Sale,	24
Old,	173	Head,	157	Mysterious Knockings (Poetry)	53
Carriage-making, A Decade of Eng-		English Vandalism,	29	Niagara River, from Goat Isl-	
lish, 82; In San Francisco,	83	Family Carriage Wanted,	173	and (Poetry),	23
Carriage Materials, Current Prices		Fashions in Buggies,	29	Now and Then: A Life Scene	
for, 32, 48, 64, 80, 96, 112, 128,		Proposed Coach-makers' Pro-		(Poetry),	134
144, 160, 176,	188	jective Association,	12	Thirty-five (Poetry),	85
Carriage Wheels, Their Mechanical		Greetings,	124	To Fannie (Poetry),	39
Construction and Use Consider-		Hobson's Livery Stable,	142	Was It Well? (Poetry)	11
ed,	113, 133, 145	Leakage Somewhere,	171	Welcome to the Blue-bird (Po-	
Carriages, Ancient Roman, 51, 66, 83,	100	Omnibuses <i>vs.</i> The Public,	186	etry),	151
Carriages, Compound Tire for,	46	Our Present Number,	13	International Exhibition, Catalogue	
Carriages, Foreign Improvements in,		Paying Workmen in Store Or-		of the,	46
13, 45, 63, 93, 109, 127, 142,		ders,	91	Inventions Relating to Coach-making,	
174,	187	Picture Advertising,	44	American Patented, 15, 47, 79,	
Carriages, Advance in the Price of,		Revenue Tax, How it Affects		94, 111, 127, 143, 159,	174
102; And the Revenue Tax,		Carriage-making,	61	Iron Wagon Companies, 109; Car-	
44; Excise License on, in Eng-		Review of Trade,	158, 172	riage Hubs,	109
land, 69; Income Duty on, 14;		Scientific Stupidity,	14	Lamps, The Best Place to Buy your,	92
Report of, in the London Inter-		Shifting Rails Once More,	78	Landau, English,	8
national Exhibition of 1863,		Slow Coach-makers,	140	Law of the Road, 14,	31
49; The Value of English, in		The Situation,	28	London by Gas-light, 31; The New	
America,	78	To Our Friends,	12, 90	Tariff Regulations for the City	
Carriages, Canadian Patents in,	187	To Our Readers,	186	of,	126
Carrying the Mails in Olden Times,	53	Union Necessary,	158		
Cart, Newport,	120	Unrealized Happiness,	141		
Coach, Drag-front,	136	Visit to Canada,	58, 76		
Coaches, An Advertisement about the					
Patent for Easy,	147				

	PAGE.		PAGE.		PAGE.
LETTER Box, The Coachmaker's:		Sand-paper,	132	Tireville Miscellany, The; Being selections from the Journal of John Stillwagen, Esq., 1, 32, 65, 81,	116
Letter from Wisconsin,	126	"Secesh" Historical painting in which a Coach figures,	174	TRIMMING ROOM:	
Letter from Illinois,	187	Setting Axle boxes,	178	Buggy, Trimming the back of a,	89
Literary Notices, 14, 47, 62, 78, 92, 126, 142,	159	Sleigh Canadian Family, 73; Four-seated country, 73; Phaeton,	73	Carriage-Laees,	171
Monthly Issues Resumed,	92	Sleigh-driving in Russia,	46	Carriage-Trimnings, Extraordinary rise in,	156
Nails, why called Sixpenny,	49	SPARKS FROM THE ANVIL:		Carriage-Tops, Mixture for reviving the Leather of,	171
New rendering of an old quotation,	109	Carriage-Springs, Self-adjusting,	26	Coupé, Ornamental Trimming for the front of,	57
New York, number of vehicles in, 62; Old roads of,	70	Carriages, Draught of,	137	Dirt-screens over Car'ge-Wheels,	110
Never Trouble Trouble,	119	Case-hardening Iron,	40	Enameled Cloth,	28
One respectable Carriage in Dixie,	31	Cast-iron, Malleable,	153	Fashions, Review of the,	124
Paddy's Poetical Horse,	92	Cast-steel, Composition for welding,	40	Gossip for the Trimmer,	140
PAINT ROOM:		C-springs, New application of,	26	Hammer Cloth, Origin of the word,	107
About Sponges,	10	Check-loop Iron,	9	Harness Blacking, 185; Care of,	57
Colors, Permanent and Fugitive,	138	Files, Machine cut, English, 88; Rendering them again useful, 138; Use and abuse of,	74	Lazy-backs, Fashionable Trimming for,	42
Linseed-Oil,	78	Fifth-wheel, Another Anti-rattling,	9	Lining Buggies, Improved mode of,	10
"    " and bad Turpentine,	170	Fore-Carriage for a Phaeton,	184	Linings for a board seat,	28
National Coach-painters' Association,	42	Hardening Iron and Steel,	55	Lustrolæ, Or Leather Varnish,	89
Ornamental Designs,	10, 42, 89	Hoop-tire, Changes effected by Heating and Cooling,	87	Testing Blues in Cloth,	140
Ornamental German Text,	171	Iron, Defects in, 55; In New York, 121; Probable Rise in,	105	The Fashions,	185
Paints, Composition of, 27, 41, 56, 74, 106, 122, 154,	184	Lubricating Compound,	40	Trimnings, Extraordinary rise in, 156; Great rise in the price of, 124; Observations on the present style of,	75
Reservoir Paint Brush,	171	Plating the Coupé Rocker,		Truck Wagon for city use,	73
Turpentine, Where it comes from, 57; Bad,	170	Pole and Yoke for a light Buggy,	105	United States Tax Law, A Hand-book of the,	47
Ultramarine Blue,	88	Rust, How metallic surfaces are protected from,	74	Value of the Coach-maker's Magazine to the Craft,	62
Varnish-dealers, Dishonest,	10	Scale for setting Axles, H. Harper's,	137	Wagenbau Zeitung, (Notice of),	126
Varnishes, Stimson, Valentine & Co's.,	88	Steel, Besmer's Improved, 9; Cementation of,	74	Wagon, Berlin Sporting, 55; Depot, 184; Truck for city use,	73
Perambulators in London,	38	Steel Tires, Composition for Welding and Restoring Burnt,	40	Wagons, Talking,	179
Prairie Motor, The,	31	To Distinguish Iron from Steel,	55	Wagon-makers and Blacksmiths in Dixie,	14
PEN ILLUSTRATIONS OF THE DRAFTS, 8, 25, 40, 55, 73, 87, 104, 120, 136, 153, 169,	184	Tire Irons,	105	Wagonette, Gig, 8; Sporting, 87; Suitable,	55
Personal,	173	Wagon Stake, Miles,	169	War, The First Year of the,	79
Phaeton, Half-cut under, 25; For Four Passengers, 55; Mrs. Governor Yates, 78; Pony, 153; Tilbury,	136	Special Notice,	176	Wheel-carriages, The Motive-power of, 18, 37, 49,	67
Pompeian Roads and Carriages,	131, 147	Spirit of the Times, a Comedy,	120	Wheel-carriages, Effects of, on Roads and Horses, 98, 117, 129, 148, 162; Improvements in,	161
Power applied for,	46	Talking Wagons,	179	Wheels, Why Dishd, 161, 177; Of Iron and Wood,	36
Power of Axles in overcoming Obstructions Examined,	235	Taxes,	169	Who are Nature's Noblemen?	46
Rioters and the Craft,	78	The lightest yet,	126	Wholesale seizure,	159
Roads, On repairing and improving, 52; Of old New York, 70; Noise from Carriages on Paved,	173	Timber, The best time to cut,	126	Yankees, The London Mechanics' Magazine on,	62
Rockaway, four-Passenger Coupé,	169	To Our Readers,	186		
Round corners, How formed,	3	Travel, Western, In olden time,	31, 92		
Rural New Yorker, (Notice of),	93	Traveling, Night and Day,	159		
Safety-skid Poetry,	31	Traveling Office, A Military Officer's,	173		



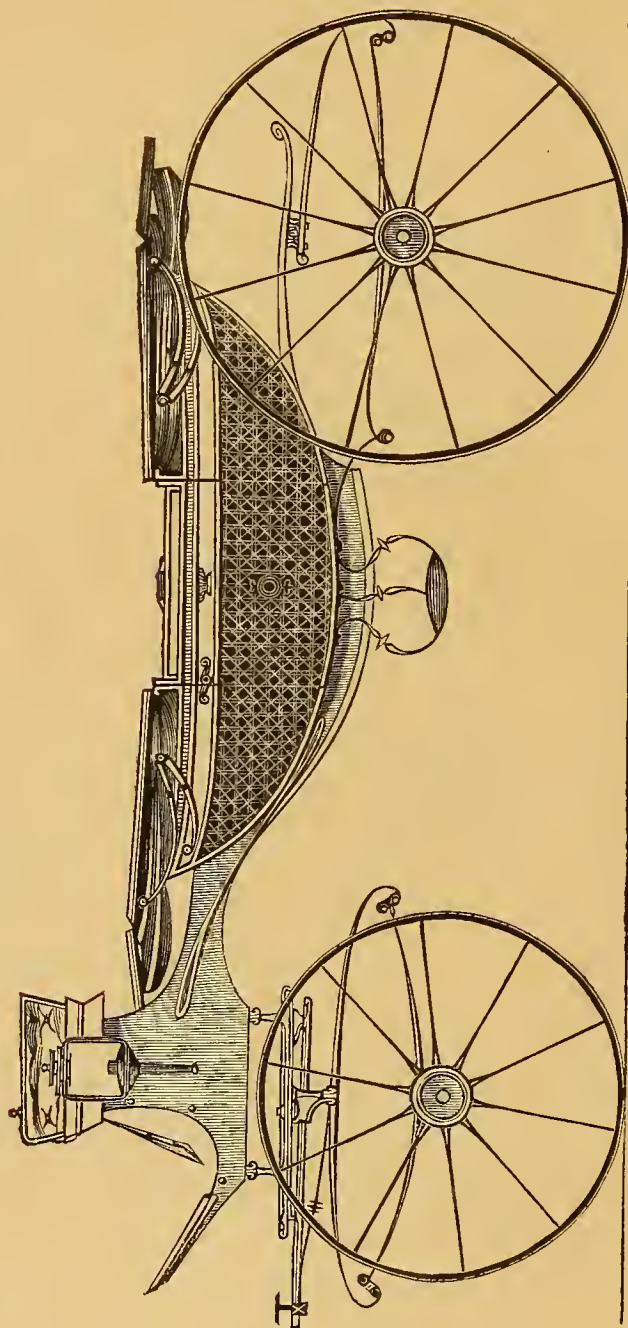

ENGLISH LANDAU.— $\frac{1}{2}$  IN. SCALE.  
*Engraved expressly for the New York Coach-maker's Magazine.  
Explained on page 8.*



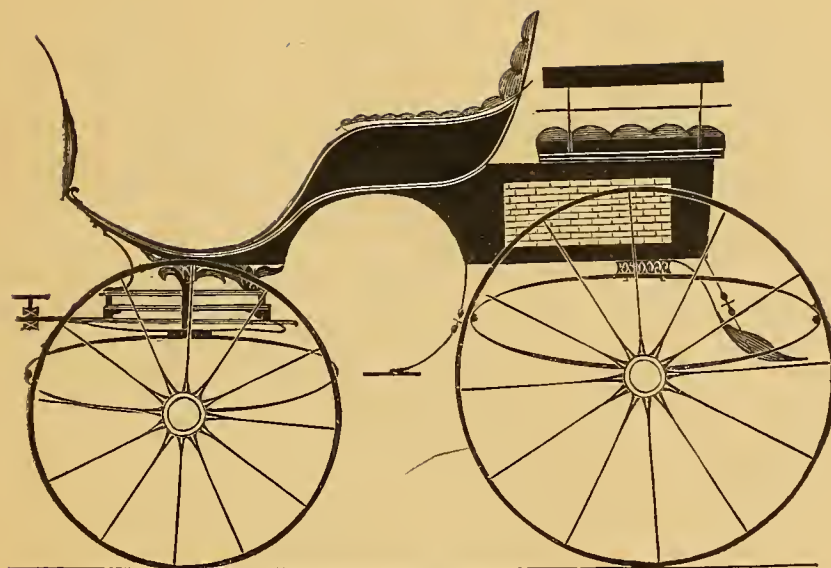

GIG WAGONETTE.— $\frac{1}{2}$  IN SCALE.

*Engraved expressly for the New York Coach-maker's Magazine.*

*Explained on page 8.*





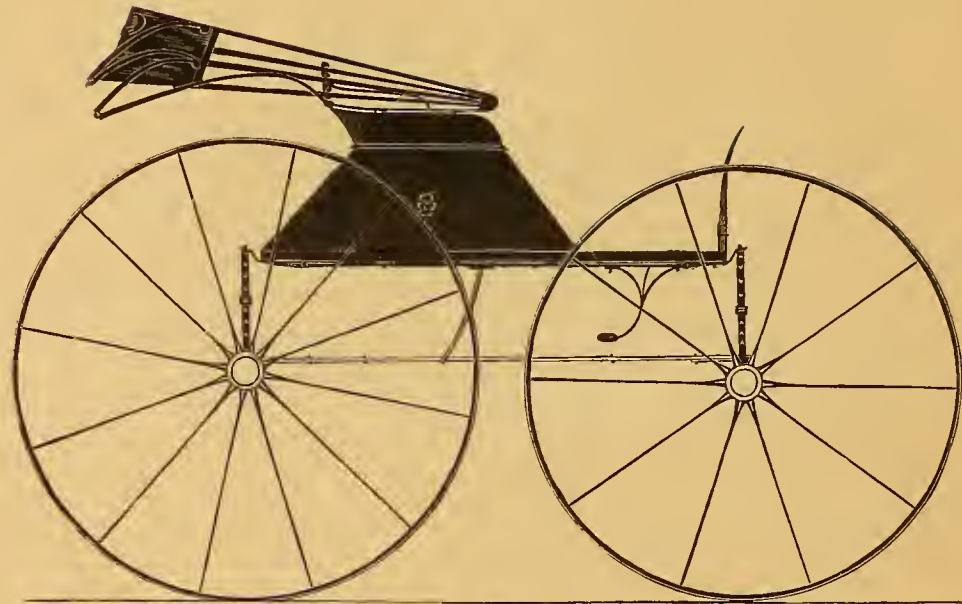

LIGHT BUGGY.— $\frac{1}{2}$  IN. SCALE.  
*Engraved expressly for the New York Coach-maker's Magazine.*  
*Explained on page 9.*



No. 1.



No. 2.

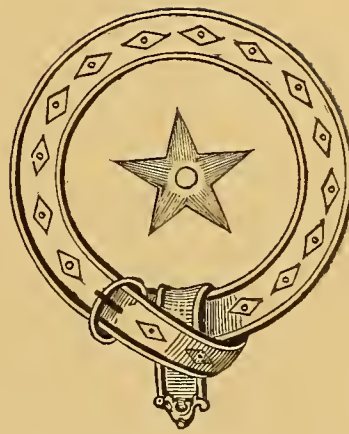

No. 3.



No. 4.

ORNAMENTAL DESIGNS.

*Engraved expressly for the New York Coach-maker's Magazine.*

*Explained on page 10.*





DEVOTED TO THE LITERARY, SOCIAL, AND MECHANICAL INTERESTS OF THE CRAFT.

Vol. V.

NEW YORK, JANUARY, 1863.

No. 1.

## Mechanical Literature.

### THE TIREVILLE MISCELLANY;

BEING SELECTIONS FROM THE PRIVATE JOURNAL OF JOHN  
STILWAGEN, ESQ.

BY THE EDITOR.

Our readers will very naturally ask, Where is Tireville? How did the Editor come into possession of Stilwagen's journal? and perhaps a dozen other questions, all equally excusable. These questions can only elicit from us the unsatisfactory reply that, for a special object, they have been placed in our hands by a party who, for the present, stipulates that we keep that matter a profound secret; assuring us, upon the honor of a gentleman, that the papers are the genuine reflex of the experience and difficulties attending a lifetime, while conducting the carriage-making business in Tireville. The apparent genuineness of the document, and the responsibility of the party to whom we are indebted for the favor, commend them to the study of the carriage-making fraternity, and must answer as an apology for their appearance here.

SELECTIONS FROM THE JOURNAL OF J. STILWAGEN.

April 2, 18—. Five years and three weeks an apprentice! Three years a journeyman slave!! Eight years of miserable suffering, endured to enrich others!!! I have now resolved to set up business for myself, determined hereafter to be my own master, in the hope of bettering my prospects, and thereby satisfying the wants of a young family, already crying for bread; for I perceive that *these* bosses are apparently an independent class—they work only when they are inclined to (which is not very often), and when they choose they hang about the premises solding their employees, or talking politics with some neighbor as lazy as themselves, while for their comfort and benefit the poor jours are obliged to shove the jack-plane from morning until night, expending their life's-blood simply to enrich a set of contemptible drones! After eight years *wasted* in slavery, I have resolved to act as my own master. If I cannot get rich soon, I am still

vol. v.—1

determined to live in independence. What is the use of living, if one can't enjoy life? What is the object of business, if not to get rich?

Five hundred dollars a year rent! Old Squeezetongs must have very *lofty* ideas of the carriage business, to suppose that a tenant will be able, from the profits of the first year's business, to pay that amount for the use of a shop in the village of Tireville, while there are already three more factories, within the circumference of one and a half miles, in operation. But here goes! "Nothing venture, nothing have," is an adage older than I am. Then, again, this *may be* "the tide in my affairs" following the stream of which may soon lead me into a fortune. It will not do to be afraid to venture. Lack of courage has already kept me dependent, at least for the past two years, upon others.

April 28.—Fairly installed! Let me see—I must have some *taking* name for this shop, for although many persons at different times have, in apparent sarcasm, asked "What's in a name?" there has never been but one correct response, "Much, very much." "The Union Carriage Factory." That sounds well enough, but its appropriateness is very doubtful just now. It will do after this establishment swallows up those of my neighbors at Scrabble-hill and Shintown. But I am in favor of some less objectionable term to Southern customers, and at the same time have a comprehensive one; the more particularly so since I intend that my competitors shall *comprehend* that mine is to be *the* carriage establishment. I am resolved, therefore, to call mine The Globe Carriage Factory. That term, "Globe," will fix the business, and let everybody know that I am prepared to receive the custom of "all the world and the rest of mankind." If that does not *take* orders in large numbers, then my faith in names will fail, and all my prospects of success fade away. Let it then be

THE GLOBE CARRIAGE FACTORY.

JOHN STILWAGEN, PROPRIETOR.

May 10.—Very singular—isn't it?—how a man is noticed as soon as he hangs out his shingle! Might have remained in obscurity still, *if I had remained a slave*. Now, everybody wants to know how I am getting along, and some even ask if I do not wish to buy stock. There was a time they would scarcely look at me; now, they are not backward in speaking. It is wonderful how some

folks' attentions have increased since the appearance of that "shingle"!

June 16.—I was visited this morning by "a honey-lipped" patent agent, who urged me, *in soft terms*, for an hour or more, to purchase of him a town right to use and sell Cheatem's Corrugated Frictionless Axles, warranted to run a whole year ungreased, and possessing *within themselves* more motive-power than any other six set of axles ever made. Told him he might call again at a future day when I got under full headway in business, hoping thereby to "bluff him off." Prayed, as he left the door, that he might forget to call on me again.

July 7.—The agent for Cheatem's Frictionless Axles was around again this morning, to "see if I had concluded to buy, as I had intimated a few days ago." Told him I had never *intimated* such a desire. On this occasion he presented a long list of recommendations from squires, honorables, lawyers, and others who had used them, *all well qualified to judge of such articles*—perhaps. Informed him that I was too busy just then to give him my attention. I wonder how these fellows ever find anybody willing to listen to their twaddle. They evidently are impressed with the idea that "the fools are not all dead yet," and under this conviction they persevere. Bored with his importunities, I finally told him, in plain English, "*his room was preferable to his company.*" This gave offence, serving to rid me of his presence.

July 19.—Advertised in the *Village Screamer* "for a first-rate steady hand to iron carriages. None but good workmen need apply." Overrun with applications. The first (or among the first) was a fellow who had been "on a bender" for two weeks at least. Told him *he* would not suit. The next I knew a few years ago as a helper, and a poor one, too, who now came for the place of fireman. On inquiry, found he had just been "kicked out" from Shintown, where, under false representations, he had obtained employment, and during his labors on the first day had burned up two tires, broken off the arm of an axle, and made some ten pounds of scrap-iron. As scrap-iron was selling very low just at that time, I told him very emphatically I did not think hiring him would pay. The man took offence at this, and left. The third applicant was rather a stout-built man, whose best recommendation appeared to be that, as he said, "he was a sober, steady workman, and had worked for Mr. Naylor, of Dockport, at ship-smith work, for the last six years." In a lengthy conversation I tried to convince him that ship-smithing and carriage-ironing were two widely different branches of mechanical science. Regretted being obliged to spend so much precious time in discussing a plain question with a thick-headed journeyman, on a subject I supposed could be disposed of in two minutes. How *steadily* obstinate and persevering some persons are! Finally, after more than twenty applications, I succeeded in engaging a young man who said he could iron-off anything I might set him at. I tried him, and found him so smart that he stretched the four days' time he should only have taken, in ironing-off a buggy, into nine. I begin to suspect that, after all, the bosses *may* have some drawback to their pleasures.

July 29.—Had "a time" this morning with my blacksmith—such a time as is enough to make one sick of the carriage-business. The fellow told me, in an independent tone, that if I did not think he had done work enough in the last nine days to satisfy any reasonable man, *we* had

better separate at once. For his part he was not a-going to overtax his limbs *to make rich men richer!*

(To be continued.)

## POWER OF AXLES IN OVERCOMING OBSTRUCTIONS EXAMINED.

BY HENRY HARPER.

MR. EDITOR:—The two articles which appeared in the July number [page 156, Vol. IV.] of your Magazine, from Mr. Mears and Henry Harper, on the power of large and small axles in overcoming obstructions, although they agree in one point (that small axles are preferable), yet in every other point they disagree. Mr. Mears says the mechanical power which an axle uses in overcoming obstacles is "an inclined plane, more or less obtuse;" also that a large axle, with the accompanying irons, is heavier than a small axle. On the contrary, Harper says that the mechanical power "is purely and simply a lever power," and that the weight of a small axle is greater than a large one. Mr. Mears says that there is more rubbing surface between the box and axle of the large axle, which creates more friction to the large axle than to the small one. On the contrary, Harper gives it as his opinion that the extra rubbing surface which a large axle has does not increase the friction to any perceptible extent. They agree in one proposition, and disagree in three; which is not quite near enough for scientific investigation. Personally it will make no odds which of the two is correct; but when viewed as a scientific principle laid down to govern mechanics by, there will be no end to the mischief created, if both principles are received as authority.

Mechanical laws avail themselves of four different powers. These are—the lever, the screw, the wedge, and the inclined plane. The second and third mentioned powers might with some propriety be included in that of the inclined plane, but they cannot in any way be mistaken for the lever power.

The machine which we call a wagon, through the agency of some one of these powers, shows its mechanical construction by lifting a weight over a perpendicular obstruction with a less motive-power than the weight is of itself. For instance, if we place an obstruction to a wheel half an inch high, and the wheel weighs 1,000 pounds, if we do not use any mechanical power we have got to use 1,000 pounds of power to raise the wheel half an inch, over the obstruction; but we all know that we can raise 1,000 pounds in a wheel, over an obstruction of half an inch, with our own hand. Then we know that we have used mechanical power; and if it is a lever, we know that the laws that govern the use of the lever are entirely different from the laws that govern an inclined plane, and that what would facilitate one would retard the other. For instance, if we were called upon to help the horses to move a wagon over an obstacle which was too much for them to overcome unaided, we should not think we were helping much by going behind and pushing the wagon over, although by that means the motive-power which we might lay out would partake of as much leverage as the same amount of power that the horses laid out. The best advantage at which we could use our strength, would be to take hold of the wheel; and again, we almost in-



stinctively see the advantage of applying the power as near the top of the wheel as possible, because this would increase the leverage.

On the other hand, if this power was an inclined-plane power, and we were called upon under similar circumstances, instead of taking hold of the top of the wheel, we would take hold at the bottom of the wheel and draw until it slid over the obstacle. But this would be so much strength laid out in direct opposition to the lever-power, which we know would not help any. It would be an inclined-plane power, which is certainly a power; but when compared with the lever, it sinks into utter insignificance. I have no hesitancy in saying that the power used in a wagon wheel is simply and purely a lever-power, and that the uneven obstacles, or inclined plane, over which the wheels pass or ascend, is converted into the fulcrum on which that lever acts. It is true that friction is a waste of motive-power, but it would be unwarrantably enlarging mechanical powers to call it a power of itself.

With regard to a large axle being heavier than a small one, I do not think it a fair statement of the case. When we speak of a large axle, we mean one chiefly made of wood, which is of greater bulk but not so much heft as iron. To sustain the same load this is necessary. I have estimated that the small iron axle with the irons required to fasten the same to its place, will make it weigh 98 pounds more than the large one. It may be 98 pounds is too much, but certainly there is more weight in the small iron than the large wooden axle, and it is not meeting the question in a satisfactory way to argue on a contrary hypothesis.

With regard to friction being greater, where the same weight is moved on an equally smooth and large surface, than it would on a smaller surface, I believe it to be contrary to our every day's experience, and it would lead to unwarrantable conclusions to entertain such a theory. If the bearing on a large axle-box was cast so as to be two inches in width at each end of the axle-box, and the bearing was cast of the same width on each end of the small box, and when put to service it was found that the greater bearing or rubbing surface of the larger axle destroyed the motive-power, this fact, when so ascertained, would point out plainly a remedy which would be to reduce the bearing surface of the large axle. If that bearing was twice as great on the large axle as on the small one, all that would be necessary to reduce the bearing on the large one so that the bearing would be equal with the small one in surface, would be to reduce the width of the bearing that was cast on the inside of the large box from two inches in width to one inch, which would make them equal in the surface of the bearing and *friction*, according to theory. If reducing the rubbing surface diminished the friction in this case, and we narrowed it down again one half, it would have the same strength and only half as much rubbing surface as the small axle; and, according to this theory, a large axle would run easier, if properly constructed, than a small one. Any one can easily test the theory advanced by Mr. Mears, by drawing two bricks over a table, and if he find that it requires any more power to draw them when laid side by side than it does when one is laid on top of the other, then it will be conclusive that a greater surface creates a greater friction. On the contrary, if he finds the power required to draw them just the same, the idea of a greater surface creating a greater friction must be abandoned.

Mr. Mears says: "In the large axle, the power applied at its center brings the side of the axle in contact with the box at a greater distance from that center, and the center of gravity in the axle has more unsupported overhang than in the small one." I cannot understand this sentence to have any meaning whatever, unless it is admitted that the wheel is a lever-power. If it is a lever-power, and the lever-lines are as I have described them, then the center of the axle is the utmost length that can be given to the arm of the lever; and of course the nearer we apply the motive-power to the center of the axle, the longer arm we get to the lever; but I cannot see what the center of the axle has to do with friction on the outside of the axle.

I hope this subject will not be dropped until we all come to an unanimous understanding about the nature of the power used in moving loads on wheels, for it is as important as any of the primary rules to our trade.

### ROUND CORNERS—HOW FORMED.

BY THE EDITOR.

AN inspection will show that it is becoming very fashionable to finish carriages with round-cornered bodies and seats, as seen on Plate XXXVIII. and in many other examples in Volume Four. How these are made will interest a great many of our readers, who will very soon have occasion to form them. We will take the seat for our example.

We shall presume that the bottom or seat-frame has already been framed, grooved for the sides and back to set in, and the valance worked on the outer edges of the same according to fancy. We next shape the two end pieces and back, beveling the bottom edges and back corners to the required flare, with the understanding that the back-piece must extend the *whole length* of the groove, the end-pieces butting up against the back with a perfect fit, as shown in Fig. 1, care being taken to have the angles correspond exactly with the grooves in the seat bottom.

These pieces of  $\frac{3}{8}$  or  $\frac{1}{2}$  inch whitewood, cherry, or soft ash must next be firmly glued together (Fig. 1) without

mitering or nailing, and when thoroughly dry a triangular piece of ash fitted into the corners, as at A, sufficiently thick to sweep the round corner

wanted. When all is dry, the corner is shaped by the aid of a draw-knife, &c., rounding it outside and hollowing it inside. For this last purpose the back-piece may be secured to the

bench by a hand-screw. Much trouble in finishing may be avoided by shaping the different pieces on the inside in the vise, before gluing, taking care to leave the portion where the block fits in undisturbed. Having shaped the side portions of the seat, they are afterwards secured to the bottom frame by screws from the underside, all fitted in their places previous to being shaped.

The following rule (a secret with many coach-makers) for fitting a block in a corner without being compelled to resort to "the cut and try" system, will be useful in this connection. A reference to Fig. 2 will serve to illustrate our subject.

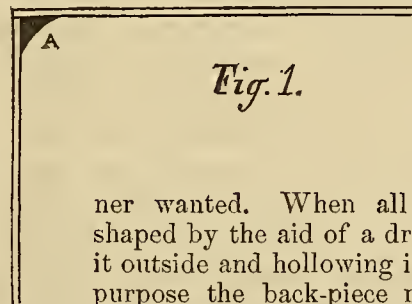
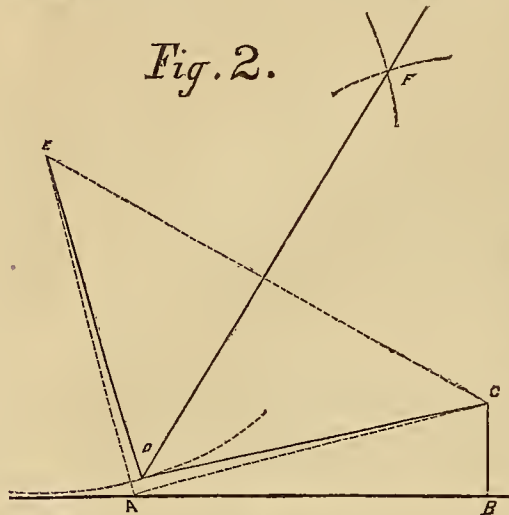

Fig. 1.

Suppose we want to set our bevel square to dress the sides of the corner-block for a seat made on a bevel of four inches to the foot. Draw  $AB = 12$ ,  $BC$  perpendicular to  $AB$  and equal to 4; next draw line  $AC$ ; afterwards draw a line from  $A$  to  $E$ , at right angles to  $AC$  and equal to it. Then from  $E$  and  $C$ , with the distance  $AB$ , describe circles cutting each other in  $D$ , and  $EDC$  will be the angle required. Bisect this angle, and  $CDF$  or  $EDF$  will be the angle for the miter of the boards for the ends of said boards. After a draft is made, the triangle may be transferred to the edge of a board, in order to set the bevel square.



#### REPORT OF CARRIAGES IN THE LONDON INTERNATIONAL EXHIBITION, OF 1862.

OUR London correspondent early favored us with a copy of the Jury's Report on Carriages in the International Exhibition, but too late to be made available in our last issue. From this Report we learn that 140 carriages were on exhibition from different nationalities. These consisted of 24 Phaetons, 23 Landaus (a draft of one is given in this number), 21 Broughams, 13 Sociables, 9 Wagonettes, 9 Sleighs, 7 Barouches, 5 Vans or Wagons, 4 Coaches, 3 Chariots, 3 Four-in-hand Coaches, 3 Private Hansoms, 3 Dog Carts, 2 Public Omnibuses, 2 Carioles, 1 State Coach, 1 Dress Chariot, 1 Droski, 1 Irish Car, 1 Town Car, 1 Gig, 1 Clarence, 1 Basket Carriage, and 1 Cart. Medals to the number of 35 were awarded, of which 23 were given to British exhibitors. We are informed by a private note, that in order to avoid any accusation of partiality, the Committee "made no mention of any exhibition by name, either to praise or condemn, considering the jury as a body responsible for the awards and the reasons appended to them." We approve of this prudence in leaving each exhibitor to judge for himself as to what criticism may apply to his productions. The following extract, which space compels us to divide, will interest the reader:

This is the fourth Exhibition in which British carriage-builders have taken part; in London in 1851; Dublin, in 1853; Paris, in 1855; London again in 1862.

The first Exhibition, from various causes, did not legitimately display the state of British carriage-building at the time; and many manufacturers, from the novelty of the whole affair, seemed to have mistaken its purport, and allowed themselves to run into extravagances of design

and construction, of which they have since seen the ill effects: the impression made on the general public was not on the whole favorable, and the Exhibition itself did little (with a few exceptions), to increase the reputation out of doors of the great body of carriage exhibitors. Nor was the position assigned to the carriages by any means favorable, being in a remote part of the building, to which many of the visitors did not penetrate, and who were consequently unaware of the display. The mode of lighting from the glass roof was, besides, unfortunate for a favorable display, as the brilliancy of the varnish was most effectually subdued, thereby detracting from the appearance of beauty and finish of the carriages. The proximity to the locomotive engines and railway plant, standing on rails, in a gravel road, of course did not improve the show space, as from under the open-boarded enclosure the wind blew clouds of dust over the most delicate silks and varnished surfaces.

At the Dublin Exhibition the carriages were even worse placed, as they were lost to the great proportion of visitors.

In Paris the British carriages were banished to the remotest end of the machinery annex, and only the most enterprising of the visitors reached them, and then probably when fatigued; so that until the present time, British carriage-builders can hardly be said to have obtained a position suitable to show properly their productions.

In the present Exhibition the British carriage department extends almost the entire length of the British picture gallery, immediately under which, in the southeast corner of the building, it is situated. It is by far the best home that British carriages have as yet found for exhibition: the light, being admitted by large and high windows facing the south, if not all that could be desired, both as regards quantity and quality, displays to advantage the brilliancy and high polish of the varnish; although the crimson blinds that exclude the rays of the sun from the south give an attractive appearance to the whole gallery, the effect on the colors of some of the carriages is most prejudicial; it should be a warning in future Exhibitions that a certain tone of color for the fittings of the whole building should not be insisted on with too much rigor. Had it been permitted to stipple the glass, at a trifling expense, the powerful rays of the sun might have been excluded at a small cost, and with more benefit to the exhibitors. Were the floor of the picture gallery a little more impervious to dust, and the wall decorations not quite so coarse, it would be a very near approach to perfection for the purpose intended.

Having thus glanced at the manner adopted for getting the best possible display—the position of carriages at former Exhibitions, and the commodious home afforded them in 1862—a glance at the preliminary report appended to the awards will show the number of exhibitors from each country, and the varieties of carriages that form the entire collection.

As might be naturally expected, the English contributions far outnumber the combined productions from all foreign countries, and those from London outnumber those from the provincial towns. London may indeed be said to be the chief seat of the carriage manufacture, both from the general excellence of the carriages built, as from the extent of the trade. Among the provincial towns, Edinburgh, Dublin, Derby, Bristol, Liverpool, Manchester, Nottingham, Southampton, Glasgow, and Newcastle-

on-Tyne produce largely for the home and export trade. On the continent of Europe, Paris holds the highest place as regards the excellence and the extent of its carriage-building trade, which of late years has much increased, as well as improved in the style, workmanship, and durability of its productions. The French export of carriages has also greatly increased of late years. A large trade is also carried on at Brussels, Hamburg, Vienna, Aix-la-Chapelle, Offenbach, Milan, Rome, the Hague, St. Petersburg, and other cities and towns.

America, which only contributes two very light carriages, has rapidly risen to a great producing country for carriages: its productions are of a type quite original and peculiar to the country; and in some points have attained a singular excellence, as regards lightness combined with comparative durability: their execution shows good ability on the part of the workmen. To Europeans these light carriages have a very singular appearance; they, however, probably meet the wants of the American public from their light draught. The bodies are small; the difficulty of getting into the carriage among or over the high wheels, is one requiring great activity to overcome, and the quantity of mud thrown by the very high wheels must be somewhat alarming.

There exists an Imperial manufactory for carriages at St. Petersburg, directed by an Englishman: it is well organized, and adapted for producing the private carriages used by the Russian Court. The various processes are there carried on, even to the weaving of the lace and the production of the ornamental metal chasings; it has probably had a good effect in improving the carriage manufacture in Russia, the contributions from which country are not only numerous, but show points of careful consideration in the construction and design. The Russian nobility are fond of having their equipages well turned out, and import many carriages from England, France and Germany. The carriages in Russia, and those sent there, must necessarily be strongly built, as the thaw in spring, after the winter frosts, so breaks up the roads and paving, that a light or weak carriage must soon give way. Unlike these must be the carriages for the Australian markets, where, in consequence of the taste for light carriages built on the American system, much of the trade has fallen into the hands of the coach-builders of the United States.

The tastes and requirements for private carriages have evidently of late years taken a great change. The English department does not contain a single carriage fitted with a hammercloth; such carriages are still used by the high aristocracy of England during the London season. There were two excellent examples of town chariots with hammercloths sent to the Exhibition of 1851; and it is to be regretted that such carriages, which are capable of bringing out the best abilities of the constructors, are not to be seen in the department: perhaps for some future Exhibitions, gentlemen of taste, wealth, and rank may feel inclined to give orders for such carriages, that they may be temporarily placed in a collection that is certainly not complete without them.

Nor is there a traveling carriage. We may now perhaps feel assured that the railway has the entire monopoly of transporting travelers on long journeys throughout western Europe; there are still links missing in Spain, Italy, Sweden, Russia, and a few other States of Europe; but as regards the manufacture of private traveling carriages in England, it is now evidently a thing of the past,

probably soon to pass out of mind, or only to be remembered by the older masters and craftsmen.

An important omission may here be mentioned as regards public carriages for the streets of cities and towns. Was London at last really ashamed of its dirty and rickety cabs? As regards its street cabs, London is worse supplied than many European cities (with the exception of a few clean and well turned-out Hansoms), and far worse than most of the English provincial towns. There is no necessity to vary the size and build of such vehicles, as they exist here in only two types: the "Hansom," as an open one; the "four-wheeler," as the close one. They might be produced in great numbers by machinery; all the parts might be duplicates one of another; the wheels, axles, springs, bodies, seats, &c., might all be made of one size and gauge, to interchange; the rapidity of manufacture, facility of repair, and general economy of production would appear to be advantageous to all parties; and those of the public who cannot afford to keep carriages of their own, might be carried in vehicles that should be at least clean, safe, and comfortable; and with a little more care in warehousing they might be brought into use without that very pungent smell of the stable, that is probably disagreeable to every one except the owner and the genuine London cabman. For many years the public omnibuses in Paris have been made on this plan; the various parts are made alike, and to interchange; the facility and rapidity of repair in such cases is more advantageous than may at first sight appear, as every day the vehicle remains idle under repair is a loss to its owner, whose profit depends on its being at work and earning money.

The choice of carriages for display was entirely left to the discretion of each exhibitor, so that it was quite a matter of chance what carriages were represented, and what entirely unrepresented; it would even have been possible that all the carriages on their arrival might have turned out to be broughams when the packing was removed. It may be worth while to consider, in future Exhibitions, whether some plan could not be adopted of showing all or most of the carriages in use at the time; and whether it is necessary to the best possible display that exhibitors should have nearly an equal amount of space allotted to them, whether their productions are first class, second class, or only one remove from third class. The object of these periodical displays is probably to interest and attract British and foreign sight-seers and purchasers, and if possible to leave an impression of their general excellence. It is likely that many of the objects shown will hardly receive a glance from visitors, while others will excite their admiration and desire to become the possessors: the question to be considered would be, whether more benefit would not accrue to the whole trade by a display verging on perfection, rather than by a very mixed display, of the merit of which doubts should exist in the minds of visitors; besides the greater attractiveness of high quality in design and execution, over mere quantity and variety.

The reverse of this plan seems to have been adopted with some success in several departments of manufacture: such as "engineering," "pottery," "jewelry," &c., &c., where the most distinguished manufacturers have such space and positions allotted to them as induce them to make great efforts, and incur great expense to produce a display that attracts much attention, and indirectly ben-

efits the whole trade by the amount of notice drawn to the productions of their class, besides the advantage that is afforded to workmen and manufacturers, by having the best productions of the time freely submitted to their inspection and criticism, and enabling them to make many real improvements.

There seems an increasing desire on the part of British and foreign carriage-builders to show their carriages in a partially finished state. This seems to indicate a straightforward desire of convincing the public that the wood, iron, and workmanship concealed by the painting and lining are as good as they should be to insure durability: although not possessing so attractive an appearance to the general public, many purchasers will not be at all displeased to find they are served with wood and iron of first-rate quality.

Woods are shown in such great quantities and of such excellent quality by many of the English colonies, that it will be strange if the colonists do not open a trade with the coach-builders of Europe. The difficulty of bringing the producers and consumers together seems to be the great hindrance to opening a trade: if they could be brought into contact, either personally or by letter, a direct trade might soon be opened, probably on a small scale at first. From the excellent quality of some of these woods as regards strength, toughness, elasticity, size, &c., they would probably advantageously increase the supply of woods that are serviceable for carriage-building. The list of useful colonial woods for the coach-builder, inserted in the report on the carriages of the Paris Exhibition, seems up to the present time to have remained a dead letter. This is probably owing to the comparatively limited circulation of these Official Reports; were they published separately in the same form, or perhaps with the parts of the Illustrated Catalogue, and sold at a cheap rate, they would have an increased circulation, and fall into the hands of practical men at home and in the colonies, who would carry into practice what can only be referred to slightly in a general Report.

The only new woods recently adopted by the English coach-builders are the Canadian black walnut and American hickory. The former grows to a great size, and is advantageously cut into panels, which are free from figured grain, and for many purposes are an excellent substitute for Honduras mahogany. It must, however, be recollected that it requires time and great care to introduce new woods into a manufacture like that of carriages: they must first be thoroughly seasoned; it must then be ascertained by experiment if they require any peculiarity of treatment, or care in working; then if they are adapted to the variations of our climate, and what effect a hot sun in summer, or a continuance of wet in winter has upon them. The black walnut has been adopted by many of the principal upholsterers and piano-forte manufacturers for their internal fittings. The hickory is a most valuable wood for the spokes of light wheels.

Of all people, the Americans seem to have been most successful in applying machinery for working wood. One of their most successful applications is the making of wheels by machinery. Not only have they an excellent supply of light and tough woods, but the skill they have acquired, especially in making light wheels for carriages, has produced for them a great reputation. A trade has now sprung up in the importation of these light wheels to England for broughams and other light carriages. [The

Editor of this Magazine is constantly supplying such orders.]

A self-acting double-fold step of very ingenious construction is sent from the Duchy of Hesse.

On a brougham sent from Russia is an ingenious double-action spring door-lock, so that the inside and outside door-handles act independently, thus reducing the friction and wearing of the spindles. The same manufacturer shows an excellent "droski," the national carriage of Russia. As such vehicles are the most numerous and the most popular in Russia, this one deserves notice, especially as its construction is so totally different to any English carriage. The mode of attaching the shafts to the horse and of harnessing him, merit inspection, as it is said that horses harnessed on the Russian plan rarely fall—in fact, are much supported by the way they are put to their work. The lightness and strength of the Russian harnesses particularly merit attention, the leather part being so light as to appear unsafe to English eyes. This, however, is due to their peculiarly prepared harness leather, which is marvelously strong. As the Russians are almost as great in their way at driving, as the English in theirs, their harness and methods of attaching horses to their work are worth attention.

Many and very considerable changes have taken place in the manufacture of carriages since 1851, mainly in consequence of a smaller breed of horses being used, so that a demand has arisen for smaller and lighter carriages. In point of weight there is a remarkable difference in the carriages of this Exhibition and that of 1851: it is probable that there is an average diminution of about one-fourth in the weight of all the carriages shown in the British department. Added to this, manufacturers have endeavored to combine greater elegance of general design with reduction of weight; under this head several manufacturers have combined the attributes of comfort, lightness, and elegance with great success.

In the combination of colors, the British department has also shown progress, many of the carriages being both painted and lined in excellent taste; the selection of colors showing attention to a point on which much of the appearance of a good equipage depends. As the best design, workmanship, and material may be entirely neutralized in appearance by a bad selection of colors, this is a point that can hardly be too strongly insisted on: there are, however, a few rather glaring departures from the general care shown on this point. Not less so is the still prevalent practice with some coach-builders, of overloading with superfluous ornaments carriages which from their construction are evidently intended for ordinary every-day use.

Another improvement very recent among the British coach-builders is the use of tough steel instead of iron for carriages that are required to be built very light. This material might perhaps be more accurately described as a very dense, hard, and tough iron, that is capable of welding, but requires somewhat more care than ordinary best carriage iron to work, than which it is about three-eighths stronger, giving a considerable diminution in weight when used throughout a carriage. It is also applicable for coach screws, nails, bolts, and clips. They have this advantage, that, being of equal strength, with less bulk, the holes necessary to be made in plates or stays need not be so large; as although holes are absolutely necessary to attach them, the smaller they can be made, the less they weaken the object they are made in.

The manufacture of fancy wood panels, imitating interlaced basket-work, is now established in England. This very ingenious invention is due to France, where it was first made by a retired soldier of the Empire, named Fert, who not only made large quantities for the French coach-builders, but for some time exported a considerable quantity to this country. By improved machinery it is now made in England more accurately, and in a greater variety of patterns than in France. It is much used to give a light appearance to small carriages, principally for country use. It forms a neat and durable substitute for the real wicker-work formerly used, which rapidly becomes deteriorated by mud and moisture.

(To be concluded in our next.)

## Home Circle.

### A TALE FOR THE TIMES.

BY GEORGIANA E. WATSON.

My grandmother believed in dreams, and many a time have I listened to her relation of very wonderful ones, especial revelations to herself or some of her friends. They were not dreams that really came to pass, nor did they "go by contraries," but generally bore some mysterious relation to the present or the future, and were quite as capable of a double construction as the answers of the Delphian oracle. Strange as it may seem, my childish love of the marvelous, albeit it led me to listen with eagerness to their recital, never gave me any faith in their fulfillment, though the good old lady never failed to confirm her own assertions by a reference to a certain venerable prelate, who, *she says*, affirmed "that *there were some dreams* that had warnings in them." With this belief in dreams was mingled, too, not a little of faith in ghosts and spirits, witches, and contracts possible to be made with a certain gentleman whose family name may not be mentioned to ears polite.

But I was skeptical, wondrously so. I loved dream-land, and spirits, and fairies, without a fear. I can remember that I often wished to go to sleep and dream my childish fancies over again; and in my love of spirits, mysteries and dreams, if I have grown older I have grown no wiser. I love them yet. But with my quiet life among romantic scenes in the country, and my dreamy student life among books, where I sometimes can hardly tell whether I belong to the mighty past or the busy present, has come the feeling, that

"Hands of *invisible spirits* sweep the strings  
Of that mysterious instrument, the soul—  
And play the prelude to our fate."

But *visible spirits*, knockings and the like never reach my faith, though, if you will not laugh, but read on, you may think that, "if seeing be believing," I ought to be credulous.

One day, strolling into the churchyard at T——, where for many years, in the quaint words of my favorite author, "the spire of the church has marked the passing time on a dial, the hours and minutes of which are the graves of men," I thought that if any spot should have its presiding ghost it is this; and though I believe the good people are too sensible to fear what to them is a hallowed "God's

here," it is quite certain that the bridge just below was the scene of Ichabod Crane's adventure with the "headless horseman," while on that knoll just beyond the boundary fence are the remains of a slight fortification used during the Revolution. It was to this spot I went, on an Indian-summer day, when the "silent ministry of the frost" had flung a robe of many colors over the woods, and the purple aster and the golden rod mingled with the many-tinted leaves to form a gorgeous coronal for the dying year.

Sitting down upon a strange, flat stone, I thought of the sleepers around me; how quietly they were lying there—of the two pastors resting among their flocks—of the little children, and the old people, who had been borne amid tears day by day to their graves, and how many were there whose resting-place was unmarked by stone or tablet. Thus I mused away the time, when directly I saw a figure approaching me; but it was broad daylight, so I supposed—though I did not see him—that the intruder had climbed the fence, as I did the day before, where the rails were off. When he came nearer, I saw that he wore the dress of the olden times—small-clothes, a queer coat, and a Rip-Van-Winkleish-looking hat; but there was a very human look about his face, and when he spoke his smile was as bright as the surface of a Dutch pewter-platter.

"You choose a strange place to visit," said he, as I bowed at his approach; "these are rather silent companions around you."

There seemed nothing unearthly in the tones, and I answered: "They are silent, but I am selfish and like to do all the talking myself, so they are more agreeable than the living."

"Well, well," said he, "every one to his taste; for my part I prefer the living; yet times are changed, and one who liked the ways of eighty years ago, will not be very well suited *now*—and might almost as well be lying here."

I looked at him—eighty years ago! thought I, and he evidently saw my surprise; for he smiled a broad smile. "If you can remember those days," said I, "you must have strange stories to tell of them;" then came the smile again. "Yes, but people now-a-days are too busy to listen to them," he replied; "I could tell you of many that are here; of the farmers and their *fraus*, who used to come to the church on Sundays; stout dames were they, who could spin and make butter and cheese and take care of their children, while the men quietly smoked their pipes, and talked over the affairs of the church and the Governor's doings, or of the grave-wise subjects that the Domine and Schoolmaster discussed of when they met." I saw that my visitor was delighted with my attention, and I did not attempt to interrupt him; but I must give you his story more briefly than I heard it.

"Do you see that stone," said he, pointing to one a little way off. I nodded my head, for the grave-yard looked strangely. There appeared fewer graves than when he began to speak; but I looked and he went on—"that is Dame Von Scaick's; the name is almost obliterated now; but she was once the most notable woman in all Sleepy Hollow; she would have the floors of her house scrubbed every day, and no carpets on them—for she said they were fit only for people too lazy to use a mop—and the yard and the barn were clean, you may be certain, and even the pigs were scrubbed once a week!

When she died the Domine said that 'she did not only keep clean the outside of cup and platter'—they were always so bright you could see your face in them—'but, that she took care of the *inside* too.' Poor Herr Von Scaick lamented her dreadfully, and had a mop and broom cut upon the stone, for, he said, she always had them in her hands, and these would remind him of her quicker than anything else.

"Yonder broad stone," he continued, "is all that now tells of Frau Van Vampt, who was the only woman in all the country round that ever seemed to think she was as wise as her husband. The gossips said it was a lucky day for Hans Van Vampt when he married the only daughter of old Rödwig, for none had such stores of linen and woolen as she—and the farm was hers too, for there were no sons—but the wiser ones shook their heads, and said that Hans would find his hands full with his wife. But the wedding was a grand thing, and people would not listen to what the young men said, for 'it was nothing but envy of Van Vampt's good luck.'

"Hans had always been a merry fellow. He wore the gayest of blue coats and brightest of brass buttons—his hat was never straight on his head, but put upon one side, and none were more ready to smoke a pipe with a friend, or enjoy a joke, than he. For awhile it continued so—the laugh was just as ready and the twinkle of his eye told quite as often of the fun that was coming—but, by-and-by, there was a change came over him; he began to sigh sometimes, and in a year (a surprisingly short time to the good folks then, for, when they were married, they sat down to be happy and contented for the rest of their days)—in about a year—Hans grew very sober and did not take the jests of his friends as good-humoredly as of old—his hat was no longer put on with such a care-for-nobody air as formerly, but oftener hung over his eyes, and soon he was the topic of general gossip among the women, who wondered what was the matter with Hans, for once he was the life of the village, but now his last practical joke had been long forgotten.

"The truth was—and the guesses of the good dames were about right—that his wife was too much for him. Hans was not the most prudent fellow in the world; but he could not bear to be told of it; and she was constantly scolding him that this or that was not done, or done very differently from what *she* would have it. He bore it for awhile, but it made him sullen, so that he would sit and smoke his pipe without saying a word for hours. One day he came home from market where he had been rallied on his dullness, and the frau scolded him for having staid so long. 'Dunder und blitzen,' broke forth Hans; 'make your cheese and work your farm; I will go to Niew Netherlands directly, and then we will see who will call Hans Van Vampt a fool.' So out of the house he went, and straight down to the sloop that once a month came from Niew Netherlands to Albany and stopped along the river to bring tobacco for the men, and trinkets for the youths and maidens.

"Now Frau Van Vampt's troubles began; she could not believe at first that Hans had really gone, for she never meant he should go; but, finding he did not come home, she made up her mind to show her spirit, and went to work; and sad work she made of it, for while she was gathering apples, the curds and cream were spoiled, and when she went to the barn, young Hans, who was creeping about the kitchen, threw over the bench and raised

a new lump on his skull. Then she took it into her head that the home was haunted, for—(and here I saw him smile)—the men pitied Hans and managed to do strange things about the house and barn."

Just as this sentence closed, I heard the whistle of the steam engine, and turned my head to see how high the sun was. When I looked again, my friend was gone—where, I could not tell—only I saw a strange motion among the grass over one of the mounds near me. I arose and walked home, wondering what would have been the conclusion of the tale; or whether it would have had any, and thinking what the defenders of woman's rights would say to it, and whether they would admire the spirit of Frau Van Vampt. When I told my adventures at home, some laughed and said I had been dreaming; others declared it "was only one of Lizzie's fabrications;" but sister Susie whispered, "you have been talking to a *ghost*!"

I shall not say what it was, but if I ever see my old friend again I will get the remainder of the story and tell you what became of Hans and his Frau, who, I suspect, was in the end very sorry for having thought herself so wise, and glad to send for her husband to take care of the farm—and her, too.

## Pen Illustrations of the Drafts.

ENGLISH LANDAU.

*Illustrated on Plate I.*

THE original from which our drawing is taken, although, as we are informed, not expressly made for exhibition, was a contribution to the late International Exhibition from Messrs. Whittingham & Wilkin, dealers in carriage-builders' materials, 136 Long acre, London, and is a very fair sample of the English style of the Landau, very popular in that country the past season. The body (a little too deep for our latitude) is painted in imitation of eanework, to show off which was one object in exhibiting the vehicle. Whatever criticism we may exercise as Americans, it must be conceded that this Landau is built with graceful and easy-flowing outlines, flat falling heads, and a general exercise of artistic taste which challenges our admiration. We notice that the builder of this vehicle has adopted our combination spring, published eighteen months ago in this work, on page 10, Volume IV. As a family carriage for summer or winter use, in our judgment, none equals the Landau; and yet they have never been popular in this country.

GIG WAGONETTE.

*Illustrated on Plate II.*

THROUGH the courtesy of Messrs. Brewster & Baldwin, of Broadway, New York, we are enabled to present our readers with this beautiful draft of a combined gig and sociable. This kind of vehicle is found particularly useful for boarding-schools and watering places. They

are certainly calculated to promote sociality, as, omnibus fashion, the passengers are seated face to face.

In building, the gig portion may be made from white wood plank, two inches in thickness, with the swell and mouldings worked on; or, with increased labor, the same may be framed and paneled as in the old mode. This portion is afterwards secured to the bottom-side, this last being made in such form as to shape the back portion of the vehicle. The square portion of the back-quarter, representing French basket-work, should be sunk into the panel, or else painted in imitation of it. The general construction of the carriage is so very simple that further detail may with reason be dispensed with.

#### LIGHT BUGGY.

*Illustrated on Plate III.*

SOME persons seem to think that so apparently insignificant a vehicle as a buggy requires but little exercise of talent to insure elegance. We assure all such that they are very much mistaken. To design a really handsome buggy requires taste of the highest order, and such we pronounce the taste which produced our draft. Although simple, a buggy made with good judgment after this model produces a salable article. We know from experience. The side piece for the body together with the moulding at the bottom are both worked out from solid ash 2 x 2 inches, and afterwards secured to the frame of the body in the usual way. The details are so well expressed in the drawing that any further remarks would be superfluous.

### Sparks from the Anvil.

#### IRON CHECK-LOOP.

THIS sectional diagram is drawn to exhibit the under side of a buggy, and show the position of an iron check-loop, intended to prevent the breaking of the bolts that

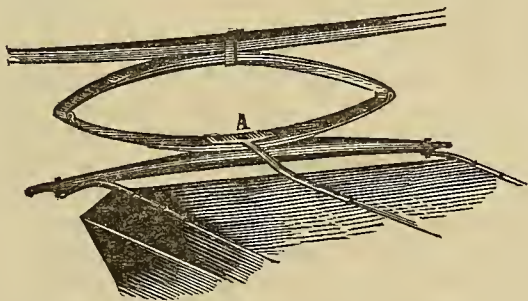

secure the body-loops to the spring-bar when the vehicle is in use and falls into ruts. The check-loop is made in the form of the letter T, the top

taking the two bolts securing the spring-bar to the spring at A, and the lower end of the T taking two bolts through the floor of the body. The effect of this simple contrivance is to break the force of the upward strain imparted to the body-loops from concussions in passing over bad roads, whereby the hanging-off bolts are often broken at the head, if not subjecting the passenger to danger, yet exposing his vehicle to great damage. This loop we have found by experience to be an effectual remedy for the

purpose intended, and worthy of trial by our friends. Try it for yourselves, and see if we are not correct.

#### ANOTHER ANTI-RATTLING FIFTH-WHEEL.

ON page 191 of our Fourth Volume, we presented the reader with a diagram of an improved fifth-wheel, so contrived as to prevent any difficulty complained of from the rattle common in that part of a buggy. The present is a different remedy for the same purpose, which we will endeavor to describe.

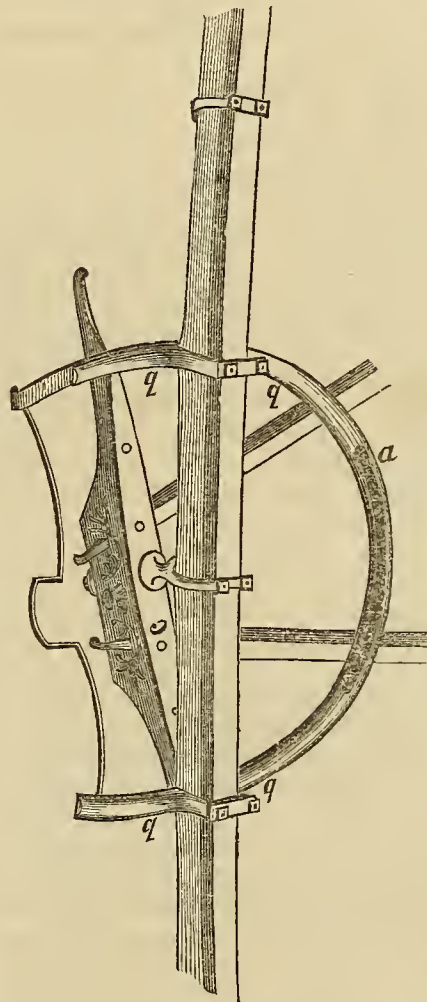

The letters *q q q q*, represent the under half of the fifth-wheel, forged with a solid clip, by which it is secured to the axle in the usual way. In this lower or under half of the fifth-wheel, indicated by the dark line extending down from *a*, a circular slot is cut, to allow a bolt to play when the vehicle is locked—technically, *cramped*. This bolt—more properly, *pin*—is forged T-fashion, solid in the top circle-plate, and extending through the slot in the under-plate, receives a nut on the under side, between which nut and the circle-plate a small, circular piece of india-rubber is placed. The effect of the arrangement is to prevent

the usual clatter consequent on using two parallel plates, by confining them together, the rubber acting as a spring to confine them when going over smooth roads, and yet permitting play enough for separation when passing over rough places, or falling into ruts. This fifth-wheel, like the former one, is untrammelled by any patent, and free for the use of all. It is frequently adopted for the finest made New York buggies.

#### BESSMER'S IMPROVED STEEL.

BESSMER, whose experiments in making steel six years ago attracted much notice, it appears from our foreign files, has completed a revolution in the manufacture, cheapening the article and improving its qualities. Specimens have been bent and twisted cold, showing it to possess ductility in a remarkable degree, and it is even more plastic and manageable than copper. Samples have been submitted to the tests of bending and twisting in both the hot and cold states, without previous annealing, with the most satisfactory results. A plate of 18 inches diameter

has been forced through a series of dies until it formed a tube 13 feet long and  $1\frac{3}{4}$  inches diameter, without producing either a fracture or flaw. In drilling holes through a plate continuous shavings are formed by the drill; whereas, in the same process with copper and Low Moor plates, and most other metals, the shavings are not more than  $\frac{1}{16}$ th of an inch long. Thin sheets of this soft steel may be bent backwards and forwards many times without breaking, and are said to be nearly as malleable as paper.

## Paint Room.

### ABOUT SPONGES.

EVERY painter understands the value of the sponge in cleaning the surface of his work; but probably very few are acquainted with its history. The fine kinds of sponges come from Turkey, and are sold at the apothecary shops. This country is chiefly supplied from Barbadoes, The Bahamas, Key West in Florida, and Nassau, New Providence, this latter place now famous as the starting point of the English merchants engaged in supplying the rebels with contraband goods—a species of *sponging* our European friends have not as yet found very profitable. The coarse kinds of sponge, such as are in common use among painters and other branches of mechanics, are brought from the Bahamas. All sponges, except those included in the genus *spongillia*, are marine, differing very much in their habits, some growing at greater depths than others, the finer ones (those from Turkey) being found in water thirty fathoms deep.

Sponges belong to the lowest class of animals, the skeleton of the living sponge being clothed with a fibrous net work, strengthened by spicules of mineral matter, and covered with a soft, fleshy substance. In the *spongia officinalis*, or ordinary sponge, the skeleton is almost entirely destitute of spicules (sharp points like a dart), but the curious and beautiful Barbadoes sponge has its entire network composed of silex almost as transparent as glass. Sponges attach themselves to rocks and shells at the bottom of the sea, and are obtained by the divers and detached from their fastening with a two-pronged fork fixed in a handle. When the sponge is taken from its bed, it is placed in a crawl for cleaning. This crawl is constructed of stakes about two inches thick, driven into the mud, forming a square of twelve feet, high enough to prevent their washing out. Here the sponge is soaked and washed frequently, after having been buried in the sand eight or ten days, when it loses the animal matter so offensive to the smell, and is then fit for commercial purposes. There are four kinds of sponges—the yellow, glove, velvet and moss. The yellow is of the most value; the glove, which is the toughest, being on account of its softness most fitted for our purposes. The real value of this article may never be estimated until we are wholly deprived of its use, and are left without an article to supply its place, so prone is man to underrate “little things.”

### DISHONEST VARNISH DEALERS.

MR. EDITOR: *Dear Sir*—Some time ago I sent you a communication exposing the improper and unlawful practices of some parties in the varnish trade (see page 213,

Vol. III.), with some instructions to our mechanics how to treat the actions, and threats of those practicing them. I have since discovered another mode of deception I did not then understand, although perhaps my ignorance of matters so directly connected with my business ought not to be excused. After emptying the casks of the dishonest traders I then exposed, it turns out in many instances their casks do not hold within twenty per cent. the amount charged for. Now I would inform all such mechanics as read this what I did not know myself until recently. Probably many of them know it already; but it may be new to some, and if I can put any one on his guard, I shall be satisfied.

The contents of each cask ought to be found marked on the head thereof, by the gauger, by figures *cut into* the wood; but these dishonest fellows, which I have shown up, are in the habit of *stenciling* the measure on the heads of their casks. This may in almost every instance be counted as an untrue indication of the contents. Always look for the *gauger's mark* as your safe guide.

Yours,

BADGER.

### ORNAMENTAL DESIGNS.

*Illustrated on Plate IV.*

THESE designs are all of the garter character, with fillings-in of our own adaptation, and of the kind now used in New York for buggy panels. Our patrons can vary these fillings-in to satisfy their own fancies, and thereby produce ornaments in great numbers. We shall in coloring leave the artist to exercise his own judgment, and dismiss the subject with a few general remarks. It is customary, in the first place, to lay gold leaf over the entire figure, afterwards shading the central portion of the garter with blue, red, yellow, &c., leaving the edges in gold. The chain, diamonds, spots, &c., may be added with red, yellow and black paint; exercising such ingenuity as the laws of contrast with the surrounding colors would seem to require. A judicious use of colors will produce very pretty figures as simple ornaments for American sovereigns.

## Trimming Room.

### IMPROVED MODE OF LINING BUGGIES.

RECENTLY great improvements have been adopted in the mode of trimming New York-made buggies which imparts to them a taste and neatness never reached by the common display of gew-gaw ornament adopted in some localities. We do not say this with any design of reflecting upon the style of country-made work (for, from personal experience, we have found it our interest to study the tastes of the public, which is our purchaser); but, because the fact is so patent to the minds of all lovers of correct judgment as to stand undisputable. Under these impressions we present our readers with a sectional view of the interior linings of a buggy drawn from one of actual manufacture, premising that our artist has purposely *left out* one of the cushions, for the purpose of showing the iron-work adopted in attaching a shifting rail to a round-cornered seat. This seat is or should be as carefully painted on the in as the outer side, doing away entirely with the necessity of lining it.



The first thing which strikes the eye of the mechanical observer will be the absence of the sun-curtain, so long in

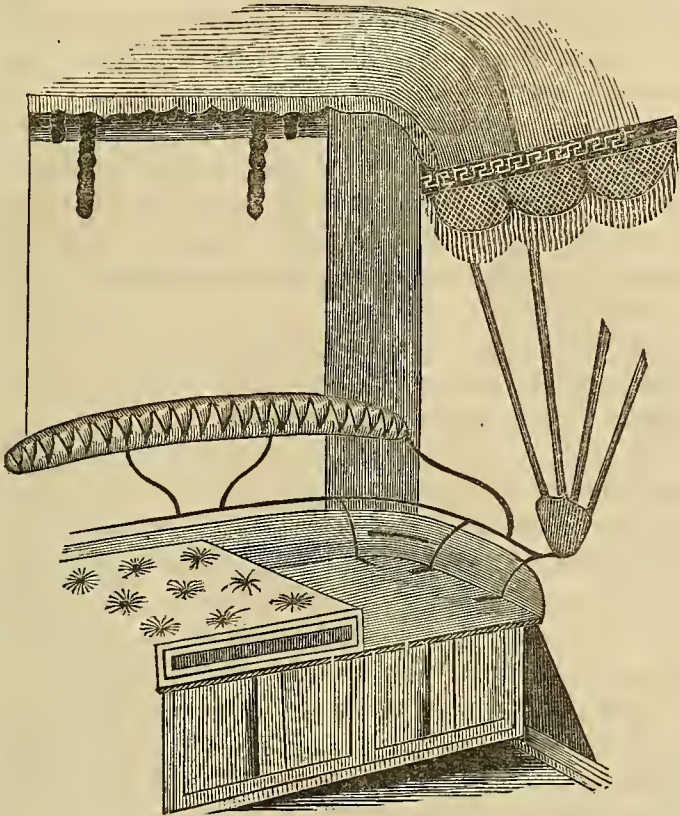

vogue and so difficult to keep clean; and instead thereof appears the beautiful festoon-fringe at the side, and a fancy formed valance for the back; this last being made of leather, and covered with cloth to match the head-lining, and stitched at the edge. Along the side, above the fringe, is placed, as a substitute for broad-lace or the more recent leather belt, one formed of buckram, leather and cloth, in combination. To make this belt take two strips of buckram, about  $1\frac{3}{4}$  inches in width, and around these paste cloth to match the head-lining, and afterwards bind the edges with strips of patent leather. The belt may be further ornamented by stitching, as in our example, or left plain, as fancy dictates. The festoon-fringe has become an article of commerce, and may be purchased of the dealers for about \$2 the piece.

The trimming of our lazy-back is also something new. In this example, before the cloth is nailed on to the frame, it is lined and laid-off in diamonds. Then it is secured to the board by nails at the points, and after stuffing is tacked at the edges—the top edge to the top of the board plain, and the bottom edge sewed to a valance. On the top edge of the back, we next nail two parallel strips of leather, answering for seaming lace, between which two strips we blind-nail a strip of split rattan, to hide the seams. This rattan we cover with cloth, in some instances plain; in others we wrap it with chord after the manner of the seat-rail in Volume I., on page 172, and afterwards cover this with leather.

The cushions and falls also deserve notice. The cushion fronts are made of either cloth or leather, it being understood that the cushions are of cloth. The raised squares in the fronts are obtained by inserting twine, and in our drawing are shown by black lines. The falls are more complicated and deserve a minute description. About one-third the distance from the ends are seen two

plaits made by folding the cloth. Near the two ends, down the middle and along the bottom, dark lines are seen representing strips of chorded leather. On each side of these chorded strips appear other strips about  $\frac{3}{4}$  of an inch wide. These are covered strips of buckram, covered with cloth, and afterwards sewed to the fall. This work is all done by the stitching machine; to do it by hand alone is simply absurd. The roll-stick, as may be seen, is in keeping with the finish, as described for the top of the lazy-back; that is, a round stick is wound with a small chord in a spiral form, and afterwards covered with patent leather. A more particular description might be given; but the practical trimmer, with the common amount of brain, will easily be able to supply the remaining details, especially when furnished, as in this case, with an admirable drawing of the thing described.

Before closing we would remark that instead of using under oil-cloth carpets, it is usual to paint the bottoms of the floor. We need not tell our readers why this is done. The rotten oil-cloths, made so in the frequent washing a buggy undergoes, at the hands of livery stable employees, will suggest the propriety of this course. A fine tapestry carpet, neatly knobbed so as to be readily detached, will supply all the carpet needed for a buggy. This should be removed while the buggy is being cleaned.

#### WAS IT WELL?

BY LUA DELINN.

"He doeth all things well."

BUT was *that* well? Ah! *was* it well?  
 You bid me "Bow humbly, and be content,  
 That the Father should take what His love had lent."  
 Say, "He *ordered* it thus in love." Ah, no!  
 He but *permitted* the fearful blow.  
 But why permit *such* a blow to fall?  
 If he love us, why let us be grieved at all?  
 'Tis only kindness can *win* the heart,  
 And love compelled is of love no part.  
 You say, "When the good pass through death's dark door,  
 Of the 'shining ones' there are all the more."  
 The more *in heaven*, 'tis true; but tell,  
 Are they needed not on earth as well?  
 Oh! was it either *wise* or *well*?

Never heart more loving in woman's breast;  
 Never cooler head bore a warrior's crest;  
 And his lofty brow was as childhood's fair,  
 And frank—all his soul seemed written there.  
 A proud, brave spirit, yet gentle and true,  
 Looked ever forth from his eye of blue.  
 Should he strike in wrath, not the strong might stand,  
 Yet he led the weak with a gentle hand.  
*God-fearing*, but of naught else afraid,  
 And *loving God*, loved all that He had made.  
 The type of all that is good and true!  
 In the wide world his *peers* were few.  
 The *many live*, but there's one the less  
 Of the pure and good the earth to bless;  
 And yet you would tell me that I rebel,  
 And chide when I ask, was it *wise* or *well*?  
 And still I ask, *was* it *kind* or *well*?

But the question comes, "Shall the thing of dust  
 Than its Maker be more wise or just?  
 Shall a weak mortal dare defy  
 Or chide the God of earth and sky?  
 Or even doubt the love of Him  
 Whose watchful eye is never dim?"

I ask no more, Was it wise or well  
 (Though perchance my heart may yet rebel)?  
 No more I question if 'twas kind,  
 But close my eyes (for faith is blind),  
 And say, although I may not feel,  
 "In love He smote; His love will heal;  
 'He doeth all things well!'"

### Editor's Work-bench.

#### TO OUR FRIENDS.

THE unparalleled advance in the price of printing and paper—the last from 13 to 25 cents per pound—in consequence of the war, has compelled our cotemporaries to increase the price of their several publications, or else stop altogether. Our own publication is affected in the same way. To meet the increased expenses, \$5 would scarcely pay; but we intend to compromise with our friends, and have fixed the prices—to take effect after February 1st—at 4 dollars for single subscriptions; 7 dollars and 50 cents for 2 copies, and 11 dollars for 3 copies; Canada subscribers to add to each copy 12 cents to prepay the United States postage, required by the law. Unlike our cotemporaries, we intend to sell our old volumes at the old prices, in the hope that our friends will take advantage of these low rates and send for them at once.

The Fourth Volume, just closed, embraces the period extending from June, 1860, to November, 1861—eighteen months. The present volume will be issued in a similar way—for January, March, May, July, September, November, December, 1863, and for January, February, March, April and May, 1864, bringing the commencement of volumes around to June again, in 1864, when, we trust, war will be ended, and the prosperity of business once more established. At our present rates we shall lose money by publishing, unless the friends of the Magazine volunteer their aid in increasing its circulation. With no expectation of realizing any profit or reward from our own labors, in publishing the Fifth Volume, other than the consciousness of having satisfied our friends and discharged a duty we owe to a generous public, we leave the matter in the hands of the craft, hoping they will not forget *their organ* in this hour of trial.

#### PROPOSED COACH-MAKER'S PROTECTIVE ASSOCIATION.

AN annoying system of espionage has within a few years been practiced in this city and some districts of the country, rendering it extremely hazardous for the coach-maker to pursue his regular business. If he does not institute an inquiry before he commences building a carriage, to ascertain what is patented and what is not, he is very likely to be visited soon after by some contemptible vagabond, too lazy to obtain an honest living by labor,

and yet possessed of sufficient art to rob a man by law, threatening all kinds of trouble, should the poor mechanic not put his hand deep into his pocket and "shell-out" on the instant. If the threatened individual is in the least degree troubled with nervousness, the patent leech is very likely to succeed in "lining his own pocket" on his first attack. In any event, a second visit to the terrified man is very likely to *squeeze* something out of him as a punishment for having infringed upon the pretended patent right of Mr. John Stickensure, or some other person *equally as ingenious*. Perhaps the distressed party had only a few days previously been *robbed* by some other harpy of the same grade, and now this repeated annoyance has a tendency to discourage him altogether.

To provide a remedy against all future piracies from these itinerant robbers, we suggest that the members of the trade immediately interested forthwith call a meeting for the purpose of organizing a Coach-makers' Protective Association, the base of whose operations shall be in New York City. To this Association might be added the names of such members from the rural districts as are willing to join it, and pay in the fees—say \$10 for each member or firm. The fees, as paid in, should be used for creating a fund, and deposited in some safe Savings Institution, where interest would be accumulating, and be devoted to a specific purpose—the legal defence of the members of the Association against all shameless imposters and humbug patentees.

An Association of the nature proposed would very soon relieve the craft from annoyances of the kind noticed above, as the lank pockets and poor prospect of success, on the part of our enemies, would cause them to pause before resorting to the law against the full purse of a combination of interested defenders, every individual of which would be armed with ample testimony for a successful result. An Association of this kind would relieve the mind of the nervous individual, by assuring him that, having paid his money, the Society of which he is a member "is bound to see him through," and supply a large share of comfort to the more brave.

The importance of such an Association as the one now proposed can scarcely be estimated. A moment's reflection will show that a committee appointed by such an association could be formed, whose business it would be to examine into the validity of patents, and when found "all right," so report it. Of course, no honest mechanic would be inclined, under such circumstances, to infringe upon the rights of others, the object of the Association being merely to protect its members against frauds. There are many reasons for the organization of "A Coach-makers' Protective Association," of the kind we have briefly sketched, but which space will not allow of our enlarging upon this month. Meanwhile we trust our readers will give this subject their serious attention, and

duly act before they find themselves hedged in so effectually that they must either stand still and be fleeced or else turn their attention to some more safe way of obtaining an honest livelihood than carriage-making.

#### FOREIGN IMPROVEMENT IN CARRIAGES.

UNDER this heading our readers will be furnished, from time to time, with descriptive notices of all the improvements made in carriages in Europe, as far as we can collect them from our foreign files. In doing this we have two objects in view. One is to give the craft a reflex of what is doing across the Atlantic for their improvement; the other is to furnish them with such facts in regard to patents as will serve to check the frauds unprincipled men in this country are practicing upon the community, in affirming that they are the original inventors of a patent, where, when the truth is discovered, they are found to be merely thieving *geniuses*; in fact, swindlers of the worst character, getting their living under a system of false pretenses.

**METAL CARRIAGE-BODIES.**—From the *Artizan*, we learn that the Messrs. Pickins, of Birmingham, have just specified a patent metal carriage-body, with the object in view of combining strength with lightness. They take a rod of metal, and bend it into the required shape for the seat, and weld or otherwise join it at the ends; then a second bar or rod is bent into the form for the back of the body, and its ends joined to the seat-bar or rod. Transverse wires or rods are afterwards fastened across the seat-frame, and one or more fastened midway of the back frame. The skeleton-frame thus formed is completed by adding a number of crossed wires of an ornamental configuration, following the sweep of the back and decorated with woven wirework and wire scroll. It is recommended that the whole should be galvanized. Our readers will do well to study, in connection with the foregoing, an article entitled "Iron Carriage-wheels," on page 177 of our Fourth Volume.

**OPENING AND SHUTTING THE HEADS (TOPS) OF CARRIAGES.**—C. H. & E. Morgen, in England, have patented an apparatus for the above purpose, by which the head is opened and closed at the will of the coachman, by pressure on a lever as he sits upon his seat.

**IMPROVEMENT IN C-SPRINGS, WHEN USED WITHOUT A PERCH.**—J. Dodge, the inventor, tells us that his object is to insure the axles of carriages in which C-springs are used without a perch, being retained in their proper position, and thereby prevent the irregular running or "wabbling" of the wheels. To accomplish this, he applies two parallel rods, by means of a clip on the axle, and through a brace or braces to the free end of the C-spring; the opposite ends of the parallel rods may be attached to the body of the carriage, or otherwise.

**SELF-WEIGHING CART.**—A self-weighing cart, designated the "Voiture-basculé," has been patented in France and England by Messrs. Debruil & Co. This invention enables the owner to weigh his load without removing it from his cart, at any place where it is received or to be delivered. The Voiture-basculé is merely a combination of the ordinary cart and steelyard weighing-machine, so arranged as to be as firm as any ordinary cart; consisting of a strong frame mounted on wheels in the usual manner, the body being made entirely separate. The steelyard is fixed in the center of one side of the frame, the short arm being connected by a rod with the end of a lever passing in the same direction as the axle, the opposite of which is keyed to the fulcrum, which is attached to the other side of the frame. Between this fulcrum and the rod attached to the steelyard there is a saddle, connected with the apexes of two triangles, the bases of which are at each end of the frame, and are supported on knife-edges of hardened steel. While this cart is in ordinary use, the body is bolted to the frame, independent of the weighing machine; but, to weigh, these bolts are removed, and four screws turned, elevating the knife-edges, and carrying the bases of the triangle about half an inch. Now, as this elevation causes the cart-body to be lifted upon other knife-edges upon the upper side (also at the bases) of the triangle, it follows that the weight of the cart will be thrown on the short arm of the steelyard, when the load may be weighed in the usual manner. The operation of weighing occupies about ten minutes.

#### OUR PRESENT NUMBER.

IN issuing this new volume we have thought it to be an improvement to omit the *newspaperish* introduction to each original article, so frequently repeated in our previous issues, and follow the custom of our cotemporaries,—it being understood that where not credited, such *is* original. With one exception the present number is entirely filled with matter never before published. To secure our property against piracy, we shall copyright all cuts and matter published in this Magazine hereafter. This, while it serves to protect us against dishonesty in other publishers, is not designed, as some of our friends have supposed, to stop them from using the plates as working models; but to prevent their being transferred to the block and re-engraved for use as advertising cuts, or in getting out business charts and pamphlets. If any of them are wanted for such purposes, we are open for a liberal trade, and will furnish them cheaper than any one else can do it; but we intend to stop this helping one's self to cuts where we alone have the legal disposal of them, as has many times been done since we originated this periodical. This, every reasonable person will admit, is no more than fair, and that those who transgress ought to suffer for their dishonesty.

## EDITORIAL CHIPS AND SHAVINGS.

WAGON-MAKERS AND BLACKSMITHS IN DIXIE.—The rebel Congress has passed an act exempting from military duty editors, employees of telegraph and transportation companies, ministers of the Gospel, physicians, shoemakers, tanners, blacksmiths, wagon-makers, millers, overseers of plantations, superintendents and employees on government works, and one man to every 500 head of cattle. We are at a loss to tell why the craft South are thus favored, unless it be that they may find time to build ambulances and hearses. These will, without doubt, all be in demand before the war ends. As for the editors, they are not worth much with the musket, and are a worthless set any way—in the minds of some people.

INCOME DUTY ON CARRIAGES.—A committee of carriage-makers having waited upon Secretary Boutwell, at Washington, in relation to the unreasonable tax laid upon carriage-manufacturers, they received for answer that "he would liberally construe the law, so as to favor the trade as far as he possibly could." This *liberal construction* has since appeared in an answer directed to Messrs. Brewster & Co., of this city, in which he declares that there will be no tax on jobbing, but that on new work we must pay three per cent. on the amount of all sales when made. As springs, axles, &c., to nearly one half the amount of sales, have been previously paid by manufacturers, the duty actually paid by us is equal to a tax of  $6\frac{1}{2}$  per cent. What effect this unjust taxation may produce on the business remains to be seen, but our fears are of a most serious nature in regard to the matter, and we think the subject calls for special legislation by Congress this session, before the trade is ruined, as was the case in England at the close of the eighteenth century. An examination will show (see on page 160, Volume Four) that we are taxed higher than were our ancestors, half of whom were driven into other branches of business for a livelihood. Superior enterprise of a national character may in some way overcome the difficulty, but the tax will undoubtedly retard the progress of trade among us.

SCIENTIFIC STUPIDITY.—A short time since a country carriage-maker sent a communication to a scientific cotemporary, "asking for information upon the subject of setting wagon wheels so as to make them run easily on their axles, the questioner supposing that much depends upon the *dish* of the wheel. Instead of properly answering the question, as knowledge would have dictated, the "scientific" man runs into the egregious folly of recommending "ball axles" to the mechanic as a remedy. We have known several variations of the ball axle, all miserable failures. We know a coach-maker in this city who finished a carriage with a set of axles referred to by the *scientific man*, and on its first trial two or three wheels came off in the street, leaving the boxes *on* the axle. This was when the "balls" were at the collar end of the box, and could not be properly wedged. Afterwards they were changed to the nut end of the box on the axle, in which position they can effect very little in making the carriage run easy, but are a very great disadvantage to the wheels, by cutting away the hubs for their reception so as to ruin them entirely.

GAUGE FOR SETTING AXLES.—Our readers will rejoice to hear that our friend Harper has taken out letters pa-

tent for a gauge for setting axles. This is something we all very much need, and should it meet the expectations of the craft, two parties, we hope, will be benefitted—the inventor and his customers. We design to refer to this subject again, when we hope to be able to present our readers with an illustration and a further description of the instrument than we have space for this month.

WHEELWRIGHTS ASKING HIGHER WAGES.—The journeymen wheelwrights in New York, after several meetings held for the purpose, have obtained an advance of eleven per cent. on former wages. This business seems to have escaped the effects of the war, so detrimental to the interests of carriage-makers generally, and the men are getting \$10 per week.

A NOVEL WHIFFLETREE.—A Maine inventor thinks he has discovered a plan for avoiding accidents where horses become frightened and run away. His whiffletree is made hollow, and strengthened by an iron plate on the under side. Through the channel in the wooden portion he passes a leather strap, which is made to play over rollers at each end. To this strap at the ends the traces are firmly fixed. The *whiffletree* is a stationary one, but the action of the horse and the motion of the carriage is such that, aided by the rollers, the leather strap works with ease, without noise or clatter. So much for the whiffletree—we pronounce it worthless.

LAW OF THE ROAD.—Some remarks on this subject were given on page 178, Vol. III. A cotemporary gives as a reason why teams going in different directions, in this country, are required to turn to the right, the following: "When heavy four and six horse teams were chiefly used, the driver either rode the saddle-horse, or walked beside him, on the left side. This would make it more convenient for him to keep the right, in order to avoid collision. Drivers of two-horse teams almost universally occupied the left of the seat, and hence could better turn to the right." A better reason, we think, is found in the fact that it is much easier for a teamster to make his *cattle* "gee" than "hoy" on the road. Ask any farmer, and listen to his answer.

## LITERARY NOTICE.

FOR special reasons, the present number of our Magazine was kept back a few days. The delay affords us the opportunity of noticing the January number of that excellent monthly, *The Atlantic*. While nearly every other publication in the land has been compelled to raise the price or discontinue, the Atlantic for January (commencing a new volume) gives 144 pages at the low price of 25 cents—cheapness combined with the excellence of the contents unparalleled in periodical literature. The number before us contains a Christmas Story, by N. Hawthorne; An Essay, by Gail Hamilton; In the Half-way House, by J. R. Lowell; A Letter to the Women of England, by Mrs. H. B. Stowe, in answer to one from them six years ago. We hope England's ladies will read it carefully, and set about persuading their male friends to act more in accordance with their former principles, and not *now* give occasion to the world to stamp them as a nation of hypocrites hereafter forever. There are many superb articles in the number, which we recommend our friends to purchase and read for themselves.

[Reported expressly for the New York Coach-Maker's Magazine.]

### AMERICAN PATENTED INVENTIONS RELATING TO COACH-MAKING.

August 12. IMPROVEMENT IN VELOCIPEDES.—Alexis Longett, of New York City: I claim mounting the carriage body on three wheels, C, C, E, arranged on independent axles, *a*, and imparting motion to two of said wheels, C, C, separately by cranks, J, through the medium of gear-wheels, *e*, *f*, bands, *n*, *q*, and grooved pulleys or sheaves, K, *m*, *s*, secured respectively on independent axles, *l*, *a*, *o*, when said parts are arranged to operate in the manner and for the purposes specified. [This patent is intended for the use of adults, on common roads, to be propelled by the hands of one of them, and therefore has a legitimate claim to a notice in this Magazine.]

19. IMPROVEMENT IN CARRIAGE SPRINGS.—G. M. La Baw and P. F. Campbell, of Jersey City, N. J.: We claim the toggle-bars, *c* and *g*, fitted as set forth, in combination with the slide-bar, *h*, and spring, *m*, in the manner and for the purposes specified.

26. IMPROVEMENT IN THE FIFTH-WHEEL OF CARRIAGES.—R. M. Stivers and G. W. V. Smith, of New York City: We claim the combination of the stay rod or spring brace, G, with the perch, A, front axle, C, and parts *a* and *b*, the whole constructed and arranged in relation to each other, as and for the purpose set forth.

IMPROVEMENT IN MACHINES FOR PUNCHING LINCHPIN HOLES AND CUTTING OFF THE JOURNALS OF AXLES FOR WAGONS, &c.—S. H. Hartman, of Pittsburg, Pa.: I claim the combination of the clamps, the cutter, and the punches, for holding, cutting off, and punching the linchpin holes in the journals of wagon and other similar axles, the mechanism being constructed and operating substantially as herein described.

IMPROVEMENT IN CARRIAGE PROPS—(RE-ISSUE).—Chauncey Thomas and D. P. Nichols, of Roxbury, Mass., assignees of Chauncey Thomas, aforesaid. Original letters patent, No. 18,254, dated Sept. 22, 1857. We claim the improved carriage prop, as constructed with a screw or a loose shoulder cap, D, combined with a joint-bar standard, A, and arranged between the leather, L, and the joint-bars, G, H, all placed on the standard, or the latter passing through them, and secured in position by the nut, I, substantially as described.

Sept. 2. IMPROVED HOLDBACKS FOR CARRIAGES.—T. F. Griffiths, of Dadsville, N. Y.: I claim the employment or use of the clasp, C, and the hook, B, they being constructed substantially in the manner specified, and operating conjointly for the purposes set forth.

IMPROVEMENT IN MACHINES FOR UPSETTING AND STRETCHING TIRES.—Charles Seymour, of Laporte, Ind.: I claim, *First*, the frame, B, sliding bed-plate, *c*, with its rack, D, sector, E, the stationary jaw, J, and the adjustable jaw, K, when arranged to operate in combination with the eccentrics, G, G, G, the said parts operating together in the manner and for the purpose set forth. *Second*, I also claim, in combination with frame, B, sliding bed-plate, C, rack, D, and sector, E, the punch-stock, *l*, die stand, F, and die, N, when the several parts are arranged in the manner and for the purpose specified.

IMPROVEMENT IN ATTACHING THILLS TO AXLETREES.—Benjamin Rice, of Hastings, N. Y.: I claim the employment of the oblong eye, B, in combination with the steel head, *a*, loose box, E, spring, F, and pin, C, in the manner herein shown and described.

IMPROVEMENT IN HUBS FOR VEHICLES.—Alexander Moffit, of Brownsville, Pa.: I claim, *First*, The box, *a*, in combination with the part *b*, and parts *c*, *d*, *e*, with their appendages or flanges, substantially as described. *Second*, The pins, *p* and *q*, with their fastening screws, *p'* and *q'*, in combination with holes in the lips of the cup-shaped flanges, *d'* and *f'*, as described. *Third*, The screw nut, *d*, and flange, *d'*, for tightening the disk, *c*, and flange *c''*, upon the ends of the spokes. *Fourth*, The

screw nut, *f*, with its flange, *f''*, and imperforate diaphragm, *h*, constructed in the manner and for the purpose specified. *Fifth*, The semi-elliptical or semi-oval mortise, *e'* and *e'*, constructed in the manner and for the purposes set forth.

9. IMPROVEMENT IN SECURING BOXES TO WHEEL HUBS, &c.—Jacob Kritsch, of Binghamton, N. Y.: I claim the arrangement of the perforated flanch, *d*, with the screw-bolts passing through it, in combination with the screw, *e*, upon the exterior of the box, B, so that by unscrewing the box, access may be had to the inside of the flanch, for the insertion or removal of the screw-bolts, as herein shown and described, for the purpose set forth.

HOLDBACKS FOR WHEELED VEHICLES.—J. S. Swan, of Mongaup Valley, N. Y.: I claim the arrangement of the levers, F, F'', and slides, *b*, *b*, in combination with the cords or chains, *d*, *e*, all applied to a wheeled vehicle, and operating in the manner shown and described.

16. IMPROVED METHOD OF SECURING CROSSBAR AND SHAFTS TO VEHICLES.—L. T. Hazen, of Coventry, N. Y.: I claim, *First*, In casing the ends of the crossbar and shafts in the socket thill iron, and securing the same with internal wedges, in the manner and for the purposes herein set forth. *Second*, I claim the oil chamber, *z*, in the clip iron, F, in combination with the rolling socket, I, and the shaft or thill iron, A, the whole being constructed and operating substantially as herein specified.

23. IMPROVEMENT IN MACHINES FOR UPSETTING TIRES.—John M. Brahn, of Red Bank, N. J.: I claim the bed-plate, A, provided with parallel recesses or slots, *a*, *a*, in combination with the bar, F, screw-rod, D, and nut, E, or an equivalent means to operate said bar, as and for the purpose herein set forth.

IMPROVEMENT IN MACHINES FOR UPSETTING TIRES.—G. Danielson, of Boston, Mass.: I claim, *First*, The attaching of the jaws, D, J, to vertical bars, E, K, one of which passes through the platform, B, and the other through the neck-piece of the plates, L, *h*. *Second*, The arrangement of the jaws, D, J, bars, E, K, levers, F, M, spring, I, and pawls, G, N, in combination with the stationary ledge, C, on the platform, B, the spring, P, lever, Q, and the sliding neck-piece, *f*, provided with the plates, L, *h*, through which the bar, K, passes, and to which the lever, M, is connected, substantially as and for the purpose herein set forth.

IMPROVEMENT IN MACHINES FOR UPSETTING TIRES.—Joseph Robison, of Potter Centre, N. Y.: *First*, I claim the plate, A, when made as specified. *Second*, I claim the band, F, when made as specified, and used for the purpose set forth. *Third*, I claim the roller, B, clasps, C and C, and connections, D and D, when constructed and arranged as and for the purpose specified.

IMPROVEMENT IN SHIFTING CARRIAGE TOPS AND BACKS.—R. M. Stivers and G. W. V. Smith, of New York City: We claim the shifting rail, C, having two or more supports, *d*, feet, *e*, and screw or bolt ends, *b*, rigidly welded thereto, or forged therefrom, in combination with the seat frame, A, and nut, *c*, substantially as and for the purposes set forth.

30. IMPROVEMENT IN ATTACHING THILLS TO AXLES.—Lyman Derby, of New York City (antedated, Aug. 19, 1862): *First*, I claim the longitudinal arrangement of the bolt, E, with reference to the thills, in combination with the thill irons, B, substantially as described, and for the purpose hereinbefore set forth. *Second*, I also claim the jack, having a mortise longitudinally through it, in combination with the bolt, E, and the thill irons, B, substantially, as described, and for the purposes herein before set forth. *Third*, I also claim the use of the recess, H, formed in the sides of the mouth of the mortise in the jack, substantially as described, and for the purposes herein before set forth.

IMPROVED MACHINE FOR BORING HUBS.—G. T. Pearsall, of Apalachine, and S. A. Garrison, of Union, N. Y.: We claim, *First*, The securing of wheel, C, to a supplemental frame, B, containing the working parts of the machine, which frame is attached

to the fixed frame, A, when the latter is in a horizontal position, as and for the purpose specified. *Second*, The nut, E, provided with an external spherical case,  $j^*$ , of soft metal cast around it, in connection with the spherical socket,  $j$ , formed in or between the plates,  $f, k$ , the case,  $j^*$ , and nut, E, being prevented from turning in the socket,  $j$ , by a projection,  $K'$ , substantially as herein set forth. *Third*, The disk or head, H, formed of the two plates,  $o, p$ , fitted in the plate,  $e$ , of the frame, C', in connection with the slide, I, screw, D, and nut, E, all arranged for joint operation, as and for the purpose set forth.

**IMPROVEMENT IN CARRIAGE JACKS.**—C. H. Paine, of Providence, R. I. (assignor to himself and Howard Tilden, of Philadelphia, Pa.): I claim the new or improved arrangement substantially as described, of the bars, A, B, and the levers, C, D; also the combination and arrangement of the toggle or link, F, with the levers, C, D, and their supporting frame, the whole being made to operate as explained.

**Oct. 7. IMPROVEMENT IN SELF-WEIGHING CARTS.**—Edwin Blackman (assignor to himself and J. S. Taylor), of Danbury, Conn.: I claim the steelyard, E, and platform, C, in combination with steelyard, F, and prop, D (or spring scales suspended from the cattle), when constructed and applied to a cart, substantially in the manner and for the purposes hereinbefore set forth.

**14. IMPROVEMENT IN WHIFFLETREES.**—A. M. Beebe, of West Bloomfield, N. Y.: I claim the combination and arrangement of the equalizing eveners, A, B, and D, with the whiffletrees,  $a, b$ , and  $d$ , for three-horse teams, substantially in the manner specified.

**21. IMPROVEMENT IN MACHINES FOR MAKING NUTS.**—T. R. Taylor, of Cleveland, O.: I claim the sliding frame, G, in combination with the jaws, I, I, and dies, M and N, when constructed and operating substantially as and for the purpose specified.

**28. IMPROVEMENT IN WAGONS.**—G. W. Buss, of Boston, Mass.: I claim, *First*, Supporting the wagon by means of the lever, or levers and springs, arranged with regard to each other and to the axle, substantially as described, so that the spring or springs shall be acted upon at such a point of the lever as receives comparatively the shortest play or motion, as set forth. *Second*, In combination with the lever or levers, the crossbar,  $l, l$ , or  $r, r$ , as described, and for the purpose specified. *Third*, In combination with the lever or levers,  $i, i$ , and axle,  $c, c$ , the radial arms,  $f, f$ , the whole operating together as set forth.

**IMPROVED MODE OF CONNECTING FELLIES OF WHEELS.**—Josiah Eveland, of Elizabeth City, N. J.: I claim having the sockets, C, C', provided respectively with a tapering dovetail tenon and a tapering dovetail recess, fitting and operating together in the manner herein shown and described, so as to form a firm but easily separable connection between the ends of the fellies, and prevent all lateral and inward spreading or bending of the felly ends, as set forth.

**IMPROVED MODE OF ATTACHING AND DETACHING WHIFFLETREES.**—John Laughlin, of Gettysburg, Pa.: I claim the arrangement of the spring-bolts, E, E, the bent levers, F, F, the boxes, I, I, the straps, G, G, J, and the bar, H, constructed and operating in the manner and for the purpose herein specified.

**IMPROVEMENT IN SELF-ACTING WAGON BRAKES.**—Daniel Sager, of Albany, N. Y.: I claim the brake-block, X, formed as shown, and fitted to revolve freely upon an axle from the extremity of the brake or bar, for the purpose set forth. The mode of construction by which the brake-block is fitted and secured upon the axle, to wit, the combination of the orifice, M, the groove,  $a, b$ , and its flange,  $t$ , with the axle, C, flange,  $f$ , and space,  $y$ , substantially as described, and for the purpose set forth in the above specification.

**Nov. 11. IMPROVEMENT IN AXLES AND REACHES FOR VEHICLES.**—S. O. Post, of Chicago, Ill., and E. J. Post, of Vienna, N. J.: We claim the application of corrugated sheet metal to bars or

bolsters, for wagon axles, and the mode of securing the arms to the same, in the manner described, and for the purpose herein specified.

**IMPROVEMENT IN COUPLING THILLS TO AXLES.**—Nathaniel Richardson, of Byberry, Pa.: I claim the coupling bolt, C, in place, and preventing its rattling, and at the same time allowing it to be easily and expeditiously inserted or removed, by means of the retaining spring, D, resting against it, and the coiled spring,  $c$ , or its equivalent, reacting to throw it outward, the whole being arranged, combined, and operating substantially as herein set forth.

**18. IMPROVEMENT IN GAUGES FOR CARRIAGE AXLES.**—Henry Harper, of Berlin, Wis.: I claim, *First*, The method herein described of giving the proper pitch to carriage wheels by means of the bevel, Fig. 1, and the scale, Fig. 2, substantially as set forth. *Second*, I claim the use of the bevel, constructed as set forth, for the purpose of giving the proper pitch to carriage wheels, substantially in the manner above set forth. *Third*, I claim scale, Fig. 2, when used in the manner above set forth, for the purpose of giving the proper pitch to a carriage wheel. [We intend to give this patent a more extended notice hereafter.]

**IMPROVEMENT IN MACHINES FOR ROLLING TIRES.**—Wm. Harris, of Jersey City, N. J.: I claim the combination and arrangement of the rollers, G, E, and F, in the adjustable carriage,  $e$ , substantially as and for the purpose herein described.

**Dec. 2. IMPROVED MACHINE FOR CUTTING TENONS ON WHEEL SPOKES.**—J. M. Simpson, of Maultville, N. Y.: I claim, *First*, The cutter-bars, E, E, placed in the reciprocating frame, B, and used in connection with the adjustable keys or wedges,  $j, j, s, s$ , all arranged substantially as and for the purpose set forth. *Second*, The adjustable bed, H, provided with the gauge, M, guide, J, and clamp, K, when said bed is used in connection with the cutter-bars, E, E, and reciprocating frame, B, and arranged therewith as and for the purpose specified. *Third*, The combination of the cutter-bars, E, E, reciprocating frame, B, and adjustable bed, H, all arranged for joint operation, as and for the purpose set forth.

#### TO READERS AND CORRESPONDENTS.

BACK VOLUMES of this work will be sold, in numbers, for \$3; when bound, for \$3.50, to which, if sent by mail, 48 cents must be added to pre-pay postage; if two or more volumes are called for at one time, they can be had for \$3 each, or will be sent by express, at the purchasers' expense, at the same price. The subscription to the Fifth Volume, now in course of publication, will be (in consequence of the advance in paper and printing) four dollars, IN ADVANCE, for the twelve numbers; and these will be issued, in 1863 for Jan., March, May, July, Sept., Nov., Dec., and afterwards monthly until the close of the volume in May, 1864. Should the war end, and business again resume its natural channel, we intend to resume and publish monthly, as formerly, the Sixth Volume in June, 1864. Any of the old numbers can be had for 30 cents each; the new numbers will be 35 cents each. It will thus be seen that we give our friends the benefit of low prices for old stock, and we trust they will allow for the necessity which compels us to charge an advance on our present issues, for the reasons above stated, while the present exigencies continue.

COVERS, handsomely gilt, and ready for binding the numbers therein (which any binder will do for 35 cts.), can be had at this office for 54 cents. When mailed (the postage on which we prepay), 66 cents. Any volumes left with us will be bound for \$1 each in our uniform style. This advance is caused by the rise of book-binder's material.

AGENCY.—Our friend Mr. Henry Harper, who is traveling in the West, is authorized to take subscriptions for us, and receipt for moneys paid; and any contract he enters into concerning this Magazine will be honorably carried out by the Publisher. In Canada West, Messrs. McKinley, Cowles & Co., at St. Catharines (dealers in carriage-hardware), will act as our local agents.



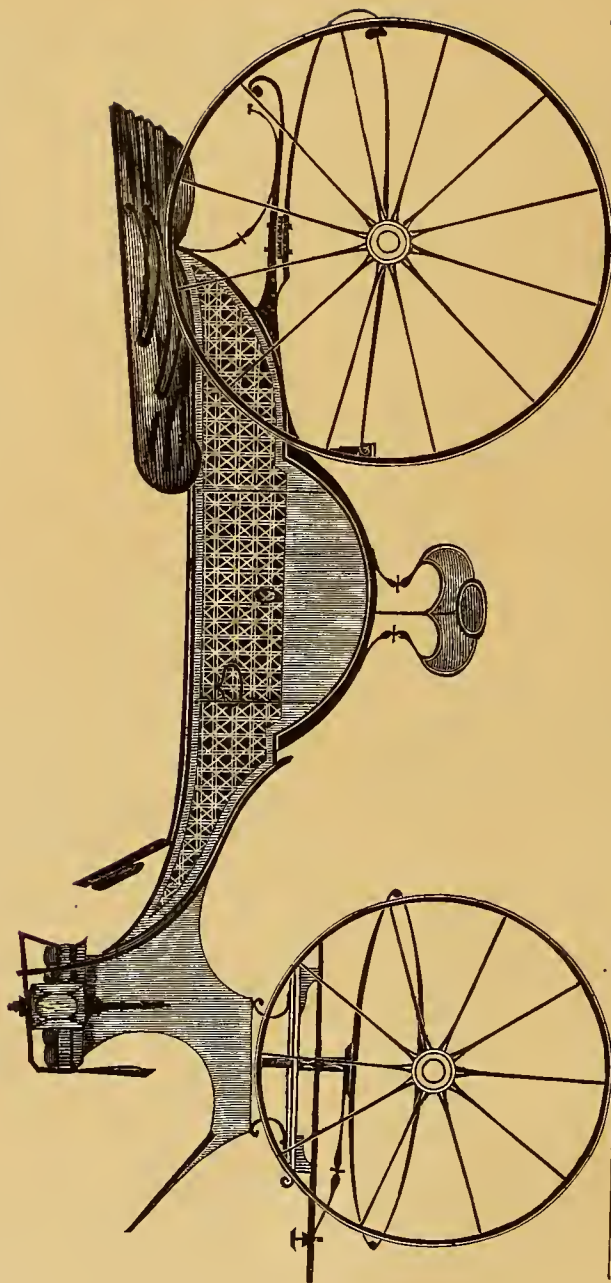

BELGIAN CALECHE.— $\frac{1}{2}$  IN. SCALE.

*Engraved expressly for the New York Coach-maker's Magazine.—Explained on page 25.*



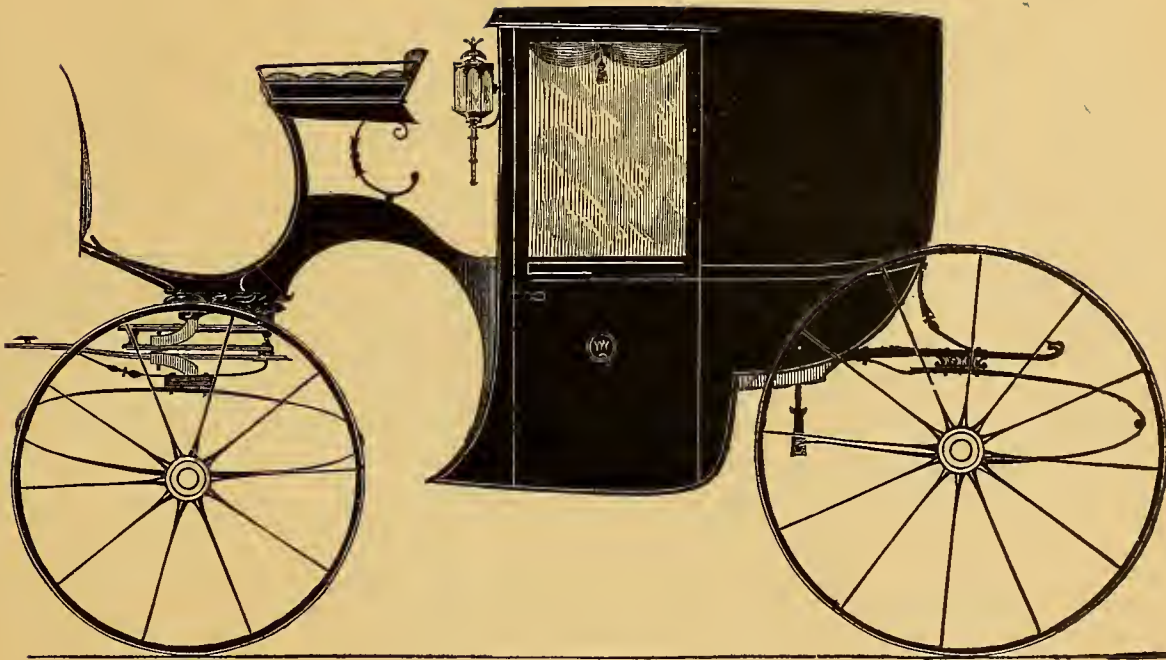

SINGLE-HORSE COUPÉ.— $\frac{1}{2}$  IN. SCALE.

*Engraved expressly for the New York Coach-maker's Magazine.—Explained on page 25.*





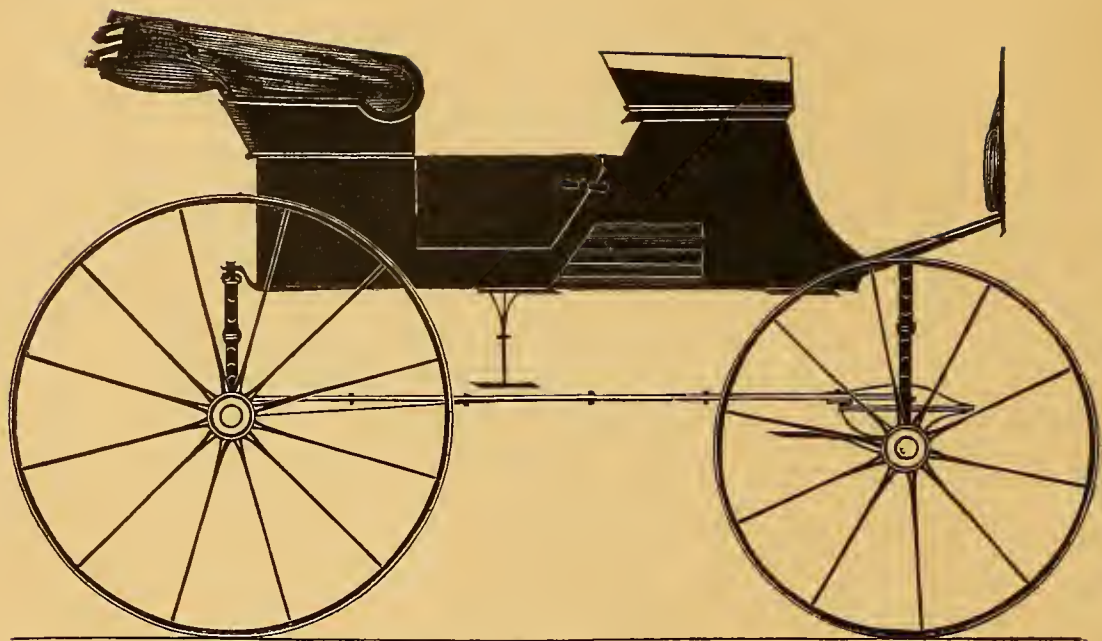

HALF-CUT-UNDER PHAETON.— $\frac{1}{2}$  IN. SCALE.

*Designed expressly for the New York Coach-maker's Magazine.—Explained on page 25.*



ROUND-CORNERED BUGGY.— $\frac{1}{2}$  IN. SCALE.

*Engraved expressly for the New York Coach-maker's Magazine.*

*Explained on page 26.*





DEVOTED TO THE LITERARY, SOCIAL, AND MECHANICAL INTERESTS OF THE CRAFT.

Vol. V.

NEW YORK, MARCH, 1863.

No. 2.

## Mechanical Literature.

### THE MOTIVE-POWER OF WHEEL-CARRIAGES.

BY H. H.

(Continued from page 189, Vol. IV.)

Excuse the digression into which we have been led, and we will endeavor to explain why the wear on the axle is more in proportion, where the bearing is unequal, than the mathematical calculation of the number of pounds pressure would show it to be. Friction always creates heat, from the particles of the two substances that are rubbed together interlocking each other and then breaking off; this we call wear. To prevent these particles interlocking each other, we use some kind of lubricating matter—generally oil. It is apparent that the harder the substances are pressed together, the more liable the particles are to lock—so much so, that it overcomes the resistance the lubricating matter possesses for keeping them apart. Now, if there is twice as much pressure on one end of the arm as on the other, it is plain that the end which receives the most pressure is the end the most liable to remove the grease and allow the particles of iron to lock into each other, which makes the wear or breaking of particles so interlocked to generate the heat which always follows friction. Heat softens the iron, besides having a tendency to remove the grease which is used for lubrication; and this brings on what we call “cutting out,” which is no more nor less than the iron becoming soft by heat, so that it is easily displaced by pressing the two parts together. I have known either the box or axle to be worn out in two or three days, which, under favorable circumstances, would have lasted in constant use three or four years. Mechanics often have a very poor excuse when their work meets with such a fate. After examining the box or axle (whichever it may be), or both, they turn to the poor man who has been duped by it, and say: “You see that the castings are too soft; it will sometimes happen so; nobody can guard against it.” Nothing can be farther from the truth: it is the mechanic alone who is to blame for having made the bearings unequal.

A soft piece of sheet-iron placed in a lathe and made to revolve, will cut a piece of hardened steel, simply by

the process of heating which the steel undergoes before the iron. It is not always the hardest metal which friction wears the least, but, in very many instances, it is affected the most by it; yet, for reasons which we shall hereafter explain, we think it best to use hard metal for both axle and box. On account of the foregoing reasons, we cannot mathematically calculate, from the amount of pressure an axle has, the exact time it will wear; because it depends very much upon what we may almost term an accident whether they are placed in the most favorable position to resist the action that friction may have on them or not. A little heat to the axle, which a wrong pitch in setting is liable at any time to bring on, may consume the grease separating the two pieces of iron; and when they come together, a few hours may do the damage that would have otherwise required years to have done.

The length of the axle-arm which is the most proper for use, and which would be the least liable to waste motive-power, is, like many other questions, not easily answered with precision; for this reason—the inequalities of the road are such that we cannot tell how much higher one wheel will be raised than the other while the wagon is being drawn over an uneven road.

If a wheel drops into a deep rut, it seems as if this unfortunate position had brought on at once all the adverse conditions that can be arrayed against the use of its mechanical power. In the first place, the center of gravity of the load is brought nearer to the depressed wheel, which makes the heft to be lifted greater than at any other time, and the leverage to lift it is shortened, as in the case of other obstructions over which it has to be raised; and, in addition to the above difficulties, if the depression is so great as to throw the angle of the spoke out of a perpendicular beyond the corresponding length of the axle-arm and box, the friction of the pressure on the axle-arm and box becomes double to what the weight would make it at other times. This double action of friction is what we call cramping the wheel, which is the weight acting as a pry on the upper side of the point of the axle, and resting on the under side of the axle at the shoulder, creating double friction by a pressure both on the under and upper side of the axle-arm. On the track that we have in this locality [Berlin, Wis.], which is 55 inches wide, this doubling the friction would not commence on an 8-inch axle-box until the wheel had been depressed below or raised above  $9\frac{1}{4}$  inches, and every inch

that is depressed below or raised above  $9\frac{1}{4}$  inches increases the common friction double, the same as  $62\frac{1}{2}$  pounds on a 500-pound load to the wheel, providing that the wheel is 24 inches from the axle to the periphery. On a 10-inch axle-box, this uncommon increase of friction does not commence until the rise or depression of the same wheel exceeds  $11\frac{1}{2}$  inches.

On a common road the grade is seldom raised so as to raise the wheel on one side more than 4 or 5 inches above the other on a 55-inch track; therefore, an 8-inch axle-box is long enough for that, and some to spare. The question now is, the length that will be best adapted to the average depth of ruts. If  $9\frac{1}{4}$  inches is their average depth—or rather, if it is very uncommon that they exceed that—then the 8-inch axle-box is the best; but, on the contrary, if  $11\frac{1}{2}$  inches is the medium depth of ruts, then a 10-inch axle-box is the proper length. Over-going the necessary length has this disadvantage—and only this—that it adds to the weight of the wagon. The heft unnecessarily attached to a wagon is an item that should be more particularly considered than we have been in the habit of doing, for it costs a fraction over \$4.21, taken from the total earnings of a wagon that runs its full time, for every pound that it weighs. This shows how important it is for the mechanic to understand the true nature of the power that belongs to the machinery of a wagon. If he mistakes the lever for the inclined-plane, or any of the other mechanical powers, it is certain that he does not know how to remedy the defect that may occur to the lever; or, if he does not know the cost of the motive-power, he does not know anything about approximating the medium point between a sufficient strength and the least heft that may be attached to a wagon.

At this point of investigating the motive-power of wheel carriages, I deem it proper to digress from our subject, enough to make a personal excuse for introducing so often a recommendation of the Patent Homogeneous Cast Steel, which we see advertised in this Magazine. It is so common to purchase recommendations, and so difficult to distinguish between those that are purchased and those that are the honest convictions of the one giving them, that it seems proper for me to say that, up to the time of writing this article, I have never exchanged a thought or word, to my knowledge, with any of the proprietors or agents of said steel, nor do I want any one to receive from me any recommendation in the premises, only as he gets them from the philosophical inductions of the facts presented. From the recommendation of Mr. Saunders, who is said to be a superior workman in iron, we learn that this steel combines the toughness with twice the hardness and rigidity of iron. The last two qualifications are as necessary for the tire as the axle, if not more so. Now the conviction has been forced on my mind by plain mathematical induction, from the proofs of simple multiplication and division, whenever the subject of the weight of the wagon has been connected with motive-power, that the proprietor has made his claims to the usefulness of this steel far too limited. Why not the most suitable material for draught-wagon axles and tires? The extra expense cannot be urged until it reaches as much as \$4.21 per pound on the steel, against 6 cents on the iron. The bill would stand thus:

Cost of 1 lb. of steel for tire at 12c. per lb.....	\$0.12
Cost of motive-power to wear out 1 lb. of steel.....	4.21
Total.....	\$4.33

Cost of 2 lb. of iron for tire, at 6c. per lb.....	\$0.12
Cost of motive-power to wear out 2 lb. of iron, at \$4.21 per lb.....	8.42
Total.....	\$8.54

The result is—for the iron tire.....	\$8.54
“ “ steel “ .....	4.33

Balance in favor of steel tire.....\$4.21

This is a mathematical demonstration, which forces itself on our minds whenever the value of motive-power is considered, no matter who it hurts or helps; and it is one of importance; for if, by the use of steel tires and axles, we can lessen the heft of a draught-wagon 30 pounds, it will earn \$126.30 more than it otherwise would with the same motive-power. Where can be the objection to using steel exclusively for axles and tires on heavy wagons?

It does not seem advisable to vary much from 8 or 10 inches as the proper length to an axle-arm and box for a draught-wagon. To make it less than 8 does not seem as though proper provision was made for the liability that uneven roads would have to cramping the wheel; and over 10 inches seems as though too much expense of motive-power—in the way of additional heft on the wagon—was laid out for attaining the object. In a wheel, the diameter of which we are speaking about, every inch of the length of the box provides for  $1\frac{1}{8}$ -inch rise or depression of the wheel, without its cramping the axle in the box, and no more.

We sometimes see the axle-box placed in the hub, so that the center between the two ends is on one side of the tread to the wheel when it is in use, and on level ground. This is a most abominably stupid practice, and plainly shows that the man who commits such a blunder has an imperfect idea about the necessity of the equal bearings that a wheel should have. It not only makes the bearings unequal, but it subjects the wheel to all the liable crampings of a shortened box, and of course it unnecessarily adds to the heft of the wagon, just as much as that amount of inequality will weigh; which—axle, box and hub together—cannot be much less than 2 pounds to one wheel, on an ordinary lumber wagon, and which will amount to 8 pounds for the four wheels. That is bringing on three important obstacles to the motive-power without gaining the shadow of an advantage; but, I am happy to say, the blunder is not a frequent one. For a buggy, or any vehicle that is to be used on uniformly good and level roads, the axle-boxes should be made much shorter, because the liability to be cramped is so seldom on such a road that it would not pay for the extra amount of motive-power that it would require to carry around the preventive for a thing that would seldom occur, and if it did occur, the surplus motive-power, which a light carriage always has at hand, would be cheaper to us on such occasions. The case is entirely different with a draught-wagon. It is generally so that nearly all the motive-power that a team can lay out is used to move the wagon over the usual road; and if it meets an obstacle that cramps the wheel, the team has not enough power in reserve to get over that one spot, and is stopped entirely—which would be a greater loss than having to draw the extra weight which would be required as a preventive for such conditions. The axle-arm of a light buggy, where lightness is an object to be attained, can be reduced to 5 inches without



any inconvenience to the motive-power, as a general thing; and, on roads where the grade is very level and uniform—as will be found in cities—a 4-inch arm and box would be sufficient.

(To be continued.)

## REPORT OF CARRIAGES IN THE LONDON INTERNATIONAL EXHIBITION, OF 1862.

(Concluded from page 7.)

AMONG other changes is the increased use of the lever-break for carriages principally used in hilly parts of the country. Since their first introduction they have been much improved in simplicity, efficiency, and economy: many of the British carriages are fitted in this manner. It not only increases the safety of a carriage, but dispenses with the necessity of taking a second servant, as is necessary to put on and remove the common drag-shoe. A supply of spare, hard-wood skids are generally furnished, so that new ones can be readily fixed by the servant if once shown how to set about removing the worn skids, and replacing them by new ones.

A mode of applying pressure to both the back and front parts of the hind wheel of a carriage has recently been introduced, and possesses advantages for carriages to which a pressure in front only cannot advantageously be applied.

In consequence of many improvements effected in the manufacture of landaus, the chief of which is the great reduction in weight, the demand for them has recently much increased. They are well suited to the variable climate of the British Isles, as they can be readily changed from an open to a close carriage, and *vice versa*. They do not, however, admit of that beauty of outline that is capable of being given to an entirely open or entirely close carriage; but from the amount of care and contrivance displayed—as evinced in many of those shown, they have such qualities as render them very convenient and desirable family carriages, either for London or country use. There are shown several ingenious plans for enabling the heads of landaus to fall flatter than has been hitherto considered practicable; they have the advantage of converting the landau into a more open carriage than formerly, besides preventing an obstruction to the view. Most of these carriages are hung at such a very moderate distance from the ground, and with covered steps, that it is optional whether one or two servants shall accompany them.

Carriages of the wagonette type, where the sitters in the back seats are placed sideways and vis-à-vis, are come much into use of late years; they possess the advantage of carrying a greater number of persons on a carriage of given weight than any other on four wheels.

The first, or nearly the first of these, was built in the year 1845, under the personal direction of the late Prince Consort, for the use of Her Majesty and the Royal Family. It had many ingenious contrivances suggested by the Prince, with whom and Her Majesty it always remained a favorite carriage for country excursions. There are so many varieties of carriages of this type, and so much ingenuity has been bestowed on them, that it can hardly excite surprise that they are much appreciated by those who use carriages, especially in hilly parts of the country, where a compact, serviceable, and economical carriage is in many cases indispensable.

A revival of an almost obsolete carriage, "the four-in-hand coach," has taken place within a few years. They are generally built on the model of the best mail and stage coaches of former times, but with a much higher degree of finish. It may appear very easy to the uninitiated to build such a carriage, merely on the lines of former days, but in fact they require such careful and accurate planning of the several parts, individually and combined, that only those who have given much attention to them, and have to a certain extent been tutored by gentlemen who drive them, have been successful in turning out carriages of the kind that in most points meet their requirements. One of these carriages is the trophy of the British coach-builders, and is now in a conspicuous position in the Nave of the Exhibition building. The revival of a taste for such carriages is worthy of remark, as the management of a "team" not only requires great bodily strength, good nerve, and a quick eye, but being an expensive amusement, is mostly confined to the aristocracy and persons of wealth, with whose habits it is principally associated, and indicates something of that vigor of body which generally distinguishes the British gentry.

As a matter of convenience, comfort and safety, it is desirable that rather more attention should be devoted to the position and pitch of the footboards of driving seats. To many carriages this remark does not apply, but to a great number it does. In planning and executing a driving seat, were a master or workman to get on it and make it comfortable for himself, it would probably remain so for the next occupant, who, if in charge of young or restive horses in a crowded street, would be much assisted by having a firm seat, combined with a good hold on his footboard.

As regards carriage drawings and designs, one London firm shows a series of most of the carriages now generally made by the principal London manufacturers. There are also several other drawings of carriages well designed: in fact, the London artists supply not only the London and many of the provincial builders with carriage drawings, but large numbers are sent to the principal continental coach-builders, who get their fashions from London.

There are shown some specimens of the present state of the art of heraldic painting in England, as well as some specimens of the style now fashionable for monograms in combination with crests, &c. This is a subordinate branch of art that is capable of development; as a good group of letters, &c., well designed, quaint, but not obtrusive, has a tendency to give a pleasing finish to a well-appointed carriage.

As regards the manufacture of silks for carriage linings, although not a very extensive branch of the English silk trade, it is of some importance; and great improvements have been made as regards the dyeing, the brilliancy of the surface, and above all, in the patterns. It seemed hardly to be considered that a large bold figure well adapted for drawing-room curtains, was most ill placed in the interior of a carriage, to which it gave a flashy and uncomfortable appearance, from the partial concealment of the pattern by the tufting of the cushions, squabs, &c. Smaller and more suitable patterns are now made, much to the improvement in appearance of the majority of English carriage linings.

Owing to the greatly enhanced price of leather, from various causes, of late years, a great impetus has been

given to ingenious persons for the production of useful and economical substitutes, which are now produced in the form of waterproof goods of such excellent quality that they replace much of the leather formerly used.

Although heraldic and metal chased ornaments are not so much used now as formerly, progress has been made in the beauty of design of such where required.

A minor improvement in the substitution of a wooden frame with stuffed top covered with cloth for driving seats may be mentioned: it retains its shape better than ordinary hair cushions, and does not absorb so much moisture when exposed for a long time to heavy rain; it can also be more readily dried when wetted.

Special periodical journals devoted to individual manufactures are a sign of the stirring times in which we live, and when conducted with talent and energy are capable of assisting in carrying on rapid improvement and bringing forward useful inventions to the notice of those who are particularly interested in their successful application. They are also a means for interchange of ideas on an infinity of theoretical and practical matters; and have the means, when ably conducted, of diffusing truth and suppressing error by the force of argument, and saving much valuable time and money in fruitless experiments.

Although France led the way as regards periodical literature connected with carriages, and America was the next in the field, England for nearly three years has supported its "Coach-builders' Art Journal." During its early existence it had to encounter many difficulties and prejudices; but from the experience gained, most of the difficulties being now overcome, and much of the prejudice having subsided, the publisher has obtained a large circulation for it in this country and over most of those parts of the world where carriages are built. With an efficient staff to edit and furnish designs; it may raise the art of coach-building to a higher position than it at present holds. There have been recently tried a variety of processes for carriage illustration besides the usual hand-made designs furnished by the artist, which, up to a very recent time, were the only ones suitable for coach-builders. They consist of steel and copper-plate engravings, lithographs, zincographs, wood engravings, photographs from finished carriages, and photographs from carriage drawings, either exact to copy, enlarged, or in miniature, for transmission in ordinary letters by post.

A great advantage to coach-builders are the covered carriage trucks kept by some of the railway companies for the transport of private carriages to distant places: with such contrivance a coach-builder is enabled to deliver a new carriage to the most remote parts of England or Scotland almost as perfect as it leaves his hands; the expense of packing is saved, and the marks left by the packing are avoided. It is hoped that before long such covered trucks will be kept in sufficient numbers by all the railway companies, as the present open trucks are most destructive to all private carriages, from the quantity of ashes and filth deposited on them by the engine, which seriously injure the varnish and soil the linings.

An unlooked-for consequence of such exhibitions at the present was perhaps hardly contemplated by their royal founder: it happened that the British coach-builders who contributed to the Paris Exhibition of 1855 were brought together frequently in furtherance of their mutual interests, and almost at the moment of their dispersion it was proposed that some useful object should be set on

foot. A charitable institution found most support, and the subject was immediately placed before a public meeting of the trade, where it met with equal favor. It has since collected upwards of 6000*l.* for charitable purposes; has an annual income of between 500*l.* and 600*l.*; assists and maintains twenty pensioners with sums ranging from 10*l.* to 25*l.* per year, besides distributing monthly sums varying from 2*l.* to 10*l.*, for temporary relief to persons connected with coach-building, who have been overtaken by misfortunes.

A somewhat similar institution has recently been set on foot by the workmen engaged in carriage-building; the rules have been drawn up in accordance with the new law, and have been approved by the Registrar-General of Friendly Societies. As it has been founded by some of the most skillful and best conducted of the operatives, and has been supported by many of the principal employers, it is hoped that it will meet with all the success that such provident societies so well deserve, when confined to the legitimate purpose of encouraging provident habits, and relieving distress.

The habits of the operatives engaged in coach-building are much improved; not only is intemperance almost abolished, but most of the men read and write, and many possess good general information on many useful subjects; the free admission to so many public galleries, institutions, and gardens, together with the facilities of excursion trains and steamboats, enable them to spend their holidays in an agreeable, entertaining and economical manner. As the success of coach-building depends much on a knowledge of sound mechanical principles, of the arts of design, and the harmonious combination of colors, it is desirable that the attention of the workingmen should be especially directed to the facilities afforded for acquiring such information; as those who acquire a proficiency in these, as well as in their own special department, would obtain increased remuneration from the advantage that would surely accompany a knowledge of the correct principles on which they work.

The body-makers, carriage-makers, smiths, and others should as certainly be acquainted with mechanical principles, and the art of drawing, as the painter and trimmer, should know how to combine colors to give them their best effect.

The carriage department might have been more complete had it received contributions from the principal London wheelwrights, axle-makers, spring-makers, lamp-makers, and heraldic chasers: there is ample wall space to have shown a large and interesting collection of such manufactures, which are produced in London of the highest quality; it might have led to an export trade for such goods, of which large supplies are now annually drawn by some foreign countries from France and Germany.

The principle of suspending carriages on a single wrought-iron perch, first prominently introduced at the Exhibition of 1851, has produced a great change in the construction of nearly all C-spring carriages now built and has many advantages for small carriages hung low. It is, however, beyond a doubt that for carriages hung high, and requiring double folding steps, the perch of wood and iron combined has the great recommendation of increased safety, as three iron plates and the wood must break before an accident can happen; whereas, the solid iron perch depends for its safety on the soundness of a single weld.

In the French department in the main building are shown two photographs of a state railway carriage recently built for the Pope; its design and decoration are so far in advance of anything yet done in England, that these photographs well deserve to be examined and placed in a more prominent position.

The omnibus (usually drawn in Paris with two powerful, but slow horses) shown by France, for the traffic of the Paris streets, deserves careful examination. These carriages are all made on one model by machinery; and the parts interchange, so that repairs are very expeditiously executed. Although much too heavy for the London traffic with a pair of light horses, and too cumbersome for the crowded traffic of the streets in the city of London, they are comfortable, easy, and safe. The plan of suspending on three springs, both in front and behind, gives greater ease than the short elliptic springs common to the London vehicles. Were such carriages copied, but made shorter and lighter, and were the front box seats (to carry four) added, such carriages would be a great addition to the comfort of many thousands of Londoners, who have to make two journeys daily, for six days in every week through the year, in the stuffy and ill-ventilated London omnibuses, which, by the recent innovation of roof seats, are so constantly overloaded as to strain and wear out the horses very rapidly, besides cruelly taxing them much beyond their strength.

Since the opening of the Expedition there have appeared in London a number of large, commodious, and well-ventilated omnibuses, even somewhat larger than the Paris omnibuses, drawn by three horses abreast. In the first place, the increased comfort to the public is undoubted; the horses seem to work with less strain on their muscles; the omnibuses having a larger base are steadier and safer, and having longer springs they are easier, and being fitted with pressure or lever breaks to the hind wheels, they can be stopped with greater facility. The expense of building the carriages larger, somewhat increases the expense, as does also the addition of a third horse; however, to set against these charges, are the increased number of passengers carried (about one third), with the same number of attendants (driver and conductor), nearly equal expense of repair, and the saving in the wear and duration of the horses, so that the question of working them profitably in London may be considered almost certain.

They might not be available for narrow streets, but many lines of omnibuses scarcely approach the narrow and crowded city streets; the crowd of traffic may at present be a drawback, but the state of the traffic will probably soon be altered. The London railway stations are being so placed as to be easily accessible, and much of the heavy traffic through London will be taken by the connecting lines of railway exchanging the northern and southern, eastern and western traffic, partly by passing through the metropolis, and partly under it. Besides this, the roadway on the Thames embankment will relieve the city traffic of its delays and dangers, and render it safe for others besides the strong and robust to drive or walk in the highway between Temple Bar and the Bank.

In the "Victoria" department is shown a well-balanced car, such as are generally used for passenger traffic in the streets of its towns: although rather heavy and cumbersome to London eyes, accustomed to neatness and high finish, it is probably well adapted for its purpose, espe-

cially as regards the ingenious canopy roof, which can readily be set up or lowered, as the passengers may prefer.

In the English gallery of architectural drawings is shown a well-executed model of Her Majesty's state coach. As the carriage itself (designed by Sir William Chambers) is believed to be the handsomest and most artistic of its kind in Europe, it is worth considering whether the model might not be procured for the national collection, as at least a slight recognition of the art of coach-building, which, in these days, is almost elbowed out of notice by the taste for many pretty arts and manufactures that hardly require more, and many not so much, care and thought as the successful production of the highest class of private and court carriages.

Although the application of machinery to the construction of private carriages has progressed, aided by a well-known firm in Derby, which has for some years devoted attention to the subject, many reasons prevent its general application to private coach-building purposes: some of which are, the great variety of carriages built by each manufacturer, the desire on the part of purchasers to have carriages made to dimensions of their own choice, and the variations of pattern, as fashion indicates the lines that are most favored by those who lead in such matters. These continued changes, in some cases tending to improvement, complicate the details of construction, already sufficiently intricate; whereas it may be cited as a general rule, that the most profitable and advantageous application of machinery is in the production of articles in great quantities as nearly as possible identical, such as the Enfield rifles, Armstrong guns, railway bars, axles and wheels, &c., &c.

The following machines are those that have been found best to answer the purposes required:

Fans for blowing forges, and circular and upright saws—the latter arranged to saw out two felloes at one operation; wood-boring and morticing machines; machines for boxing wheels; wood-planing and shaping machines—the latter fitted with tools for rebating, grooving, moulding, and tenoning; spoke-turning machines; iron-bending machines; shearing, punching, and drilling and screwing machines; paint mills; grindstones for springs and ironwork.

It may be added that in eleven years the tool-makers have not been idle; improvements to facilitate hand-labor have been made, not only by comparing side by side the productions of English makers, but with those of continental and American makers: an intelligent workman, who is paid according to the amount of work he turns out, looks for such aids to his labor, with a keenness sharpened considerably by self-interest, and adapts himself to the work he is required to produce with great ingenuity.

There are certain requisites for coach-building that would improve carriages in several points. For colors, durable blues, lakes and yellows are required; as is also a colorless and durable varnish. Of what avail is it that scientific men invent such beautiful colors as mauve, magenta, and others, if they are at once to be toned down by several coats of brown varnish? Coach-varnish has been much improved of late years; but, until delicate and beautiful colors can be used without being tinted with a film of brown to preserve them, varnish-making cannot be said to have reached perfection.

Were due attention given to the matter, it is probable that manufacturers might be able to produce cloth suitable for carriages that would resist the attacks of moths, which cause much injury to carriage linings, besides loss and vexation to the owners. The green and claret cloths made up to this time become rapidly faded when exposed to the sun in open carriages: this deserves investigation, as it is probable that an improved dye may be used with advantage.

It is believed that the exportation of British carriages has not kept pace with the increase of most other exports: this is probably caused by purchasers directing more attention to lowness of price than the real economy of soundness of quality. A large proportion of the recent exports of carriages have been of so low a quality as to drive away many purchasers to the manufacturers of the continent of Europe and the United States of America. This is a state of affairs that will require time and much effort to bring into a more desirable condition: the matter requires the hearty concurrence of purchasers, merchants, and coach-builders, as it frequently happens that carriages of the lowest price and quality afford the largest percentage of profit.

In conclusion, it may be remarked, that the British show of carriages (with some exceptions) sustains the reputation of the manufacture as to design, comfort, soundness, and good finish, as regards the type of carriages in most general demand at the present time. France follows next, with a small display of soundly built carriages; then follow Belgium, Germany, Russia, and Holland, each with a proportion of sound and genuine workmanship. The English carriage department has been fitted up at a small individual expense to each exhibitor, and shows the carriages in it to advantage: this is not generally the case with the space allotted to the foreign carriages in their respective departments. It should be considered in future Exhibitions, whether some exception could not be made to carriages, and show those of all countries together in one well-arranged department. At present, the Commissioners of foreign States do not seem to know what to do with their carriages, which are displayed in all manner of ways, rarely well, and frequently much to their disadvantage.

Were time permitted, it would be possible to notice many other points of interest, although almost impossible to discover everything worthy of remark in so extensive a collection. Visitors should, therefore, not only examine superficially the objects most prominently displayed, but seek out many interesting objects that are placed in the recesses of the various courts.

In the award of medals, it is worthy of remark that, with few exceptions, those exhibitors have been most successful who have contributed carriages that they are in the habit of producing as ordinary matters of trade: the reason is, that they have had time and opportunities to correct mistakes and to add improvements at their leisure. Where exhibitors have produced something they are unaccustomed to, errors have been committed that experience and comparison will probably rectify, but which have been fatal to their claims for a medal in the present Exhibition.

As some recommendation to the plan of a careful preliminary selection of exhibitors, it may be remarked that the success of France in this respect is instructive. The contributions to the class are small, but they are carefully

selected. Although one medal is given for wheels, and another for a public omnibus, three remain for private carriages; so that it may be seen that a small and carefully selected display takes its proportion of medals with more success than a promiscuous display of the goods of nearly all applicants for space.

It may further be added, that in several cases coach-builders have attempted to adapt their carriages to many purposes. As a general rule, it is better that a carriage should be useful for one or two purposes, than that it should be convertible into several, more or less perfect, according to the ability of the builder and his workmen.

Road vans and wagons were included in Class VI.; and it is evident that railways have created a demand for a class of vans to distribute merchandise and heavy goods in cities and towns. Their construction is required to combine strength, compactness, and reasonable lightness, for facility of rapid movement, with two or occasionally three horses. An excellent example of this class of van is shown in the carriage department; not only is its general construction well suited to its requirements, but the details have been so well contrived, that each gives its utmost strength without superfluous weight; there is also shown a well-contrived pair-horse spring wagon, for the transport of heavier goods, such as coals, corn, flour, &c. Great Britain only shows invalid and garden wheel-chairs; the display is very limited, but good in quality. The invalid in whatever stage of suffering, may be supplied in England with little vehicles that afford the utmost comfort that ingenious contrivers can produce in a great variety of form and modes of suspension, suitable for the different wants and means of invalids.

And lastly comes into notice the little vehicle, so well known to all, "the perambulator." It is a somewhat recent innovation, probably even since the Exhibition of 1851. From the immense number that have been made, and continue to be made, they have evidently filled a gap that had long waited to be suitably filled. Not only were the children's carriages of former times (made on four wheels, and to be drawn instead of pushed) hateful to most servants that had to draw them, but they were the cause of occasional ill-feeling between children's nurses and their employers. "The perambulator," fortunately, was invented, and restored harmony. They not only are light and convenient little carriages, and, if well made, durable, but (with ordinary precautions) almost indispensable to the parents, nurses, and children of the rising generation.

GEORGE N. HOOPER, *Reporter.*

#### RULE FOR TAKING CROSS-MEASUREMENTS ON THE CANT-BOARD.

THE rule we now give for taking cross-measurements on the cant-board has been sometime in use in England, and will prove very useful to the trade in this country. By it much unnecessary trouble and risk of mistakes will be avoided.

This rule, as seen in the engraving, begins with the narrowest cross-measurement, and is numbered onward to the widest, on a scale of one half-inch. It has a sliding-shoulder at the end where the figures are highest, and is adjusted to each particular body by letting the figure which represents its greatest width rest on that point in the side sweep line, and then setting the shoulder to the straight edge of the board; when the shoulder is fixed,

the rule can be held to the narrower parts, and, being marked on a half-scale, doubles the contraction, and subtracts it from the greatest width.

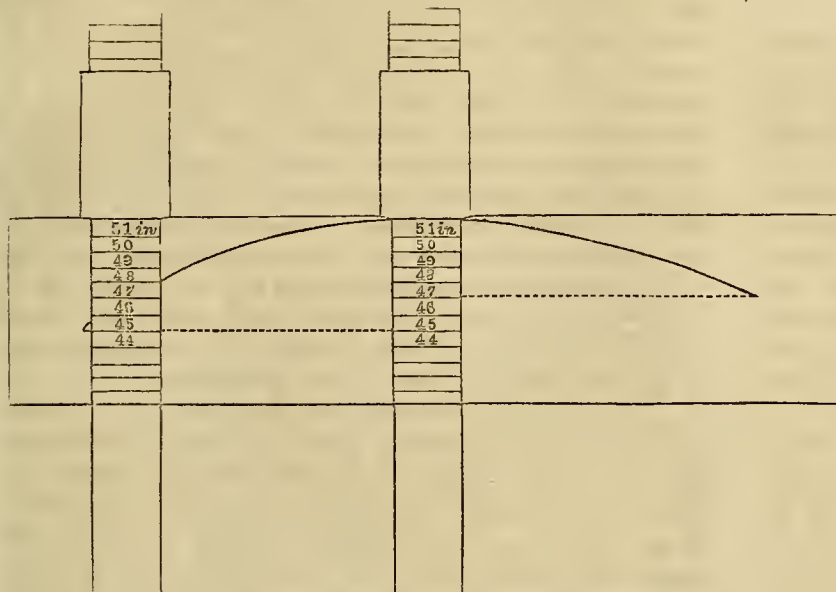

In connection with the above, it is proper to remark that the practice of representing the turn-under of the body by one unbroken sweep, is very perplexing to the learner, and of little use to any one. It is only useful for a plain coach; but with the French Brougham, where the bottom-side line, from a distance of about 13 in. from the elbow at the short bottom-side, suddenly descends to a distance of perhaps 23 in., it is evidently of little benefit. A more simple method would be to take the turn-under of the principal points of the body, on the turn-under pattern, at their respective distances from the elbow, and then to mark it off from the side sweep line on the board at the corresponding points; by which means the timber can be got out to one sixteenth of an inch, and scarcely a shaving need afterwards be taken off when "sweeping-in."

### BEDDING FOR HORSES.

BY S. EDWARDS TODD, ESQ.

HORSES, as a general rule, lie down to rest but a few hours in a day of twenty-four, and a great many horses do not lie down at all for several successive days and nights; and many horses that would lie down for a few hours during the night will not, because they know that they will not have a comfortable bed. If manure is allowed to accumulate in a stall for a number of days, a horse will soon learn that he cannot rest comfortably on such a heap, where he cannot lie in an easy position; therefore, he will often stand until he becomes very tired before he takes any rest.

Horses do not require as much time to rest, while in a recumbent posture, as horned cattle. For this reason their beds should be in good order, so that, when they do lie down, they may rest and recruit for the labors of the ensuing day.

Great care should be exercised, in making beds for horses, that the straw be not left in large rolls, or wads, which will cause them to lie very uncomfortably. Bedding should always be as *short* as practicable, that they

may not roll it up in bunches. Therefore, chaff is better than straw, providing it is not full of awns or beards. For bedding mares, chaff having beards in it would not be objectionable; but, for geldings, wheat or barley chaff having beards in it would be a dangerous kind of bedding, because the long, stiff and harsh awns would be very liable to enter the sheath, and cause inflammation and death. Sawdust, turning-shavings and shavings from planing-machines make first-rate bedding; because such substances are very short, and will not roll up in wads, and will also absorb much of the liquid of a stable—thus making a valuable manure.

Horses seldom lie down during the day-time while in a stable, unless everything about them is very quiet. For this reason, the bedding should all be well shook up at night, removing all the manure, and making the bed as comfortable as possible. Let each animal have an abundance of straw to lie on, and, instead of simply sprinkling the floor with it, cover the entire stall not less than one foot thick, shaken up lightly. A bed thus made any horse will enjoy, especially in cold weather. Do not be afraid of getting a little too much straw beneath a horse, as it will not be lost.

### Home Circle.

#### NIAGARA RIVER, FROM GOAT ISLAND.

BY ANNIE M. BEACH.

O, LET us not speak in this beautiful place;  
Let us look on the river, the soft azure sky,  
And list to the song of the sun-gilded waves,  
In sweetness forever still murmuring by.

O beautiful River! what sights hast thou seen  
In the unnumbered years of the dim long-ago?  
I hear in thy music a voice from the past,  
A mingling of joy and a mingling of woe.

There are names carven deep on the old forest trees,  
But the dates are worn out by the fingers of Time.  
This only we know: they once wandered, as we,  
To the sound of thy ceaseless and musical chime.

They gazed on the scene which we gaze on to-day;  
They heard in these branches the breezes' low sigh;  
They passed, as we, too, shall soon pass, from the Earth  
To the "City of Silence," *forgotten for aye.*

O beautiful River! when far from thy shore,  
In dreams my wild fancy will wander away  
To gaze once again on thy peace pictured face,  
In the palace of Memory hidden away.

O, thanks to the Giver of all that is good  
For the music and sunshine around and above,  
And the gift of sweet Memory's magical spell,  
Which holds in its keeping the scenes that we love.

CAMBRIA, Niagara Co., N. Y.

## MRS. MAYWEED'S AUCTION SALE.

BY H. LOUISA CRANE.

PERMIT me, before proceeding to detail the facts which form the subject of my present document, to give you a particular introduction to my heroine, Mrs. Mayweed, for she being one of Nature's odd gifts, your imagination would probably fail to do her justice. In person, then, she is rather tall, and very erect; her eyes are black and piercing, and her hair, that formerly rivaled in hue the raven's wing, is now slightly intermingled with grey; this she usually wears arranged in a "frize" on each side of her face, which, together with a brilliant set of false teeth, not a little adds to the charms of a face never, perhaps, designed to be beautiful, but still far from ill-looking.

Mentally, Mrs. Mayweed is a lady of respectable talents, but which, like the diamond in its rough state, would be improved by polishing. Accomplished, rather than educated, she once might have boasted of being no contemptible musician; but, as the unused key is apt to rust, that talent, little by little, vanished, and her musical fame has gradually vanished. She still asserts, however, that in her youth she was not without fine vocal powers, although, if judged of from present specimens, she would be found destitute of many of the qualities that distinguish a vocalist, and that sweet voice which once elicited so many still-treasured compliments now vibrates uncertainly between *flats* and *sharps*, but seldom sounds a *natural*.

For the last fourteen years, Mrs. Mayweed has occupied the dwelling wherein she now resides, and fourteen (long or short) years she considers a very long period for any person to spend in superintending a house which, notwithstanding her extra good management, has now become perfectly uncontrollable. Her servants are "spunky," and, on the least provocation, leave without a moment's notice; her landlord is unreasonable, and all things wear a most discouraging aspect. Being withal a little nervous, she has become almost distracted by this untoward state of affairs, and, some few months since, came suddenly to the *desperate* conclusion to break up housekeeping, dispose of her furniture, and go to board.

But now a difficulty presented itself. How was this furniture to be disposed of? Should it be stored, given away, or sold? And, as the first step towards solving so intricate a problem, she concluded to take a general survey of her dominions, and discover, if possible, in what her household wealth consisted. Most satisfactory was the appearance of all things until her arrival in the attic, where she found herself completely confounded by piles of furniture—maimed, broken, and imperfect. The quantity was too great for storage, the articles too useless to be acceptable to her friends and fit only for public sale.

The point thus decided, for many a week the contemplation of "an auction" engrossed her every thought; and, when it was finally proclaimed as a settled fact, it had a similar effect upon the minds of the whole household, which forthwith became a scene of "confusion worse confounded."

The week preceding the day of sale was one never to be forgotten by the inmates of Mrs. Mayweed's house—scrubbing, scouring and polishing were the only occupations. Every article, from the most venerable relic of

antiquity to the most modern specimen of art, was made to appear in its best, so as to command the highest possible price. The carpets were variously dealt with, for, after having been shaken until a repetition of the act would probably have been dangerous, magnesia and turpentine were applied in such quantities, to extract the spots of oil, &c., &c., that they were obliged to remain dormant in a solitary corner for several days. Curtains were dusted, old chairs and tables repaired, mahogany polished, odds and ends of crockery sorted, and many an article which had remained in the same station since the last periodical cleaning was now brought forth from its hidden recess, to be ranked among the valuables. Quite a number, it is true, were past being useful, and would probably remain on hand; but, as they would fill a line in the catalogue, they were quite important.

This week of confusion was one not to be envied. Everything had undergone a complete metamorphosis from the attic to the cellar, and it really seemed that one required patience equaling that of Job to endure the tumult of the present time. Imagination will give a better idea of the scene than description. Imagine yourself, then, seated at the breakfast-table, with a white cup and blue saucer, a broken plate, a one-tined fork, and a dessert-spoon at your service, and you have a slight idea of the *table fare*. But sleep, that restorative to all human ills, was also to be provided for. At first, chairs were substituted for bedsteads; but, by and by, in the general fever for repairing, chairs became so scarce that it was with the greatest difficulty four of similar height and dimensions could be found to supply the deficiency. The furniture was arranged and rearranged until Mrs. Mayweed thought all would appear to the best advantage; the prices were fixed upon each article, and all being in readiness, the eventful day arrived.

The morning sun shone brightly on the bright red flag displayed from the second story of the dwelling, and, by ten o'clock, the throng had assembled. Persons, both *native* and *foreign*, and of all classes and trades, were among the gathering. The windows were low, and it was quite an edifying sight to look in at them. Now and then the *head* and *phiz* of some person on tiptoe would be elevated above the rest, to catch a glimpse of what was going forward, while one extremely tall person was continually molested with the request that he would take off his hat or stoop a little lower, that others might have a chance.

Scattered in lavish profusion were pamphlets, setting forth all articles to be disposed of, in every corner and crevice of the house. But now a stentorian voice, and the sound of two hands struck vigorously against each other, called the attention of the anxious Mrs. Mayweed to the quarter from whence the sound proceeded, where the portly individual who was to officiate as auctioneer stood, mounted upon her *best table*, with nothing but a piece of baize between his shoes and the mahogany—that table which she had so carefully cleaned and polished, to be used in such a manner!—it was shameful.

Proceedings began in the kitchen. The first article offered for sale was a brightly scoured Dutch oven, which, to the horror and consternation of Mrs. Mayweed, was knocked down for two and sixpence, though she positively asserts that, not two months previous, she paid fourteen shillings for the said article, and, in the excitement, she audibly proclaimed, to "all whom it might concern," that

it *should not* be sold for two and six-pence; but her resolution was of no avail. The new and modern cooking-stove, for which only a short time since she had given \$35, went for ten, merely because the soapstone was somewhat damaged, and everything else was sold at the same ruinous rates.

The crowd was now becoming somewhat excited—*particularly* the female portion—as the auctioneer dwelt upon the merit and value of each separate article, and he was at last obliged positively to forbid the “dear ladies” bidding against themselves—a practice so general among these anxious speculators. While he still continued to shout forth that everything was “going at a remarkably low price, and all should purchase while such an excellent opportunity presented itself,” Mrs. Mayweed sat anxiously watching the proceedings, and gazed with sadness as, one by one, the different articles passed to their new owners. Bureaus, tables, chairs, curtains, carpets, pictures, &c., were cast aside with the fatal word “Gone!” And now the auctioneer was dwelling with much eloquence on the elegance and exquisite beauty of a pier-glass, which he declared to be the most desirable as well as indispensable article in any household. “What will you give for this?” cried he. “Only fifty dollars! I’d give sixty myself. Five more is bid—a lady bids sixty—sixty dollars by two bidders—seventy—eighty—going at eighty—going at this ruinous rate—is ninety bid?—ninety dollars—going at ninety dollars—once, twice, thr—.” Just at this critical moment an aristocratic looking gentleman, casting his eyes on the beautiful mirror, offered *one hundred dollars*. “Going for *only* one hundred dollars—who’ll give me ten?—*only* one hundred dollars—g-o-i-n-g, g-o-i-n-g, gone!” and down came the uplifted hand, and the expression “sold!” Then the keen-eyed crier raised both hands in dismay at the “perfect sacrifice” he had made in its sale, although he well knew the price was as great as a new one would command in Broadway.

Thus matters continued for the lapse of an hour or two, when, the sale being complete, the multitude began to disperse, the purchasers only tarrying long enough to settle their bills and give the necessary orders respecting their new property. Spring-carts and cartmen were soon on the spot, and now the out-door bustle began. Mrs. Mayweed was (as it were) flying around with all imaginable speed, to see if the articles intended for herself were properly guarded; but, notwithstanding her extra guardianship over them, there were several mistakes made. One entirely inoffensive person having nicely stored his purchases, was about dispatching the cartman with the burthen, when the affrighted lady herself appeared, declaring that “*that* mahogany table was her own, and that she never intended to part with it; it had been in the “Old Homestead” a long time, and should descend to her nieces and nephews to the last generation—therefore, she commanded it should be directly taken off that cart.” The surprised purchaser, rather than be seen quarreling with a lady in the street, consented. The affair was settled with becoming gallantry, and the table left upon the sidewalk.

The various articles, with the respective purchasers, having now taken their departure, the house was left vacant, and that night the household furniture of Mrs. Mayweed was widely separated, some having taken passage in ferry-boats, some in the railroad cars and common carts, and a small proportion by the hands of pedestrians.

Thus the contents of this “well-regulated house” were disposed of, with a profit on some articles and a decided loss on others. And thus concludes my somewhat extended account of this memorable transfer of property—unsatisfactory to Mrs. Mayweed, as she positively avers—but, my private opinion is, that when the gluing and polishing of some of these “gems” have passed away, the *purchasers* will have the most cause for regretting their predilections for “auction bargains in furniture.”

## Pen Illustrations of the Drafts.

### BELGIAN CALÈCHE.

*Illustrated on Plate V.*

THIS very unique design we transfer to our columns from the *Mercurè Universel*. It represents a Caleche sent from Belgium to the late International Exhibition, but is not among those to which a medal was awarded. There are some beautiful lines in this body, but we are apprehensive that the front quarter looks better on paper than it does carried out in construction. Tastes differ, however, and we leave our readers to form their own judgment in this matter.

### SINGLE-HORSE COUPÉ.

*Illustrated on Plate VI.*

THE Coupé has now become one of our most fashionable carriages, as any one may see who strolls along the Fifth Avenue about 11 o'clock A. M., where, in that aristocratic thoroughfare and its tributary streets, he will find them thickly standing, with a liveried servant, drawn up before the door; or at a later hour visits Stewart's marble palace, where the *bon ton* do their shopping. They are fast taking the places of coaches among the “upper ten,” being much lighter and better accommodated to the ordinary use of the ladies.

Through the kindness of Messrs. Brewster & Baldwin, of Broadway, we are enabled to present our friends with a drawing of a Coupé, light enough for one horse, of the latest type, and, as we think, a very pretty one. The bodies of these vehicles are painted of various colors, such as black, blue and brown-blue predominating, and are striped with broad gold-imitation stripe and lined with blue or other colored Terry, and the mountings silver.

### HALF-CUT-UNDER PHAETON.

*Illustrated on Plate VII.*

MR. EDITOR:—The chief peculiarity of this style of body lies in the “cut-out,” which is formed by putting in a very wide bottom-side, and cutting into it 3 or 4 inches, and then boxing around the recess with either carved panels or imitation blinds, which will have a very pleasing effect. The seats in this example may be shifted so as to bring the back one to take the place of the front, and *vice versa*, when desirable.

x. z.

This original design, contributed by a new and valued friend, is the first of a series with which we hope to treat

the patrons of this Magazine during the year. In our next they will have a four-in-hand Phaeton from the same artist, drawn expressly for us.

ROUND-CORNERED BUGGY.

Illustrated on Plate VIII.

As we have elsewhere observed, there is not much new in the style of buggies; but the one given on this

Plate is about as popular as any. It is intended to represent a *round cornered square body*, if we may be allowed such a term. Our engraver has given the corners a little too much rounding; with this exception the illustration is a very fair representation of a fashionable New York buggy. See further remarks on "Fashions in Buggies" on page 30.

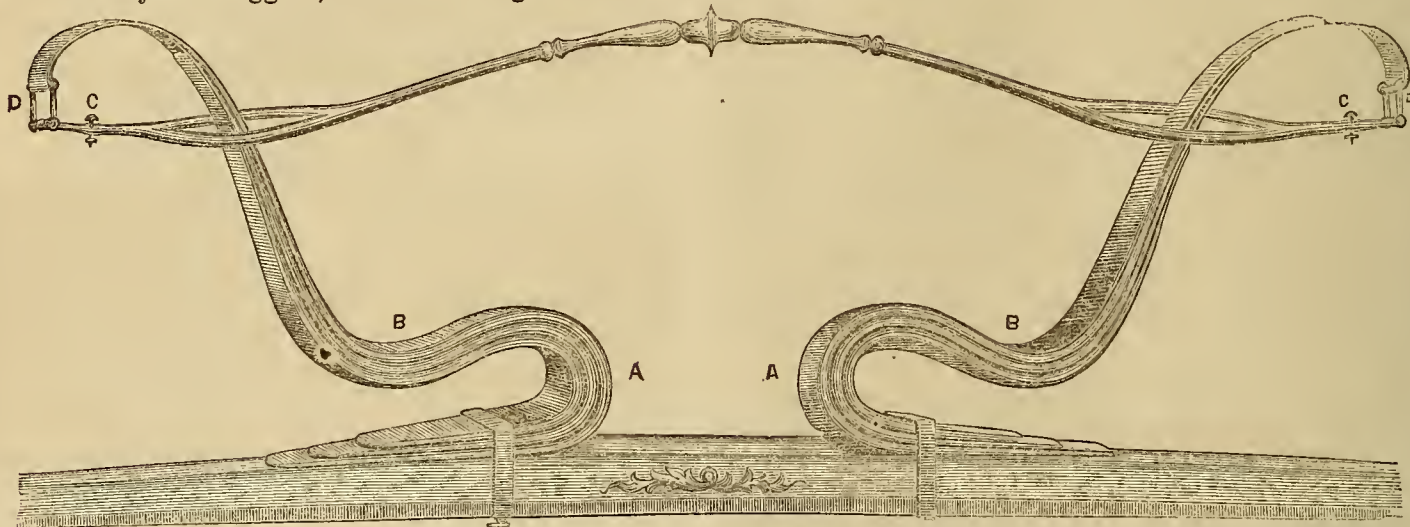

Sparks from the Anvil.

SELF-ADJUSTING CARRIAGE SPRINGS.

THREE years ago this spring was patented by J. M. Forrest, of New York. The advantages claimed for them are, that only about one-half the weight of steel is required to that of elliptic springs, making the first cost less; that as there are neither welds nor holes in them, they are less liable to break; and that with a simple machine they are more easily made than the ordinary spring. They are called *self-adjusting* because, with a light weight, they spring the entire length, and are not so stiff as when a sufficient load requiring a stiff spring closes them under the point B, as represented in the cut, Fig. 1. The joint at D, renders them submissive, thereby preventing that sudden shaking or jolting which passengers are subjected to by other springs whilst passing over uneven roads,—the motion being very easy and pleasant. The cross-bar represented in the large engraving may be dispensed with, but when the collar is plated it is considered to be ornamental.

When this cross-bar is omitted the ends of the loop-irons to the carriage-body are attached to the spring as in Fig. 2, at X. The body-loops of the carriage when attached to the cross-bar are fastened by a bolt at c, in Fig. 1, and instead of the entire weight of the carriage being placed on the center of the axle, as with the elliptic spring, it is divided, pressing at each end on the axle and pulling-up in the center, making the axle much less liable to break. Persons wishing to purchase county or shop rights in

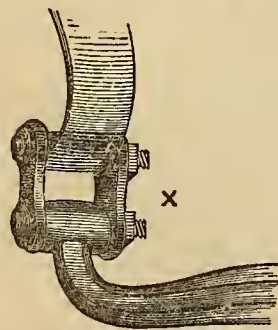

either Albany or Rensselaer Counties, New York, can address Henry Holton, 32 John Street, New York City.

NEW APPLICATION OF THE C-SPRING.

SOME novel features in the construction of carriages were shown in the late London Exhibition. Among these was an inverted C-spring with leather braces, as illustrated in our engraving. They are the invention of

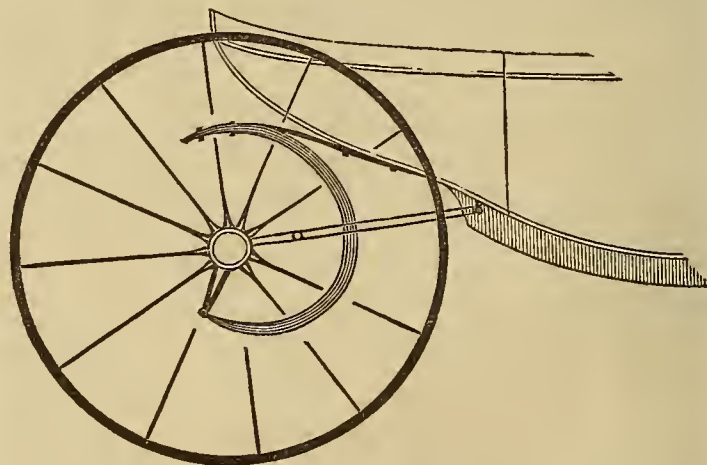

Corben & Sons, of Great Queen Street, London, and are introduced as an effectual remedy for the hard motion and drumming noise complained of in carriages hung upon elliptic springs, and are said to answer the purpose well. The materials used are leather and steel, and the spring may be applied to almost any kind of carriage, and the costs are but little more than that of the elliptic spring, and not much heavier. In this instance these springs were applied to a diorpha, the back quarter of which figures in our illustration.

THE LONDON MECHANICS' MAGAZINE ON YANKEES. —The journal we have mentioned winds up a lengthy notice of the American patent cow-milker in the late International Exhibition with the following *compliment*: "To a 'cute Yankee' the Goddess of Science, herself, is but a good big cow with plenty of milk."



## Paint Room.

### COMPOSITION OF PAINTS.

BY H. HARPER.

The nature of paints—Their effects on oils in retarding or causing the decay of the same, and the liabilities of poison from paints when by the perishing of the oil they are loosened from the substances on which they have been spread—The fatal effects of white-lead on animals—The dangers we suffer from living among paints.

WE do not propose in connection with this subject to enter into all the minute operations necessary to the manufacturer of paints, or anything of the kind, more than is necessary to give the painter a knowledge of the component parts of the substances that he is daily using, and the effect which different paints have in destroying the cohesive qualities of the oils and gums with which they are held to the surface of the things painted; but to show that when the cohesive nature of paints is destroyed there is greater liability of poison from some kinds than others.

Paints are mostly produced from mineral substances, such as iron, lead, zinc, copper, arsenic, &c., which are reduced from their hard and firm mineral state by oxygen, carbon, or some of the acids, into the fine powder which is so soft that we can grind it into paste that may be spread over the surface of work, forming a beautiful finish to the same. It must be remembered that these same gases which decomposed the solid metal still pervade the atmosphere that surrounds the paints, and which has once more become a solid substance by the process of hardening—a liquid oil,—and that this same gas will continue to operate in the same way, upon this second solid paint, that it did on the first solid metal, rendering it back the second time into the same fine powder, but which has now been mixed with oil.

Experience teaches the practical painter that these gases operate with more effect on some kinds of paints than on others, and, if he knows the composition of the paint—whether it has been reduced from its solid state by carbon or oxygen—then, by experience he will learn to distinguish the quick-decaying from the long-lasting paint. A perfect knowledge of chemistry would help the investigator materially; yet it would hardly compensate for a lack of practical knowledge of the uses of paints. It is the misfortune of this branch of business that the two qualifications are not often found united in the same person.

Paints that have been made by reducing the solid substances with either carbon, or oxygen, so that they are nearly a pure carbonate, or oxyd, would seem to be the most lasting paint; and also the paint that has the least effect in drying the oil with which they are mixed. In the composition of such paints with oil, we have to introduce another substance which is undergoing the process of oxydizing, to make the oil dry; and this establishes pretty certainly the conclusion, that while oxygen is necessary for drying oil, the same thing causes decay while it is undergoing the process. This may be seen in the use of lamp-black and venetian red; the first is almost a pure carbon of vegetable substance, and the other a pure oxyd of iron, mixed more or less with clay, or marl, which has no affinity for oxygen. These two paints are,

when mixed with oil, the most lasting and at the same time the least susceptible of giving the oil a drying quality. We have to introduce another substance to make the oil dry when we use this paint, and every painter who observes any thing about his trade must have noticed that, as he increases his dryer, he renders his paint the less lasting where it is exposed to the atmosphere. He will observe the same in the use of varnish; the quick drying is the least lasting. From this we must infer that when a solid substance has been perfectly destroyed by oxygen or carbon and made into paint for use, that neither of the two gases has any more affinity for the paint, and not as much for the oil with which it is mixed, which accounts for the lasting quality of the same.

White-lead is made by exposing thin plates of the metal to the action of vinegar vapor, which causes the metal to absorb carbon, and which transforms it to a white powder, and which, when pure, takes the name of Flake-white. A mixture of this flake-white and barytes forms the white-lead for painters' use, the purity of which depends on the relative quantity used of the two articles, the barytes being the cheapest of the two. It comes from the factory marked "pure," "extra," and various other brands by which the painter who is well posted can form a tolerable good guess about what he is using as compared with the best quality. The idea of marking it "pure" is an absurd one, and shows how little reliance can be placed on such marks. Originally, when lead was mixed with whiting, in England, the relative quantities were fixed by statute to be one-eighth of whiting, and that mixture would command from two to three cents more on the pound than American lead, which had no statutory restrictions, but was called "pure."

White-lead is considered valuable on account of the body which it gives to paint, and is much used for various purposes; for the first coats on carriage-parts particularly. It forms a good body, has a good drying tendency, and pure white appearance, which makes it valuable for mixing colors with; yet it should be banished from use where the decay of oil allows it to fall off, on account of its poisonous qualities. The poison has been supposed to affect the painter only, but this is a great mistake. There are very few bad effects that he derives from lead, alone, in the present form in which it is used. The bad effects are these: it goes into the hands of those who are ignorant of its nature, and who use no discretion in its use; and they are as liable to put it on to a place when the oxygen of the atmosphere will destroy the oil and leave a fine powder of poison loose, and where it is, by accident, in some way liable to be introduced into the stomachs of those who are in the vicinity. A case of poisoning came under my own observation which I will relate to show one of the various forms in which it is injurious.

A man by the name of Martin was engaged in hauling goods from Milwaukee to Berlin, Wisconsin, a distance of about 100 miles. At one time he brought home 25-pound kegs of lead with other things, and, after discharging his load at the store, he drove his team into his own barn-yard, when he took a small quantity of hay that had been in the bottom of his wagon and threw it out for his cattle, that were in the yard, to eat. He observed at the time that some of the lead had oozed out, between the staves of the kegs, on to the hay, and also knew that it was poisonous, but did not think it was enough to hurt any body. The next day he made the discovery that

seven of his cows were sick, and he also remembered that they were the only ones of his stock that had partaken of the hay. This led him to think that they were poisoned with the lead. He administered such antidotes to the poison as were recommended, without any effect towards curing them; in a few days after they were all dead. There are but very few cases where we can trace poisoning from lead back to the real cause; but to one who knows that thousands of pounds of deadly poison is spread out on the houses of every village and city, and that the same is becoming loosened every day, such will be apt to conclude that much injury to health must arise therefrom.

The great mistake with those who understand the nature of lead, and other poisonous paints, is, that they do not make an allowance for its coming off after once being spread on wood with oil. This must be the case sooner or later where it is exposed to the action of the atmosphere and wet, from the simple oxydizing of the oil; therefore we would say, to those who will not discard it entirely, use it with the utmost caution.

(To be continued.)

### Trimming Room.

#### LININGS FOR A BOARD SEAT.

THE accompanying engraving shows the manner of lining the board seat (turn-over seat) of a buggy, illus-

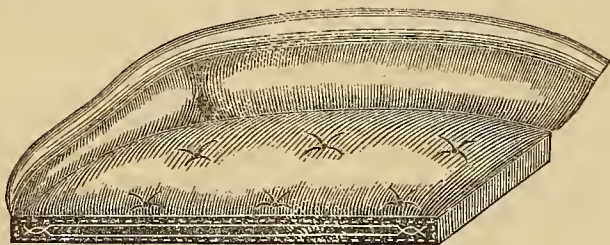

trated on Plate XI. of this Vol. The material in this instance is supposed to be brown morocco, with a roll around the top, and a heavy underlaid seam between the upper and lower rolls, the cushion being single and extending the entire length of the seat.

#### ENAMELED CLOTH.

THE black enameled cloth is the kind most largely in use; but the method of making the different colors is essentially the same, the black being the foundation, and the colors afterward applied by hand. The basis of the black is cotton cloth of the best quality, made expressly for the purpose. It varies in texture and width, according to the kind of goods for which it is intended, the width being from thirty-four to fifty-four inches. The cloth is taken from the bale and wound upon a large iron cylinder, in which position it is ready to receive the first coat, by being slowly passed through the machine across and between the huge iron cylinders, from the smaller of which, at the top, it receives the first coating of composition—a mixture of oil, lamp-black, rosin, and other ingredients, boiled together till about the consistency of melted tar. From between the cylinders, dressed in its black coat, the cloth is carried to the story above through an aperture in the floor, and wound upon a huge wooden frame, resem-

bling, in shape, the old-fashioned reel. By an arrangement of spokes upon the arms of this huge wheel, each layer of cloth is kept separate, so that no two portions of the cloth will come in contact. The frame, with its contents, when filled, is passed into what is called the heater, an apartment kept at a high temperature, for the purpose of drying-in the coating of composition. After remaining in the heater a sufficient time to complete the drying process, it is removed to the lower story whence it originally started, to pass through the hands of workmen, who make all the rough places smooth. It is laid on long tables and alternately sprinkled with water and rubbed with pumice-stone till the whole surface is made perfectly smooth. The cloth is then wound upon the cylinder again, as at first, and passed through the machine in the upper story, upon the huge reels, and into the heater, and again under the pumice-stone. The cloth is passed through the machine five times, or till the required thickness has been laid on. After the last scrubbing down, the fabric is taken to another department in the upper story, thoroughly varnished, and again passed through the heater. It is now a piece of cotton cloth, with a thick, shining coat of black, very much resembling patent leather. But it has not yet received its leather finish; so, in another department, it is passed through the enamel machine, which consists of another set of huge rollers, one of which covers its surface with irregular indentations resembling the grain of leather.—*Technologist.*

### Editor's Work-bench.

#### THE SITUATION.

THE above heading greets us when we look into the daily newspaper, and when we read on we find it introductory to an attempt to tell how the war progresses. Our individual *war* against the printers and paper manufacturers places us in a "situation" from which we would gladly escape without calling in the aid of our friends, could we do so without loss; but, as we intimated in our last number, we have since been obliged to advance the price of this Magazine to \$4 for the Fifth Volume—12 numbers, embracing the period of seventeen months in their issue—and even at this price see no prospect of making any money as long as the war lasts. We have looked in vain for a decline in the cost of paper for the past two months; we can therefore expect no relief, other than in charging more for our publication. Relatively \$4 is not as much as \$3 was formerly, and it is not a greater advance than the carriage-maker gets for his work over last year's prices. We therefore hope our friends will not forsake us in these times of trial, but cheerfully stand by us; and we promise that as soon as times permit we will again reduce the subscription price to \$3. Those who subscribed during January and have not yet sent in the \$3 will please to do so at once. Should they not heed this notice they must not complain if, after the 1st of April, we call on them for \$4.

## ENGLISH VANDALISM.

In this number we give the remainder of the Committee's Report of Carriages in the London International Exhibition for 1862, in which full justice has been awarded to American skill; but there is a sequel to the report, which, in all probability, will never find a reporter on the other side of the Atlantic. It will be remembered by those familiar with our pages, that there were only two vehicles sent from this country to the recent exhibition, both of which were the contributions of Messrs. Brewster & Co., of Broome Street, New York, and that the Phaeton was awarded the first premium of the Royal Commission, for good workmanship, good material, &c., all of which was very satisfactory to our friends and pleasing to our national vanity.

Scarcely had this pleasing intelligence reached these shores, when we were privately told that both the vehicles referred to had been shockingly mutilated, as is supposed, at the hands of jealous English operatives. After the strong evidence manifested by the jurors, that they were uninfluenced by any national prejudice against us in their decision, it was difficult to believe that any class of men could so far divest themselves of manhood as to commit such an outrage against those who had thus confidently intrusted property within their reach. Supposing there might be some mistake in the matter, we have deferred alluding to the subject until now; but facts are stubborn things and not easily suppressed, and our worst fears have been painfully realized. We say painfully, because we consider it disgraceful to the craft, in any clime, to act in such a manner as that complained of. This conduct, extended, would carry us back to the dark ages when to mount a "palfrey" was the acme of travel.

What could have been the motive for this vandalism, is a matter difficult to determine; but the supposition is that a prejudice against machine labor, which is known to be inherent in the minds of ignorant English operatives, had something to do with this outrage. If such is the case, they have had only the disgrace for their reward, for we are assured that the stitching in this instance was done by the hand—the careful labor of several days. We learn that both carriages had been disposed of to English customers, to be delivered to them when the Exhibition closed; but three days previous to that period it was discovered that both dashes and all the fronts of the cushions and some portions of the panels also were cut; the leather work through and through, apparently with a knife, so deep as to penetrate the apron rolled up against the dash. These were not simple cuts, but were crossed in every direction, showing evident vindictiveness in the mind which directed the hand in this operation.

Under other circumstances, this outrage against friendly exhibitors would have thrown the vehicles back upon the manufacturers, but the purchaser, in this instance, was so

honorable as to stick to his contract, after the Messrs. Peters & Sons, of London, had put them in complete order again. This extra expense should never have been entailed upon the manufacturers, to the lasting disgrace of *somebody*. We submit that such treatment as our carriages have received at the hands of Englishmen is not the best calculated for encouraging further contributions of the kind from this country, but is about what we might have expected.

## FASHIONS IN BUGGIES.

As to the general fashion in buggies this spring, there is very little new to report. Those who have our Fourth Volume to refer to will find, on Plates VIII., XXXIII., and III. of the present Volume, a fair exhibit of the present New York styles. These are now mostly painted black, and striped with gold or its imitation, by a quarter-inch stripe, or else are painted lake and striped with red. The material for the lining is mostly blue cloth, with leather weltings substituted for narrow laces, the general features of which are exhibited in the drawing on page 11 of our last number. The price now ruling in New York for first-class top buggies is \$275, and for no-tops about \$185. To some of our country friends these prices may appear exorbitant. To such we can only say that, should they see the labor and count the cost of the material used, they would soon acknowledge that these prices barely pay the manufacturer. We fear that the trade generally do not actually know how much their carriages do cost them. In this connection we subjoin a letter, we have lately received, bearing upon this very subject, hoping that some one will respond to the writer:

NEW YORK, January 22d, 1863.

E. M. STRATTON, Esq.:—*Dear Sir*,—I have often thought that you might confer a great benefit on the manufacturer by calling his attention to the actual costs of his work. In my opinion there are but few who really know what they pay out in getting it up, and this fact has been brought to my mind with great force, in hearing of the prices at which the Coupé is sold in this city. How many of the readers of your Magazine know that this carriage costs nearly \$100 *more* than a Hack Coach, while it sells for \$100 less? I would like to see an estimate of the costs from some competent and practical man, with the percentage added for rent and other expenses, as well as the 3 per cent. war tax, which all go to increase the costs, to which add 15 per cent. in the shape of profit. I have reference, in this article, to first-class work only and such as is sold by our best city houses.

Yours very truly,

EXPERIENCE.

## ABANDONED INVENTIONS.

THERE are a great many suggestions made in relation to carriages, with a view to improvement, but which are abandoned before they ripen, either on account of their impracticability or from other causes. These it is our intention to chronicle for the study of the curious in such

matters, premising that under this head we include no patented articles, both in America or Europe.

A man in England thinks that an improvement may be made in shaft tugs by dividing the tug or bearer and hinging or jointing the same so as to allow of the shaft being easily placed in the tug or withdrawn therefrom, the tug being provided with a latch or bolt, of brass or other metal, forming a complete ring, which however need not be perfectly circular in form. This he prefers making of iron and covering it with leather, and then hinging one part of the tug to the other by a knuckle-hinge and securing the end by a spring latch, of brass or other metal, catching into a brass catch placed close to the buckle by which the tug is attached to the back band of the harness, having a loop or eye of metal for passing the back band through, thereby doing away with the necessity of passing the back band round the shaft.

Another inventor thinks an improvement might be made in omnibuses and other vehicles by constructing parts thereof double, so that the bottom, sides, and top may, when required, be drawn out, so as to afford increased accommodation. The ordinary omnibus is built to hold twelve persons, but this inventor proposes to make his hold twenty inside when required. The fore part of this carriage is to be immovable; but all the parts commencing just in front of the hind wheels, together with the hind wheels and axle, are capable of being drawn, say six feet from the fixed part, the space being occupied by duplicate parts, over which the parts of the carriage drawn out have been made to slide. This, it is suggested, may be applied to vans and other long-bodied carriages as well. Another suggestion is the constructing of the frames of omnibuses, trucks, and other carriages, of angle-iron, and in screwing, bolting, or riveting to the angle-iron, for forming parts of the framing, two other angle-irons, to which timber, the panels, and other required parts to complete the carriage, are screwed or otherwise secured; then the whole of the framing and skeleton of the carriage are framed of angle-iron and of two angle-irons with timber between them. This inventor is far behind the Yankee's India-rubber Omnibus, referred to on page 196, Vol. Four.

Mr. J. Offord, of London, thinks the wheels of carriages might be improved by making the hubs of wrought-iron, forged whole, and then bored and hardened, so as to avoid the necessity of an axle-box, and tapped so as to receive the spokes, which he would also have made of wrought-iron, or some other metal, and screw into the hub. In rimming the wheels he introduces a laminated principle of construction, by using wood, vulcanite, india-rubber, iron, and steel. He thinks, too, that the steps of carriages might be improved, and thereby made wider for the feet, and rendered self-acting and noiseless.

Mr. J. Rock proposes to improve common road carriages—*First*, by making a carriage with a movable, close,

or coach-head, interchangeable with two half-heads similar to those of a landau. The inventor makes the coach-head in the same way as that of the "dioropha" carriage, patented by him Nov. 9, 1850; and the landau half heads he constructs in the same way as the barouche-head of the "dioropha," so far as regards the framing, strengthening, and fastening of the parts which meet and rest upon the lower body of the carriage at the elbow-line. *Second*. In addition to the coach-heads and the landau-heads, he sometimes makes a third head of the kind usually made to a barouche, which head may be used in lieu of the other two; and he also makes a folding flap or flaps to the body, to the front seat, and doorway, also in the same way as a barouche. These barouche fittings and head may be used interchangeably with the landau-heads, in cases where the carriage is not fitted with a coach-head also. *Third*. In some cases he uses the hinder half of the landau-head in conjunction with the flap. When he so uses the half landau-head, he sometimes adds a movable side piece, which may be either of panel, leather, or glass, in suitable framing, and which may be also made to turn back on hinges or joints, and serve as a wing or mud-guard. *Fourth*. In order to give more light to the interior of the landau-head, he makes side lights in some or all of the four "quarters." These side lights he makes with or without detached frames, either hinged to the head or made movable, and he places them, when removed, in recesses formed for the purpose in the doors or some other part of the lower body. These side lights may be of any suitable shape, and the frames may be provided with glass, Venetian slats, or paneling of any kind. *Fifth*. In order to avoid the notch which usually appears in a landau-head at the junction of the standing-pillar, when thrown open, he makes the standing-pillar with a projection, and cuts away a corresponding portion of the door-pillar. He then carries the pillar-joint as near as possible to the inner edge of the door-pillar, and he makes such door-joint, with a knuckle, the whole breadth of the pillar, and sufficiently large to allow of the groove necessary for the glass frame or blind to work in, to be filed or otherwise cut out of it, without cutting into the rivet or center pin; or he makes the joint only of the breadth of the groove or grooves, and carries the pillar down at each side of it to form the rebates which confine the glass or blind; he strengthens these portions of the pillar, which must necessarily be thin, with metal if required. *Sixth*. This invention relates to the foundation of the various parts of carriages called transom-beds, spring-beds, horn-bars, futchels, splinter-bars, pump-handles, perches, and axle-tree beds, of plate-iron or steel, cut out or forged to such shapes as, when bent, to enclose or partly enclose a hollow, will form such beds and other parts of the usual or any required shape, with some parts larger than others, as are necessary for use as bearings and otherwise, or for symmetry.

## EDITORIAL CHIPS AND SHAVINGS.

A COMPREHENSIVE ANCIENT PATENT.—The specifications for some of our modern patents are thought to be very prolix and comprehensive, but the following, describing a patent for improvement in ship-building, taken out in England by Sir John Christopher Van Berg, in 1636, goes ahead of anything modern in that line, extending even to "an invencon whereby the smythe's bellows may bee made to blow without putting to any hand either to houlde or draw them," and "doing whatsoever things may need to be grinded, beaten, brused, grated, pestled, hammered, cut, hewn, hact, sawed, whetted, playned with tools, turned, winded, rowled, circulated, caste forthe, or evacuated. Alsoe instruments partly mathematicall, partly mechanicall, serveing for the accurate measuring of land or ground, and may alsoe in a certayne manner be ymployed to coaches, carts, waggons, or any other thinge that is moved from place to place thereby to knowe the exact distance and dispatch of theire mocon, likewise instruments of sounding and fathoming of any depthes whither of waters, or mynes, or any other depth, as alsoe to knowe any heighte above the ground. Alsoe invencons of a kinde of waggons, waynes, coaches, cartes, litters, wheelbarrows, packsaddles, and side saddles, better for ease, advantage, and proffitt than hitherto have beene vsed," &c. Sir John's "invencon," applicable to many "thinges" besides those enumerated above, beats "the perpetual motion" of modern inventors "out of sight," keeping sinking ships from sinking, and after being sunk bringing them up "agayne, though they be suncke eightie fathomes deepe!"

LAW OF THE ROAD.—A writer in the *American Agriculturist* gives, as a reason why our laws relating to the road should not be changed, "the difficulty of obtaining common consent; the existing laws to the contrary; the necessity of altering the construction of all one-horse sleighs [not all], the thills of which are now placed in accordance with the present manner of turning out." He is, however, in favor of the driver changing his seat to the left, that he may better keep his vehicle from collision. He gives an additional reason for this in the fact that the step upon carriages is on the left side, and if a lady is first handed in, the driver must crowd past her to his place on the right—not easily done in these crinoline times.

LONDON BY GAS-LIGHT.—An American visitor, who was out all night in London, says that "at seven in the evening the streets were all full of all sorts of people, excepting only the better classes, or best class, going home from the day's business. At eight these had all left the streets, perceptibly thinning the out-door population. At nine the carriages of the great and wealthy began to appear, which soon filled all the thoroughfares with splendid equipages, for the nobles and gentry were now going out to their evening parties. From ten to twelve there was a second lull in the excitement upon the sidewalks and pavements; but at one the great carriages began to return, and a continued whirl of them was then kept up until nearly or quite two o'clock. . . . At four in the morning he began to see the cabs of some early risers, or of drivers called to some very early engagement made the night before, rattling rather soberly along the highway as the first harbingers of the coming morning. These evidences of approaching day gradually increased

in number, with a little sprinkling of pedestrians, some with carpet sacks, others with nothing but their walking sticks, or umbrellas, till five o'clock, when the streets, lanes and alleys began to teem again with the jostling mass of cabs, omnibuses and vehicles of all descriptions, and at half past six the whole city seemed again to be out of doors."

SAFETY-SKID POETRY.—In the late International Exhibition appeared, from the pen of some countryman of Pope's, the following gem:

"And now the anthems of the wandering bard  
Swell o'er the name of W. Pompad;'  
'Neath a bushel long was light of science hid,  
But now the world-famed Patent Safety Skid  
Sheds the bright radiance far abroad,  
From 257 Blackfriar's Road" (!)

This "wandering bard" should have a reserved place in the Poet's Corner of Westminster Abbey, to perpetuate the "bright radiance" of his—poetry.

ONE RESPECTABLE CARRIAGE IN DIXIE.—The Chattanooga *Rebel* says that "the carriage which brought the President (Davis) to Murfreesboro was one of the most elegant in the Southern Confederacy, and may well be considered one of the trophies of the war. It was the last carriage brought from the [Chattanooga R. R.] Company's factory at Nashville prior to the advance of the Yankees, and has been carefully preserved by Col Cole ever since, who was determined to keep one respectable carriage for special occasions like this." The insinuation in the above quotation is not very complimentary to art in the South as it existed under the "peculiar institution" regime.

WESTERN TRAVEL IN OLDEN TIME.—A cotemporary says:—"A team of horses to a carriage in old times might make an average of thirty or forty miles a day, taking two weeks to go from New York to Pittsburgh, three to Columbus, four to Cincinnati, or six or even eight to Chicago or Springfield. The stage-coach which, with its relays of horses, made one hundred miles a day, did wonders; and the famous old wagons, drawn by six or eight huge horses, with a ton or thereabouts to each horse, were doing marvelously well to jog, snail-like, over from eight to fifteen miles a day on the average. Think of those teams occupying a full month or six weeks in conveying a load of merchandise from Philadelphia to Pittsburgh or Wheeling! Now a single black-headed locomotive easily, in forty hours or less, conveys from Philadelphia to Pittsburg as many tons of merchandise as thirty years ago required twenty-five Conestoga wagons and a hundred and fifty or sixty horses forty days. It is also stated as a fact, in reference to the pioneers of the Western Reserve, two settlers occupied ninety-two days in traveling from Canaan Four Corners, east of Albany, to Cleveland, in 1798.

THE PRAIRIE MOTOR.—A western editor says that the steam wagon alluded to on page 183, Volume Four, of this Magazine, and about which so much has been written, started from Nebraska City for Denver some time ago, and that it had progressed in three months just ten miles—a little over three miles a month. At this rate it will take sixteen years and eight months to make the trip to Denver. It is said it will not proceed farther until a well is dug every few miles to furnish water, and trees are set out to furnish the voracious wagon with provender.

## CURRENT PRICES FOR CARRIAGE MATERIALS.

NEW YORK, Feb. 10th, 1863.

Apron hooks and rings, per gross, \$1.25.  
 Axle-clips, according to length, per dozen, 50c., 63c., and 75c.  
 Axles, plain taper, from  $\frac{3}{4}$  to 1 in., \$5;  $1\frac{1}{2}$  in., \$6;  $1\frac{3}{4}$  in., \$6.50.  
 Do. case-hardened, half-patent, \$7; do. \$8; do. \$8.50.  
 Bands, plated rim, under 3 in., \$1.50; over 3 in., \$1.75.  
 Do. Mail patent, \$2.50.  
 Basket wood imitations, per foot, 75c.  
 ☞ When sent by express, \$2 for a lining board to a panel of 12 ft.  
 Bent poles, each \$1.  
 Do. rims, under  $1\frac{1}{2}$  in., \$1.75 per set; extra hickory, \$2.  
 Do. seat rails, 44c. each, or \$4.50 per doz.  
 Do. shafts, per pair, 75c.; bundles, \$4.50; extra, \$5.50.  
 Bows, per set, light, 75c.; heavy, \$1.  
 Bolts, Philadelphia, per gross, 10 per ct. discount off printed list.  
 Do. tire, 95c. a \$1.10, a \$1.80, according to size.  
 Buckram, per yard, 18c. a 28c.  
 Buckles, per gross, 88c. a \$1.25.  
 Burlap, per yard, 25c.  
 Buttons, japanned, per paper, 15c.; per gross, \$1.50.  
 Carriage-parts, buggy, carved, \$3.00.  
 Carpets, Brussels, per yard, \$2; velvet, \$1.75; oil-cloth, 44c. a 50c.  
 Castings, malleable iron, per lb, 12c.  
 Clip-kingbolts, each, 25c.  
 Cloths, body, \$2 a \$3.50; lining, \$2 a \$3.50. (See *Enameled*.)  
 ☞ A Union cloth, made expressly for carriages, and warranted not to fade, can be furnished for \$2 a \$2.25 per yard.  
 Cord, seaming, per lb, 25c.; netting, per yard, 5c.  
 Cotelines, per yard, \$3.50 a \$5.  
 Curtain frames, per dozen, \$1 a \$1.50.  
 Do. rollers, each, 75c. a \$1.  
 Dashes, buggy, \$1.75.  
 Door-handles, stiff, 50c. a 63c.; coach drop, per pair, \$2 a \$3.  
 Drugget, felt, \$1.62.  
 Enameled cloth, 4 qrs. wide, 90c.; 5 qrs., \$1.15; 50 in., \$1.50.  
 Felloe plates, wrought, per lb, all sizes, 14c.  
 Fringes, festoon, per piece, \$1.75; narrow, per yard,  $12\frac{1}{2}$ c.  
 ☞ For a buggy top two pieces are required, and sometimes three.  
 Do. bullion, per yard, 31c. a 37c.  
 Do. worsted carpet, per yard, 6c. a 10c.  
 Frogs, 38c. per pair, or \$1.63 per dozen.  
 Glue, per lb, 25c.  
 Hair, picked, per lb, 38c.; in the rope, 36c.  
 Hub-borers (Dole's) for light work, \$15; heavy, \$18 a \$20.  
 Hubs, light, morticed, \$1; unmorticed, 75c.—coach, morticed, \$1.50.  
 Japan, per gallon, \$4, and *advancing*.  
 Knobs, English, \$1.38 a \$1.50.  
 Laces, broad, silk, per yard, 55c. a 65c.; narrow,  $7\frac{1}{2}$ c. a 10c.  
 Do. broad, worsted, per yard, 25c. a 31c.  
 Lamps, coach, \$14 a 18.  
 Leather, dash, 21c.; slit do., 14c.; enameled top, 21c.; harness, per lb, 37 a 40c.; flap, per foot, 16c.  
 Linen, heavy, a new article for roofs of coaches, 70c. per yard.  
 Moguet,  $1\frac{1}{2}$  yards wide, per yard, \$5.  
 Moss, per bale, 10c.  
 Mouldings, plated, per foot, 12c.; lead, door, per piece, 30c.  
 Muslins, per yard, 25c. a 35c., and *advancing*.  
 Nails, lining, silver, per paper, 6c.; ivory, per gross, 25c.  
 Name-plates.  
 ☞ See advertisement under this head on 3d page of cover.  
 Oils, boiled per gallon, \$1.50.  
 Paints. We quote white lead, extra, \$3.25; Eng. pat. black, 25c.  
 Pekin cloth, per yard, \$2.  
 ☞ A very good article for inside coach linings.  
 Plushes, per yard, \$2.  
 Pole-crabs, silver, \$5 a \$6; tips, \$1.  
 Rubbing stone, per lb, 11c.  
 Screws, gimlet.  
 ☞ Add to manufacturer's printed lists 15 per ct.  
 Do. ivory headed, per dozen, 38c. per gross, \$4.  
 Sand paper, per ream, \$3.50.  
 Serims (for canvassing),  $11\frac{1}{2}$ c.,  $12\frac{1}{2}$ c.,  $13\frac{1}{2}$ c., according to quality.  
 Shaft-jacks (M. S. & S.'s), light, \$2.50; heavy, \$2.75.  
 Do. tips, extra plated, per pair, 31c.  
 Silk, curtain, per yard, \$1 a \$2.25.

Slat-irons, wrought, per pair, 55c.  
 Slides, ivory, white and black, per doz., \$6; bone, per doz., \$1.50;  
 No. 18, \$1.75 per doz.  
 Speaking tubes, each, \$4.50.  
 Spindles, seat, per 100, \$1.  
 Spring-bars, carved, per pair, \$1.  
 Springs, best temp. per lb, 20c.; black, 15c.  
 ☞ Two springs for a buggy weigh about 38 lbs.  
 Spokes, buggy, per set, \$3, or about 6c. each for all under  $1\frac{1}{2}$  in.  
 ☞ For extra hickory the charges are  $6\frac{1}{2}$ c. each.  
 Steel, Farist & Co.'s Homogeneous American, per lb, 16c.  
 Do. English Homogeneous, do. 20c.  
 Do. Compound tire, do. 7c.  
 Stump-joints, per dozen, \$1.25 a \$1.50.  
 Tacks, 5c. and upwards per paper.  
 Tassels, holder, per pair, 63c. a \$1; inside, per dozen, \$3; acorn trigger, per dozen, \$1.25 a \$1.50.  
 Terry, per yard, \$7.  
 Top-props, Tho. pat., per set, 35c.; plain, com., 35c.  
 ☞ The patent props, with silver-plated nuts, per set, 75c.  
 Tufts, ball, per gross, 50c.; common worsted, 12c. a 25c.  
 Thread, Marshall & Co.'s Machine, No. 432, \$2.40 per half lb; No. 532, \$2.75 do.; No. 632, \$3.50 do.  
 Turpentine, per gallon, \$3.50, and *advancing*.  
 Twine, tufting, per ball, 25c.  
 Varnishes (Amer.), crown coach-body, \$4.25; hard drying, \$4.50; nonpareil, \$5, and *advancing*.  
 Do. English, \$7 a \$7.75, with an upward tendency.  
 Webbing, per piece, 44c.  
 Whiffle-trees, coach, turned, each, 25c.; per dozen, \$2.50.  
 Whip-sockets, rubber, per dozen, \$7 a \$9; pat. leather, stitched, \$3.  
 Yokes, pole, each, \$1.  
 Yoke-tips, 50c. a 75c.

We intend to enlarge and correct this list monthly, so as to enable those who commission us to make their purchases to ascertain by computation about the amount they require to remit us. This should be done, if a large sum, by draft to our order in New York, or if small, in a registered letter to our address. We will furnish these goods at a reduction on large orders. None but cash orders filled, and where C. O. D. bills are forwarded with the goods by express, charges for collection must be added, which amount in ordinary cases to from 25c. to \$1, according to distances. All this may be saved by sending us the money with the order. Please read notice of "General Business Agency," on 3d page of the cover, in connection with the above.

## TO READERS AND CORRESPONDENTS.

BACK VOLUMES of this work will be sold, in numbers, for \$3; when bound, for \$3.50, to which, if sent by mail, 48 cents must be added to pre-pay postage; if two or more volumes are called for at one time, they can be had for \$3 each, or will be sent by express, at the purchasers' expense, at the same price. The subscription to the Fifth Volume, now in course of publication, will be (in consequence of the advance in paper and printing) four dollars, IN ADVANCE, for the twelve numbers; and these will be issued, in 1863 for Jan., March, May, July, Sept., Nov., Dec., and afterwards monthly until the close of the volume in May, 1864. Should the war end, and business again resume its natural channel, we intend to resume and publish monthly, as formerly, the Sixth Volume in June, 1864. Any of the old numbers can be had for 30 cents each; the new numbers will be 35 cents each. It will thus be seen that we give our friends the benefit of low prices for old stock, and we trust they will allow for the necessity which compels us to charge an advance on our present issues, for the reasons above stated, while the present exigencies continue.

COVERS, handsomely gilt, and ready for binding the numbers therein (which any binder will do for 35 cts.), can be had at this office for 54 cents. When mailed (the postage on which we prepay), 66 cents. Any volumes left with us will be bound for \$1 each in our uniform style. This advance is caused by the rise of book-binder's material.

AGENCY.—Our friend Mr. Henry Harper, who is traveling in the West, is authorized to take subscriptions for us, and receipt for moneys paid; and any contract he enters into concerning this Magazine will be honorably carried out by the Publisher. In Canada West, Messrs. McKinley, Cowles & Co., at St Catharines (dealers in carriage-hardware), will act as our local agents.



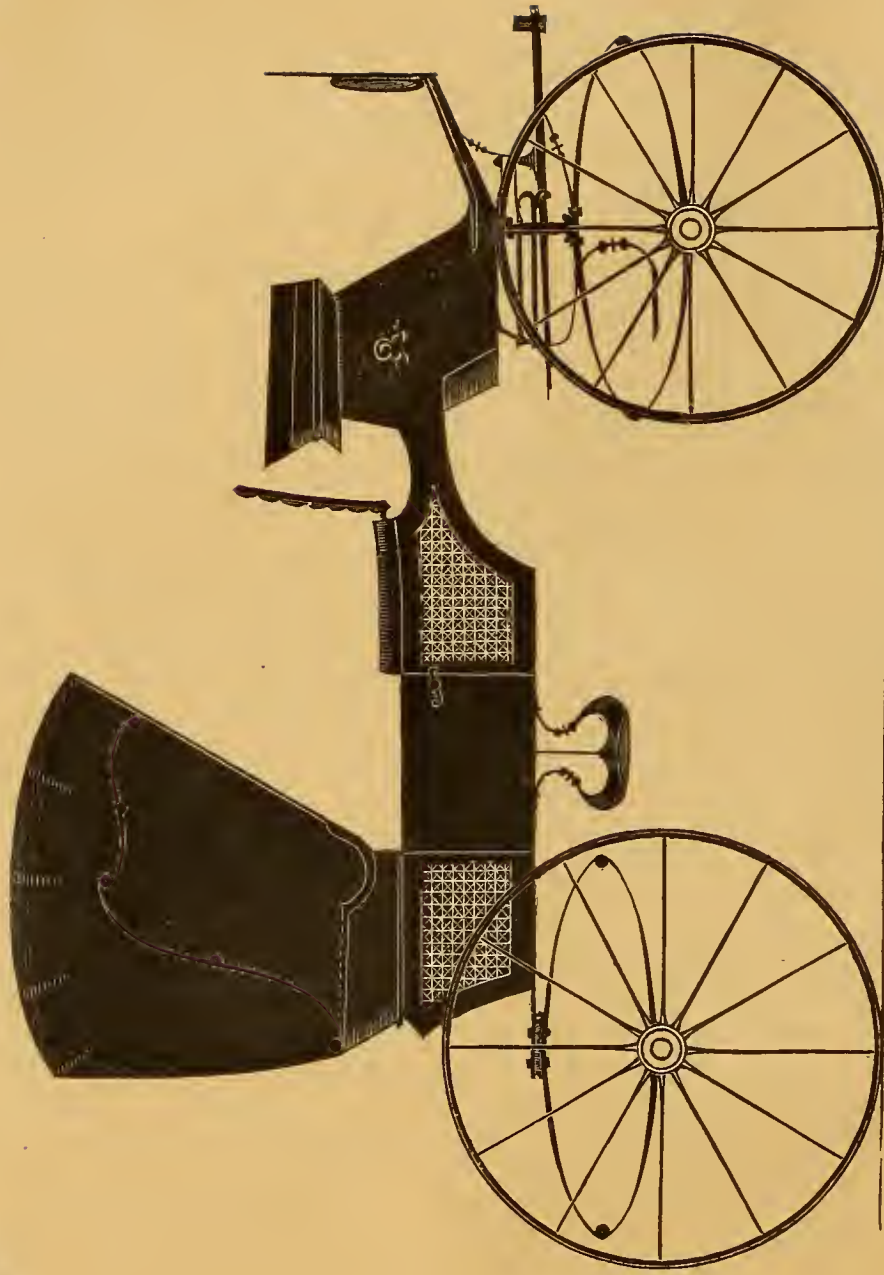

FOUR-IN-HAND DRAG.— $\frac{1}{2}$  IN. SCALE.

*Designed expressly for the New York Coach-maker's Magazine.—Explained on page 40.*



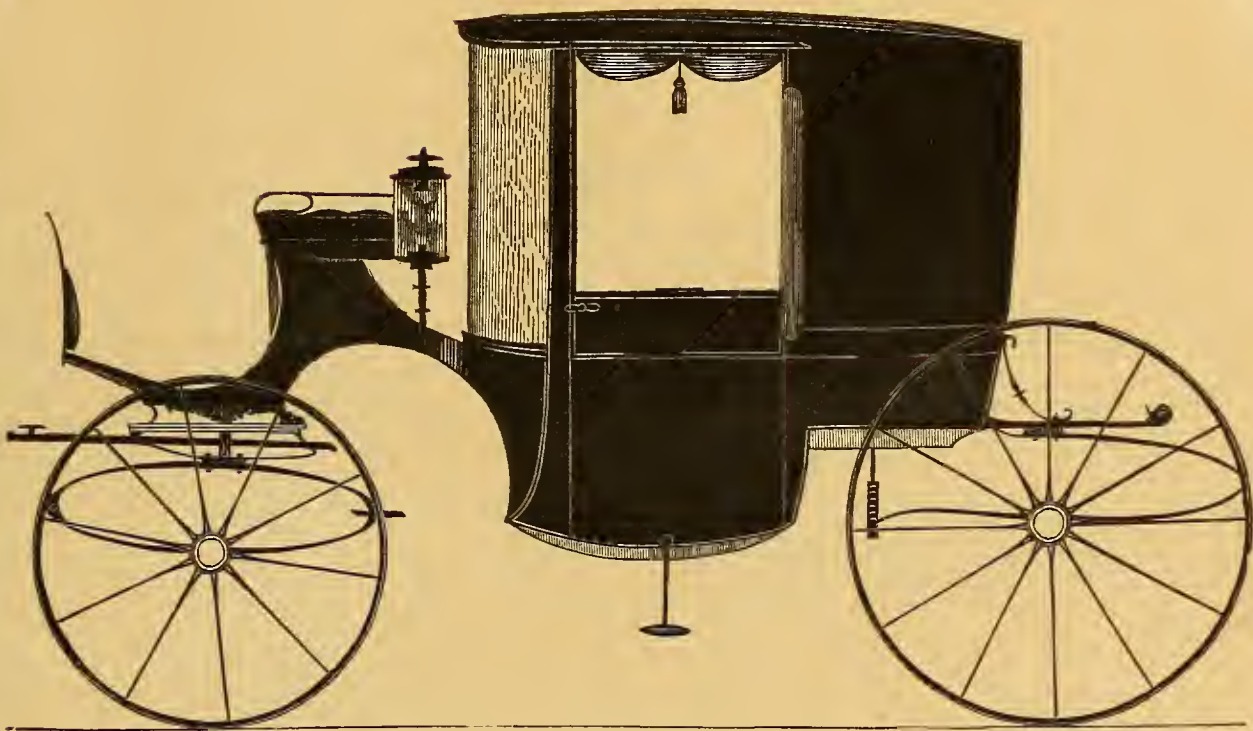

FAMILY COUPÉ.— $\frac{1}{2}$  IN. SCALE.

*Designed expressly for the New York Coach-maker's Magazine.*

*Explained on page 40.*



SCROLL-BUGGY.— $\frac{1}{2}$  IN. SCALE.

*Designed expressly for the New York Coach-maker's Magazine.*

*Explained on page 40.*



No. 1.



No. 2.



No. 3.



No. 4.

ORNAMENTAL DESIGNS.

*Designed expressly for the New York Coach-maker's Magazine.*

*Explained on page 42.*





DEVOTED TO THE LITERARY, SOCIAL, AND MECHANICAL INTERESTS OF THE CRAFT.

Vol. V.

NEW YORK, MAY, 1863.

No. 3.

## Mechanical Literature.

THE TIREVILLE MISCELLANY;  
BEING SELECTIONS FROM THE PRIVATE JOURNAL OF JOHN  
STILWAGEN, ESQ.

BY THE EDITOR.

(Continued from page 2.)

Sept. 4.—This morning I went to my shop in a satisfied frame of mind, hoping that, having overcome some of the difficulties which naturally attend almost every new enterprise, I would hereafter find "bossing it" a more comfortable business. Vain delusion! for, having occasion to leave my factory for two or three hours in buying stock, when I returned I found one of my journeymen, who had a phaeton body in hand, had, in putting in the back-panel, split it in two or three places, and that, in order to get rid of the labor involved in preparing another—he being a piece workman—he had introduced some "dutchmen" into the parts checked, and smoothed over and chalked the same, intending thereby to "blind the boss" until his job reached the paint-shop, and he had received the pay for it. Under other circumstances the deception might have availed, but in this instance it proved a failure; for, in passing around among the men, and inspecting the progress of their work, I cast my eye along the surface of the panel, when I detected a dark line, of a suspicious nature, which a closer examination showed to be checks, as above stated. The discovery dispelled every good feeling I entertained in the morning, and very nearly drove reason from her seat. When my story is told the reader will judge perhaps that reason was quite dethroned. In a fit of excitement, I demanded—

"What is the matter with that panel, Hans?"

"Nothing, sare," was the ready response.

"Yes, there is! What are those *dutchmen* doing there?"

"What Dutchmen? Oh! you mean them le——"

"Yes; and I mean further to say that you must take that panel out, and put in another, or else——" and here, letting excitement get the advantage of coolness, I seized a mallet from the bench, and sent it clean through the *dutchified* body, leaving the Teuton to his disturbed reflections, and to put in another panel.

As I passed along, I heard him, in a loud whisper, say to himself, "If I shall put in von, de poss vil hav to bay me for it."

Nov. 5.—This day the distinguished Squire Lookafter-em called upon me to order a family carriage built. With the aid of some drawings I placed in his hands, I was given to understand what kind of a vehicle he wanted, for building which I asked \$375. "Oh!" said he, in seeming astonishment, "I can get such a carriage as I want made in Shintown for \$300." My estimate showed the first costs involved in the construction to be at least \$325. After a long talk with the gentleman, I failed in securing his custom, and consequently lost the honor of doing his work. I suppose, however, my Shintown neighbor obtained the job, and in filling the order he will undoubtedly pave the way for the sheriff to enter his shop, when I will be able to make something by bidding off the creditors' stock at a low figure. Musing over this circumstance, I have determined to send all these unprofitable shoppers to Shintown, and so kill my competitor with kindness.

I had no sooner got rid of the squire, when a gentleman of the "colored persuasion" introduced himself with a polite bow, saying that he understood that I could make a better road wagon than could be had at either Scrabblehill or Shintown, and that his "boss" was about to order a new one. With an air of confidence, he added, "If you will drop in at 25 Marble-hall Place, about 7½ o'clock this evening, you will very likely get the job, as I have used my influence to get it for you." The idea of being the best manufacturer in Hub County was flattering, indeed, and there is no telling how high my ideas would have soared, had not the "darkey" upset everything with the question: "Boss, have you got any loose change about you you could give a feller?" The confidence of my visitor was only matched by his absurdity in asking "for loose change" of a carriage-maker.

Nov. 21.—Reflecting over the trials and difficulties of the past eight months, I have arrived at the conclusion that the man who, driving an ass, listened to the whimsical advice of those he met in his journey as to how he should treat his long-eared animal, had an easy task in pleasing all, compared with that imposed upon one who undertakes to get a livelihood by carriage-making. I scarcely need particularize here; for every time a customer calls on this *unfortunate class* of mechanics to examine their

stock, these difficulties will suggest themselves. If, in addition to the gentleman's own taste, his lady's also is to be satisfied, the task is multiplied tenfold; and I certainly can but envy the position of the fellow-tradesman whose talents gives him the ability to please the fancies of a tenth part of the customers that call upon him *in this over-nice age*. Smartness equal to such emergencies ought to be better rewarded than coach-making affords.

Feb. 10.—Had a very hard day's work *shinning around*, and, after all, just escaped having my note protested. I think I will never suffer myself to fall into such a contingency again. Having the promise of \$500 this morning, *without fail*, I made no other provision; but depended entirely upon this amount to take up my "promise," hence the narrow escape.

April 6.—Made a good sale this morning, I conclude—providing the "paper" given is paid at maturity. Taking notes in pay does not come up to my idea of value—is not equally as safe as taking the *tin*,—but, then, where business men set up a determination to deal in no other way, in these "degenerate times," they will find their business diminishing. Having, on a former occasion, had a little experience of the risks incurred by dealing with strangers, I expended a little extra labor to ascertain the responsible character of Mr. Hardface, before trading with him. Among others he referred to J. Confidence, Esq., doing an extensive business in Change Street, and to Mr. Smoothemover, of Windabout Lane, and to a third person—Mr. Twist, of Totem Avenue,—all, as I afterwards found, the particular friends of my customer. Instead of calling upon other references for the desired information, as I ought to have done, I visited, first, the squire, with the following result:

"I presume I have the pleasure of addressing J. Confidence, Esq.?"

"Yes, sir! I sometimes answer to that name."

"Are you acquainted with Mr. Hardface?"

"Of Confidence Place? Oh, yes! have known him a long time."

"Ever had any business transactions with him?"

"Yes, several thousand dollars' worth, *and always found him right.*"

"Would you trust him, or take his note, at three months, for three hundred dollars?"

"Certainly; I would be glad to sell him ten times that amount. Why, I have never entertained any doubt of his willingness and ability to pay for all he will buy."

"Have you any acquaintance with Mr. Smoothemover, of Windabout Lane?"

"But a very slight one."

I next called at Smoothemover's place of business. "Is Mr. Smoothemover in?" I inquired of a chap with a pen stuck behind his ears.

"Yes, sir; he will be disengaged presently; sit down a moment."

Mr. S., hearing his name mentioned, soon came forward.

"Well, sir, what can I do for you?"

"I came in, sir, to inquire about the responsibility of Mr. Hardface, of Confidence Place. You are acquainted with him, I believe?"

[Reflectingly.] "Mr. Hardface!—let me see—Mr. Hardface. Oh! that is the gentleman living at Confidence Place. Well, sir, I think he is 'all right.' I have always heard him well spoken of—believe him to be perfectly

honest—would be glad to sell him and take his note for any purchase he might make of me."

Without troubling myself any further, my inexperience led me to conclude that Mr. Hardface was honest and worthy of trust; with what result, will appear hereafter.

(To be continued.)

## DISH OF WHEELS AND TAPER OF AXLES RELATIVELY CONSIDERED.

BY J. R. GATES.

MR. EDITOR:—I ask the indulgence of your readers while I occupy your very valuable space and their valuable time in telling them something they may possibly know all about. This must always be the case to some extent in writing for such a journal as THE NEW YORK COACH-MAKER'S MAGAZINE, and addressing a class of men so intelligent as coach-makers generally. The subject I now undertake is one of great importance to every builder and purchaser of a wagon or carriage, and also affects the animal drawing it.

The defects in wheels and axles are so various that it would be difficult in a single article to point them all out, and give the remedy for each case. The fact is, a whole number of the Magazine might be filled, and, after all, new cases would still come up, which would need a new remedy. To avoid all this, it is necessary to apply the remedy before the disease commences. No doctor can cure a patient unless he understands the complaint; neither can any quack coach-maker cure the *disease* in an old coach unless he understands the cause of the trouble. When a buggy or wagon axle commences to heat and cut, it is (or should be) sent off to be doctored. The workman to whom the application is made (if he be a quack doctor in his line) takes off the wheel, and, with an assumed air of astonishment, tells his customer—"Oh! your axle is all cut out; you must have a new axle;" and at once proceeds, without ever trying to ascertain the cause, to put in a new axle exactly like the one he took out, but which is no remedy for the disease.

But *the quack* may say, "I do the best I know how." If so, it is his own fault; he does not take the NEW YORK COACH-MAKER'S MAGAZINE, or he would have known better. ["That's what's the matter."—ED.]

After what has been said by your able contributor, H. H., on this subject, in the last volume, it would seem superfluous for me to add words to what has been so well explained. I shall not, therefore, attempt to go into a lengthy mathematical explanation here, but simply give the rule I have used for years, and show as plainly as I can the reasons why it is mechanically and mathematically correct. In doing this, I may occupy ground that has been gone over before in your pages, and if so, I can only say, Use what is useful, and pass by what is not.

The first great point in the construction of wheels and axles, to obtain a perfect wagon, is to shun all avoidable friction. To do this three things are necessary: a perpendicular spoke, a horizontal axle base, and to have the weight equally divided on the but and point of the hub. The necessity of a strict adherence to these points has been so well explained by H. H., in Fig. 9, page 187, Volume IV., that I deem it unnecessary to go into any further explanation. These points being admitted, the next ques-

tion is, How can we maintain these three points in all cases? Only by making the dish of the wheel to correspond with the taper of the axle, or the taper of the axle to correspond with the dish of the wheel. The dish of the wheel and taper of the axle have such a relative connection and dependence on each other that no law of mechanics, no rule of workmanship, can make a light-running wagon or buggy without considering both these points, and making them harmonize with each other. To illustrate this, we will take a common wagon wheel, with a taper of one half the size of the but box, and ascertain *what must be* the dish of the wheel to maintain a perpendicular spoke and a horizontal axle base,—for we have settled the point that these two things are essential. Let us take the draft-board and see if we can accomplish *these* objects.

We have said that the base of the axle must always be horizontal. Here let me remark that all our calcula-

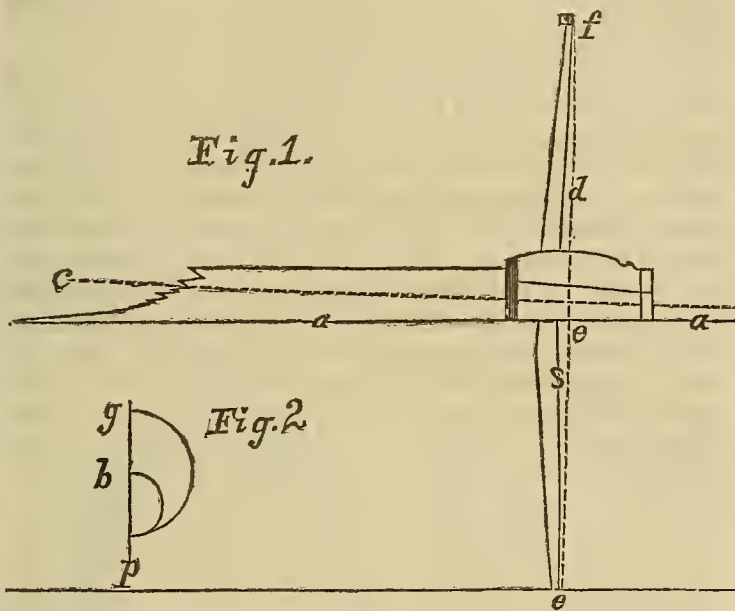

tions must be based on the supposition that the roads are level, as no calculation can make a perfect wagon for side-lining roads. Line *a*, Fig. 1, then, represents the base of the axle. Above this line draw the but and point of the hub, showing the size of the but, point of the box, and length of the axle, crossing the base line at the centre, at *e*. This gives you the centre of the rim of the wheel, at *b*, at right angles with the base of the axle, thus dividing the weight of the load equally on each end of the hub. Here let us remember that these lines showing the axle also show the internal surface of the hub. Now as we have clearly shown that the spoke must stand perpendicular, and always remain at right angles with the base of the axle, or internal surface of the hub, let us follow it as it travels around the tapered axle, until it makes half a revolution, when we find its position entirely changed. Let us now find out the cause of this change.

The but box being 4 inches, as shown in Fig. 2 (the point box being but 2 inches), following a line drawn longitudinally through the hub from but to point, and starting at *P*, the base of the axle, will travel to *g* at the but and *b* at the point, both ends arriving at the same time, *g* traveling over twice as much space as *b*, consequently it must rise to a greater height in performing a half-circle, thus throwing the internal surface of the hub higher at the but than at the point, and causing the spoke that stood

perpendicular on the ground to lean out at the top. A line drawn from the points of the spokes across the hub will show the exact dish of the wheel required for a 4 to 2 inch axle. Here you will notice that the dotted dish-line, *d*, in Fig. 1, and the line *c*, drawn through the centre of the axle, cross each other at right angles. This will always be the case in any amount of taper, or any amount of dish we give axles, thus giving another proof of the mathematical correctness of the rule.

But it may be said, "My wheels are made, and I can't change the dish in them." This being the case, let us see how our rule will apply the remedy. First, draw the perpendicular spoke line, *s*, as in Fig. 1; and, next, take the horizontal axle line, *a* (as we have shown these to be indispensable); then ascertain the dish of your wheel, and mark this forward on the axle; then take the dish line, *d*, from the face of the spoke; cross the spindle at *e*, to the top of the wheel at *f*. This shows the dish line of the wheel, which is fixed by the wheels already made. Now find the centre of the but box, and from this point draw a line, *c*, crossing the dish line, *d*, at *right angles* with it. The distance from the base line to this line at the point of the hub is exactly half the size of the point box needed to suit this dish of the wheel, thus showing that *this* "rule will work both ways." In another article we shall try to show the difference there is between the motive power of a buggy wheel and that of a pulley in machinery, thus bringing us to examine the subject of "gather," and show why it is necessary.

#### POWER OF AXLES, &c.—MEARS' REPLY TO HARPER.

MR. EDITOR:—I fully appreciate your attention in forwarding the copy of an examination of the two articles on axles in the Magazine for July last. My delay is consequent upon the repeated perusal and examination of the review, so called. *I do not know what to make of it.* On referring to my article, I find my views are entirely misapprehended, and my language not correctly quoted. I spoke simply of the obstruction, saying nothing of the peculiar power applied by man or beast.

The fact I attempted to establish, that small axles are to be preferred, is admitted. To my mind this is enough, and all beyond is supererogation. I have no particular desire to lay down scientific principles to govern mechanics by, therefore shall not be answerable for any mischief growing out of them; but I have used in moving stone the crow-bar or lever of the first class, the nut-cracker of the second class, and the shuttle-bar or "picker-staff" of the third class, in the store and on the vessel's deck, at the "Ready about!" and "Hard a'lee!" and have found the *wheel axle* a powerful auxiliary in "rounding in the main sheet," and "aft the fore sheet." The *pulley* has never failed to do good service when loading and unloading barrels from a wagon, a plank serving as an *inclined plane*, affording relief. In pressing cider, the *screw*—which is but an inclined plane wrapped around a cylinder—gives efficient aid. I have found the *wedge*—which is but an inclined plane under rectilinear percussion—powerful in splitting wood and granite, &c. These *six old mechanical powers*, which, I think, all readily resolve themselves into the principles of the lever—these have been, now are, and long will be, scientific mechanical principles, which, when

well understood, may be applied in making wheels, putting in axles, and building wagons, and performing any other mechanical operation, even to the building of plows, which are but levers, the beam and offset of the mould-board serving as the longer and shorter arms.

I was surprised at learning the extent of the rebellion, and, until the perusal of your last number, I was not aware that two of the six mechanical powers—the wheel and axle and the pulley—had “seceded.” They are so deeply involved in this matter and the general good of the public that the “union” must be restored and preserved. My mare tells me that she perceives as much difference in hauling a stone-drag six rods, or three, as there is in eating one or two quarts of meal; and I believe her, for she knows what friction is as well as which will fatten most. She suggests also that it is not expedient to break up brick-bats, and put them into a chambered wagon-box, in order to test abstruse questions of friction; but that *quantum sufficit* of hog's lard and black-lead, and a sprinkling of flax seed will enable any horse to haul a wagon over a half-inch obstacle.

The wheel is of but little use except when in motion. Having now driven the wedges into the spokes, I propose to put the tire on by referring to that able treatise on wheels found in the book of the prophet Ezekiel, where, looking down through the dark-rolling vista of ages, he appears to have had his eyes upon this very subject when he speaks of “a wheel in the midst of a wheel” (axle it may be), also of a wheel having four faces—1st, the point of agreement; 3d, the point of disagreement—and of a wheel full of eyes, significant of the eyes of all the earth, the craft included, being upon this discussion to obtain the needed instruction. The wheels were on each side, and went straight forward, like rail-car wheels; their height was dreadful—probably like *our* buggy wheels; they turn not without difficulty, *and their height is dreadful indeed*, when we attempt to help a girl, in her hoop-petticoat, of equal diameter with the wheel, over the side into the buggy, and from which her most convenient exit is by stepping back over the hind axle to the ground, on which may we all stand upright with a perfect understanding. And now, Mr. Editor, having treated the subject in as *diversified* a manner as there are spokes in a wheel, *I trust it will not soon become rim-bound, and require that the tire be reset!*

JOHN MEARS.

#### WHEELS OF IRON AND WOOD.

WE copy what follows from a late number of the London *Practical Mechanic's Journal*, because we are willing to let the reader know all that may be said in favor of the practical utility of iron wheels, without any intention of indorsing the writer's opinions. Our sentiments in regard to them, heretofore freely expressed, must have convinced those who have habitually read our pages that we have but a very poor opinion of wheels made of iron for common road carriages; and evidently the English writer himself is not one of the craft, and therefore illy qualified to recommend them from a practical stand-point:

The advance made from the pristine solid disc of round timber, hewn across the grain, and from the knotted root-wood, which even still in some remote regions of Europe,

and in many parts of Asia, forms the wheel of the agriculturist's wain or the Ryot's hackery, to that framed of nave [hub], spokes, and felloes, was very great. It probably was not made all at once to the form and principles of our modern dished wheel. The latter, if we consider what an insistent load it will sustain, what hammering over paving, etc., it can bear, the time it will last, and the excessively small amount of material from which all this work is obtained, is among the most beautiful results of human ingenuity. It owes a good deal of its springing resistance to the way in which any force applied at one point in the plane of the wheel is transferred in thrusts or pulls all round the circumference and centre, and partly to the skillful way in which the elasticity of the timber of the spokes is evoked by constant limited amount of transverse strain. In short, it is a combination of surprising strength, even transverse to the plane of the wheel, its properties in this direction having given rise to its having been employed in barbarous times to secure the struggling wretch when bound and “broken upon the wheel.”

As compared with any other construction of wheel that has been devised for common road carriages, it may be safely stated that the old wood-spoked wheel, with shrunk-on tire, still remains the very best, although dozens have been patented, and others invented but not patented. But the old wood wheel is expensive, even with the aid for forming it of all that wood-cutting machinery has in latter years effected; and the timber, even of the best quality, rapidly suffers by decay at some vital points, as a necessary consequence of its construction; thus the violent cross-strain brought upon the tenoned ends of the spokes, in the mortises of the nave, soon permanently compresses a little the spoke timber here, especially when swelled by damp weather; the next draught or heat, and the spokes shrink; the mortises become now a little too big, water enters, drawn in with power by capillarity, and then, after a time, the nave at heart and the spoke-ends become rotten. The same thing, but less rapidly, happens with the mortises of the spokes in the felloes. These evils have been sought to be radically cured by the substitution of various forms of wheels wholly of iron. Of these, probably Jones's patent suspension wheel, with wrought or cast iron rim and nave, and wrought iron rod spokes, always under considerable initial tension, had the most extensive trial. Many of us may remember in our youth having seen them under wagons, etc., in considerable numbers, in London streets; and an old pair may even yet be seen, belonging to some respectable house that entertains the time-old Tory notions of adherence to whatsoever it has once adopted. The noise and jar of these wheels upon the pavement, however, were abominable, and they sometimes broke in a very sudden and unexpected manner, and have, in fact, had their day. Many attempts have again been made to produce a wheel partly of iron and partly of wood. Some of the earliest formed the nave of cast iron, with sockets, into which the spokes were driven, the felloes and tire being as usual. Here, indeed, the naves no longer rotted, but all the causes operative to their loosening were in exaggerated play, and the spokes themselves became loose, and rattled in the iron naves, and finally rotted and broke off short. This was a Scottish invention, we believe.

More recently wheels have been produced with nave and spokes all of iron, and with timber felloes interposed between them and the outer iron tire, which was either



laid on in lengths and bolted through, or in one ring and shrunk on; and of this class there have been many varieties, bad and good. Amongst the former set, we noticed a pair of wheels upon a small field gun in the late exhibition, in which the spokes were made of thin, flat bars, each circumscribing a sector (as in the arms of some railway wheels of old pattern); one end of the bar was secured to the cast iron nave, passing out from it radially, then took the curve of the segment of the periphery, and returned radially back again to the nave, each pair of radial bars laying close together in adjacent sectors, to form one spoke; round the completed circumference of iron spoke sectors, a rim of wood, like a continuous felloe, was placed; this was shod outside with a shrunk-on iron tire, and the latter was bolted through the felloe-wood to the spoke sector within. The mode of connecting the flat spoke inner ends to the naves is not worth describing, as it was even more unmechanical than any other part of this, which may be pronounced the *ne plus ultra* of a bad wheel. We may pity the power that should be cajoled by supposed cheapness into trusting its field artillery to such means of moving it.

In the exhibition, but in an altogether different quarter of it, we, however, noticed another form of combined wood and iron wheel, which appears to us the best wood and iron wheel we have seen, and which, although apparently now some time in use, and with, we suppose, some established reputation by time, we do not recollect having ourselves previously seen. This is Mr. George Parsons' (of Parrett Works, Mastock, Somerset) patent wheel,

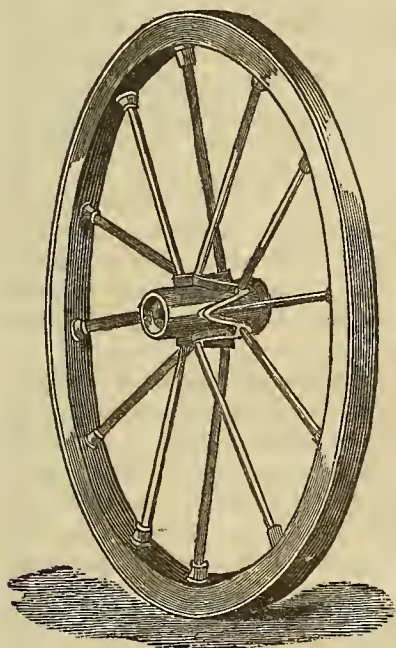

of which we give the annexed engraving. The nave is of cast iron, ribbed in a sort of herring-bone fashion all round, from spoke to spoke, so as to give a form of much strength without much weight. The spokes are of round wrought iron, and are screwed or cast into the nave. The outer end of each round spoke is screwed, and has a cast or wrought iron or other shoulder collar screwed down over it, leaving the extreme end of the spoke projecting. A timber felloe, which may be in one piece all round to a single lap joint, or might be made in plies of bent ash, or, as in the wheel we saw, in lengths with butting ends, is bored at the proper intervals to receive into auger holes the ends of the iron spokes, passing nearly through the felloe. The iron tire is now shrunk on (or might be bolted in laps, but is best, we think, shrunk on), and, when cold, the shoulder collars are screwed up outwards from the centre upon each spoke, until all are set up hard against the timber at the interior edge of the felloe. Of course some water-resisting stuff, like white lead in oil, or the like, may be placed beneath each collar before being so screwed up. Now here is an extremely easily and cheaply made, and an extremely strong and very durable,

wheel. They are sold cheaply, it would seem, too, for on the price list pasted over the wheels we saw that a pair to carry one ton, on 2-inch axles,  $4\frac{1}{2}$  feet in diameter, with a tire  $3 \times \frac{1}{2}$  inches, was priced £5, and a pair to carry three tons, 5 feet in diameter,  $5 \times \frac{1}{8}$  tire, was £11 7s.

Constructively we consider this the best combined iron and wood wheel we have seen. Several slight modifications in the detail of construction are conceivable, and perhaps in one or two points might even still further improve it, but precisely as it is made, and as it was exhibited, it is an excellent result of practical skill, and we are much mistaken if it prove not so in actual use.

## THE MOTIVE-POWER OF WHEEL-CARRIAGES.

BY H. H.

(Continued from page 19.)

THE effect of a wobbling wheel on the wear and the motive-power of a wagon is an important consideration. A wheel will never wobble when the box is set into the hub so that a straight line, extended from centre to centre of the two ends of the box, will be at a right angle to the plane of the periphery of the wheel, and any departure from that angle will always produce that wobbling motion. It is an easy matter to set the box into the wheel exactly upon that angle, and it is an easy matter to detect this kind of a defect in a wheel by raising up the axle so that the wheel will turn around, and placing a block on the ground so that it will be stationary by the side of the wheel, then turning the wheel around, and if the wheel rubs the block all around, then you are sure that the box is placed in the wheel on the right angle; but if, after touching the block, as you turn it around it begins to depart from the block, and does not touch it again until it has turned around, then you may be sure that the box is not set on the right angle. This way of detecting the imperfection suggests the way of remedying it when setting the box into the hub, which is so familiar to the craft that it is unnecessary to go through the details. All that is necessary to be said on the subject is to demonstrate the necessity of the mechanic being more careful in setting the box. If it is set wrong, no skill in giving a proper pitch to the axle can bring it right again, although it may be helped to a certain extent, as we can see by examining the effect that it will have on the bearing. We shall have to turn to Fig. 8, on page 172, Vol. IV., to illustrate the effect that it will have on the bearings of the box.

If we draw a straight line on the ground as long as the circumference of the wheel is, and draw a wheel that has no wobble the length of the line, it will track exactly on the line. Again, if we take a wheel that wobbles one inch, and is not properly set on the axle, and draw it on the same line, it will commence departing from the line, and continue to do so until it has turned half-way around, when it will be one inch from the line. From this point it begins to approach the line, and continues to do so until it has performed its revolution, and then it has come back on to the line again. At the time that it had performed half its revolution, the bearing would be the same as one inch departure from a perpendicular, in Fig. 8. If the spoke had started on a perpendicular position, and the pitch of the axle was not right, the wheel would come into a right position, where the bearings were equal, only

once during the revolution, but on the opposite side from this point the bearings would be as they have been before described, when the spoke was one inch out of perpendicular, 312½ pounds on one end, and 187½ pounds on the other. Also, as we have seen, where there is the most bearing there is the most friction and wear, therefore in this case, if the theory which we have advanced is correct, the box will not wear round, but elliptical on the part where the bearing is the greatest. My experience in overhauling old wagons, coaches, &c., has always found this to be the case, without a single exception. In addition to my own experience, I have that of a Mr. George Ellis, who for a number of years has been agent for the Wisconsin Stage Company, and who has had a chance to know, and does know, as much as any man that I am acquainted with about the wear and defects that a carriage is liable to. He told me that he had always found that a wobbling wheel wore the box into an elliptical shape, and if the defect was not remedied, the wobbling would increase until the wheel would become entirely worthless. I am more particular about stating this fact, because it conclusively proves that the theory which we have advanced in relation to the wearing of the box and axle unevenly is correct. A wheel that has this wobbling motion can be helped to a certain extent by giving the axles exactly the right pitch. In this case, if we have a straight line drawn on the ground, and have a wheel that will wobble one inch started on the line, it will depart on one side of the line one half of an inch when the wheel has turned one fourth of the way around; from this it would incline to the line until it had turned half way around, when the wheel would come on to the line again. From this point it would commence departing on the other side of the line, and continue to do so until it had turned three fourths of the way around, where it would have departed one half an inch, and from this point it would incline towards the straight mark until the wheel had performed its revolution, when it would stand on the line again. By this it will be seen that a wheel with the same wobbling motion stands on a perpendicular spoke twice in one revolution, and the departure from a perpendicular is only one half instead of one inch. The bearings on the axle when the wheel stood the most out of place, would be 281½ pounds on one end of the axle and 218¾ pounds on the other (of the 500 pounds' pressure), and the wear would be in that proportion.

From the course of reasoning that we have pursued in investigating the motive-power of wheel-carriages, it points invariably to one result, and that is, that there is but one philosophical way in constructing wheel-carriages, and any departure from that one way involves an extra expense of motive-power. In the commencement of this subject, I am free to admit that the enormous amount that the calculations made of difference in the value of wagons made me hesitate about starting the subject with assertions that had such an extravagant appearance; and if those assertions could not have been proved by the most simple and plain mathematical rules, I should never have dared to advance them. So far as we have pursued the subject, which has been under three of the four heads which we proposed, it very clearly explains away, to my mind, the appearance of any extravagance. The inequality of the bearings on the axle-arm has always been regarded by the craft as one of the most difficult parts of the trade to avoid; and yet there are few but what will

say they know how to give the axle exactly the right pitch; but ask them how it is done, and you will find that it is as inviolable a secret as ever belonged to any secret association. Some unquestionably cover their ignorance of the subject by a convenient garb of secrecy; but it is certain that a great many are deceived in the rule which they have adopted; for nothing can be made more apparent than that it is seldom that a wheel-carriage is evenly balanced on the wheels. If the end of the pole or perch deviates from the proper position, it is regarded as a great mistake on the part of the mechanic, and the wagon would be turned on to his hands. Why is this fault made so grievous? It certainly is not any worse than balancing the wheels wrong on the axle! The answer is plain. In the former case there is a plain, simple, and positive rule to work by—*no secret about it, and very seldom a deviation from it*; in the latter case, if there is any positive rule to work by, it is seldom known, and the fact of its obscurity implies an obscurity of any means to detect any defect which that part of the construction may have. I intend in the course of this investigation to give a rule that is as plain, simple, and positive, and as easy to work by without making any mistake, in the latter case as in the former. By so doing, I shall claim the honor of benefiting the world to the amount of millions of dollars saved, unless some one steps in before me and voluntarily makes this secret, that has been so inviolably kept, public, thereby nipping my anticipated honors in the bud!

#### PERAMBULATORS IN LONDON.

A CORRESPONDENT of the London *Builder* says: There is a nuisance in our streets—a libertinism of locomotion, and yet a great obstruction to the free progress of peripatetics. It is a grievance of long-standing, as old as the days of Sedan and Bath Chairs. These last have, indeed, been continued, and appear to be indispensable, so long as valetudinarians continue to reside in the suburbs, and to consult the reputed and learned in medicine; but the "*chaise à porteur*" disappeared from town upon the introduction of coaches, when the groves of Hackney as erst allured our wigged and powdered beaux to suburban enjoyments.

Since those days the population is increased tenfold, although the causeways, which have been increased proportionally in number, have not been enlarged or widened in a corresponding ratio. Were it not for 10,000 omnibuses and as many cabs, all free circulation must be at an end in a population of three millions, seeing that the public grounds for recreation, the parks and squares, are no larger than they were in ancient London. Thitherward it is that the tide sets in of those who seek for some vestige of rural scenery, if not for exercise of fresh air. The great majority of these are children, and their vehicles, called perambulators, are drawn, or more generally propelled, by maid-servants or very young girls; invalids are invariably *drawn* by steady men.

Now the evil complained of is the incessant roll of perambulators which is encountered on every (the narrowest) pavement. They are propelled from behind by young girls—seldom by a nurse-maid out of her teens. They are shot forward or zigzag quick as the momentum of lightning or the fancy of the wild conductress. On a broad pavement, as you approach, leave them a wide range, for the slightest nervous excitement in the guide gives the

swift engine a fearful velocity, with a direction wholly unexpected. Though bad enough in Westbourne Terrace, what is it in Oxford Street, thronged as it always is at the meridian hour? It would be hard to enact an interdict which would in any degree restrict the air and exercise essential to the large proportion of the generation now in infancy; still it might be required, without much cruelty to them, and the conductors should be, as in the case of Bath Chairs, of mature age, if not of stalwort growth.

A serious concussion and contusion, with fracture of the velocipede, which occurred in Edgeware Road the other day, induces the writer to suggest for the consideration of the police authorities that some attention be given to this increasing nuisance; and that as the conductors and drivers of cabs and omnibuses are obliged to wear badges, and be designated by a number, so the drivers of the perambulators should be subjected to official inspection and approval, and if not numbered and labeled, at least certified as proper persons to drive our infant progeny, and teach the young idea how to shoot ahead.

## Home Circle.

TO FANNIE.

BY LUA DELINN.

THE gladness of childhood still thine, but its tears  
All lost in the flow of maturity's years!  
The dew of the morn with the brightness of noon!  
The freshness of May with the ripeness of June!  
O such is the beautiful blending I see  
In the picture of life that is sketching for thee!  
Is it perfect? One glance of thine eye would tell  
That a Master-hand hath drawn it well.  
But the Artist best knows if His work were made  
More perfect by *contrast* of light and shade:  
Oh, then, remember, *should* shadows fall,  
That a *Master-mind* hath planned it all!

## MILDRED: A SKETCH.

BY ANNIE M. BEACH.

DRAW the curtains closely. Shut out the cold, dark night. All day long have I sat looking out on the black clouds that have hidden the beautiful sunshine, and listening to the rain dropping and dripping from the crumbling wall and moss-clad, vine-wrapped eaves. I do not love to hear the rain beat and the wind wail. I thought it music once, but now it makes me sad, for I am thinking of the past—the strange, sad past.

Mildred Merton! I know not why I have thought of her so much to-day, when for years she has slept beneath the willows. She was not fair. Her great blue eyes looked out languidly from their golden lashes, and her broad brow was too high to be handsome, but when she smiled it was as a gleam of sunshine,—so we used to say of her.

Ernest Brant was the handsomest lad in school. They were always together in childhood—Ernest and Mildred—and when youth came on, with its wild visions, and hopes, and fears, they were still true friends. It was Ernest Brant who brought her sweet flowers from the meadows; it was he who lingered near her at the social party; and when winter came, and the sleighs went gliding over the shining, crusted snow, Ernest and Mildred

were still together; and we said they would one day stand side by side at the altar; but it was not so.

How the night wind blows! Come closer the glowing grate.

"Cousin Nellie has written she will come, dear Blanche," Mildred said to me, as we were walking beneath the oak trees. "Why do I dread to see my cousin? I am sure I do not know, but somehow it seems as though something sad is connected with it. Can you tell me why, Blanche?" Dear Mildred! Time taught her young heart the answer. And so, as the brown leaves of autumn were falling, Nellie Merton came among us.

"Oh, how beautiful!" So I said to Mildred, after the little fairy had greeted me as "Cousin Millie's friend," and gone from us. Her slight form was complete, her features faultless, and oh, such splendid eyes!—large, and soft, and black.

"How very unlike Mildred!" So said Ernest Brant an hour later, as he came into the garden where I stood. "But Mildred is *good*, if she is not *beautiful*," I replied. "Blanche, you know I prize Mildred's worth; to me she is *all*." He ceased, for Nellie Merton's black eyes were upon us, as she played with the tassels of the curtain at the window, and though she could not *hear*, we knew she *saw*.

Ernest Brant, *beware!*

We were much together—Mildred, and Nellie, and I—as the weeks stole on. Nellie won us all to her love, she was so childlike and artless. She sang such sweet songs, as we strayed under the oaks together; and then a wild flower or a spray of forest leaves fastened among her black curls, made Nellie beautiful, when among our locks of gold and brown they would have been unnoticed.

Thus the autumn glided away, and merry Christmas came at last. Oh, how long we had looked forward to that Christmas eve! Mildred's young friends were to be gathered at her pleasant home, and we had been weeks preparing for the party. But the night was cold and bleak, like this. How beautiful Nellie looked as she kissed me in the hall. The rich blue brocade she wore was so becoming, with its low neck and short, pearl-looped sleeves. There were bracelets to match on her soft, white arms; and oh, her splendid hair! "Please, Blanche, dear, will you go up and help Millie dress?" she said, blandly. "You know some one must be here to receive the guests;" and, taking Ernest Brant's arm, she left the hall.

"O Blanche! I am so glad you came up," Mildred said, as I opened the door of her quiet room. "I am sad to-night, and the wind wails so; I wish we could sit here alone all the evening. They would not miss us much down stairs—I am sure they would not;" and there were tears in Mildred's blue eyes. But no one knew she had been weeping, a few moments later, as she entered the parlor, and greeted her guests with the old smile of sunshine she always wore.

The storm wore away as the evening went by, and the moon came out full and clear, as Mildred and I said adieu to the last of her guests at the hall door.

Where was Nellie now? We entered the parlor again. The lights had grown dim, but we heard voices—first Nellie's, and then Ernest's. "Oh, Millie is my sister, you know! Believe me, Nellie, dear, *only my sister*—nothing more, I assure you." Dear, dear Mildred! She

had learned the answer to the question, "Why do I dread her coming?"

It was too late when Ernest Brant woke up from that wild enchantment; for the old love *did return* at last, after Mildred's eyes had lost their glad light, and her pale cheek had grown paler.

I did not weep when I looked upon Mildred in her grave-robe, but *Nellie's grief seemed frantic*. There are some who can weep when they are not sad, and some who can smile when their hearts are breaking.

Ernest Brant, too, "sleeps the sleep that knows no waking," but his grave is in a foreign land.

Nellie! Yes, I too have forgiven her *now*, as Mildred did. She has *gold*, but is she happy?

All things are just! We may not know why hopes are crushed and hearts broken, but in the angels' home there shall be no regrets, nor sighs, nor sad farewells.

### Pen Illustrations of the Drafts.

#### FOUR-IN-HAND DRAG.

*Illustrated on Plate IX.*

CARRIAGES of this kind appear to be very fashionable this season, and are a relief from the old style of crooked bodies made a few years ago, and which in this day appear very homely. The present taste demands straight-sided and plain work in everything of the phaeton kind, relieved with either cane imitations or carved panels. A water-deck, or lid with stop-hinges, to cover the middle seat when turned up, forms a very convenient back to the same.

X. Z.

#### FAMILY COUPÉ.

*Illustrated on Plate X.*

IN a late number of our Magazine, we gave our patrons a design for a Coupé sufficiently light to be drawn by a single horse. The original design which we now give is designed more particularly for a family carriage, with two horses, and has a rounded glass front. For the painting of these Coupés, in our judgment, there is nothing equal to patent black; but we notice that greens are coming into use again. Terry, green, blue, and red, which now costs \$7 per yard, is a good article for the lining, where the cost is not an object; but when cheapness is desirable, moquet, quoted in our Prices Current this month, will be found a very fair article for that purpose.

#### SCROLL BUGGY.

*Illustrated on Plate XI.*

A CORRESPONDENT sends us this design for a Scroll Buggy with a turnover seat—a novelty in some respects. On the panel of the side of the body is glued a raised fancy scroll, extending the entire length, and greatly relieving an otherwise monotonous-looking side, and adding an ornamental feature to the wood-work.

### Sparks from the Anvil.

#### CASE-HARDENING IRON.

WE hear a great deal from our axle-makers about steel-converted axles. These are nothing more than a superficial change of iron into steel, the surface alone being hardened. The following is the mode of steel-conversion: Having the article for conversion properly finished in the lathe, except the polishing, the next thing is to stratify it with animal carbon, the box being luted with equal parts of clay and sand. After this it is placed in a fire, and kept at a light-red heat for half an hour, and then the contents of the box are thrown into cold water. The animal carbon mentioned above is such simple matter as horns, hoofs, skins, or leather, charred by fire sufficient to admit of their being reduced to powder. The iron box may be dispensed with when the case-hardening process is on a small scale, as with our common smiths, by enveloping the articles in the composition as above directed, and using them as a lute. This should be gradually dried before it is subjected to heat, otherwise it may become cracked. The depth of the steel will vary with the time the operation is continued. Other modes of case-hardening we have given in Vol. II., pp. 70 and 210, and Vol. III., p. 191.

#### COMPOSITION FOR WELDING AND RESTORING BURNT STEEL TIRES.

WE present our readers with a useful recipe for making a composition to be used in welding and restoring tire steel. Take 2 pounds of borax,  $\frac{1}{2}$  pound of salammoniac,  $\frac{1}{4}$  pound of potash; reduce these in a mass to powder, by pounding, and make them into a paste by adding one gill of water and one gill of alcohol. Put this into an iron vessel, steaming the contents slowly, and stirring them all the while, until it forms a cake, which is then to be used in the same way as borax. A longer application of heat to the cake produces a capital article for restoring burnt steel. Try them.

#### COMPOSITION FOR WELDING CAST STEEL.

ANOTHER method, different from the foregoing, for welding cast steel, is to make a composition by taking ten parts of borax, one part of salammoniac, and after pulverizing, fuse them in a metal pot over a clear fire, continuing the heat until all spume has disappeared from the surface. When the liquid becomes clear, the composition should be poured out to cool and concrete. This should afterwards be prepared for use by grinding it to a fine powder. For welding, the steel should be brought to a bright yellow heat, and then dipped into the powder, and then again into the fire. When it attains the same heat as before it is ready for welding.

LUBRICATING COMPOUND.—A composition of tallow and coal oil is said to make the best lubricator for carriage wheels ever used, and is far superior to any patent wagon grease sold at the shops.

ENTERPRISING.—A rural carriage-maker advertises that at his shop "old wagons are made new, and new ones mended." Smart, that!

## Paint Room.

### COMPOSITION OF PAINTS.

BY H. HARPER.

(Continued from page 28.)

How to detect adulteration in white-lead—Zinc paints more difficult to spread with the brush than those obtained from lead—The union of oxygen with carbon beneficial to paints—Oxides of iron offer the greatest resistance to the action of the atmosphere of all other metallic paints—Dryers and their affinities—Oils protected from gases by gums, the qualities of the varnish showing to what extent—A hint to varnish manufacturers—Red-lead.

THE oxyd of zinc has been used as a substitute for white-lead, and if painters would exercise the judgment that the wants of the community demand, it would entirely supersede the use of white-lead. I am not familiar with the process of its manufacture, but suppose it is procured by exposing it to oxygen in some one of the various ways, so that it is reduced from the metallic state to the white powder which forms this beautiful white paint. This powder, like the carbonate of lead, is adulterated with other ingredients before it comes into the hands of the painter. In some cases we notice that which is prepared in oil, that when water is put on it to prevent its drying in the keg, it forms a hard cement where the water touches it, which indicates that it is mixed with plaster of Paris. Paint made of zinc has less of the drying quality than lead, and, although possessing less body, is more lasting when exposed to the atmosphere. As it has recently come into use, compared with white-lead, our knowledge of its lasting nature is somewhat limited; but, from what we have observed, there cannot be any doubt in my mind of its preference in this respect, where it is not exposed to friction. It is said that zinc is not poisonous when taken into the stomach, but there may be some doubts about its being free from poison.

We find a difficulty about spreading zinc with a brush, which we do not to so great an extent with lead. The brush marks are shown more plainly by the small ridges which the paint retains; whereas, in lead, they partially flow down. In carriage, as well as in many other kinds of painting, this difficulty is obviated by following the direction in Volume Four, on page 67, etc., of this Magazine. Otherwise than its not having so much body, a good article of zinc is superior to white-lead for carriage painting, because it can be worked down smoother by the brush.

Oxygen is said to be the destroying element that crumbles to dust from its original form almost all solid substances sooner or later; but, in its action in most substances, it is retarded to a great extent by depriving it of the co-operation of carbon. It seems as if there must be an uniting of the two gases to make it act efficiently, and the same process is required to make the oil with which the paint is mixed dry. As we have said, lamp-black, which is almost a pure carbonate of vegetable substances, will not dry linseed-oil, but when dried by a suitable dryer, will resist the action of the atmosphere longer than almost any other paint. On the other hand, Venetian red, yellow ochre, and all oxides of iron have no drying quality for the oil, but are the longest to resist the action of the atmosphere of any of the metallic paints. The course seems to be that, where the paint is reduced to a pure car-

bonate or oxyd, the respective gases will not interfere with them again to so great an extent, consequently the oil used to hold them together will not *dry* or *decay* as quick as it will mixed with other ingredients that have an affinity for the two gases.

For a dryer we use an oxyd of lead (red-lead), acetate of lead (sugar of lead), or sulphate of zinc (white-vitriol). In the last mentioned we have a strong dryer from a sulphate of zinc, while an oxyd has no drying quality to impart to the oil. A peculiarity about the acetate of lead is, that, when exposed to the atmosphere, it absorbs carbon in a short time, and to this peculiarity we owe the drying quality that it imparts to oil; for if we undertake to impart the drying quality to oil by heating it with the acetate of lead, we fail entirely; while, on the contrary, oxyd of lead heated with oil gives it a good drying quality. The contradictory operations of these dryers show that it is not the mineral itself that has any thing to do with drying the oil, but it is the uniting of two or more gases for which the mineral has an affinity.

Oil will not dry under water, or in any place where it is excluded from the contact of oxygen and carbon together, nor will it decay under such circumstances. We have never noticed any thing in the use of paints to contradict this general rule—that whatever tends to dry oil, be it by the way of the paint with which it is mixed, or a separate dryer introduced, the same will tend to the decay of the oil and a falling off of paint, which is the great difficulty to be contended with.

In carriage painting we do not meet with the same difficulties, because we use more or less of gums held in solution with oil that will not be affected by oxygen or carbon. For instance, they do not destroy copal gum readily. When this gum is melted by heat, oil and turpentine (or benzole) are introduced to keep it in that liquid state. The benzole or turpentine evaporates entirely when the varnish is spread on the paint, leaving the oil and copal gum to form a body over the paint. Now, as this oil shows resistance to the effect of the destroying gases, just in that ratio the quality of the varnish is determined. That which is of the best quality for preserving its gloss when exposed to the atmosphere invariably is that which dries slowly. When the oil decays, the gum assumes a porous, dead look. Perhaps the oxyd of the oil will give it a dirty, yellowish look; but the gum will not be destroyed, and it forms a complete barrier between the atmosphere and the paint which it protects.

I have noticed that when Damar varnish was used plentifully in oil, in painting the outside of houses, that the paint would last two or three times as long as that with which there was none used. These facts, which we have derived from personal experience, may serve as a hint for those who make varnish, in preparing the oil for the same. We cannot comprehend why there should be any difference in the lasting qualities of varnish when it is made in the same way, out of the same oil and gum, unless the difficulty originates from the manner in which the oil is prepared for drying. Another fact which goes to corroborate this view is, that the best lasting varnish is that which is slow to dry.

Red-lead is considered valuable as a paint, on account of its great body and the firm hard drying qualities it possesses, and, for some kinds of work, because of its color. It is an oxyd of lead but one degree removed from litharge. They are both obtained by the same process—that is, by

exposing lead to heat and the action of the atmosphere. The first oxyd that appears in the process is of a grayish color; more heat imparts to it a light orange color, which is the litharge of the shops; a still greater heat gives it a deep orange red, or what is called red-lead. On account of its extraordinary flashy color, it is mostly used for the running-parts of wagons. Where durability is required, it should not be used with oil prepared for drying hard, as of itself it is a sufficient dryer with raw oil.

(To be continued.)

### THE NATIONAL COACH PAINTERS' ASSOCIATION.

ON or about the 5th of March an association of journeymen coach painters, with the above comprehensive title, was organized in this city. Some persons may object to the propriety of the "coach painters of New York and vicinity" taking to themselves the designation of "national," but that is a matter of taste with which the public has nothing to do. Perhaps, however, some of the membership have embraced the *Wooden* notion that New York has "seceded" from the Union. Be this as it may, under the delusive impression that this is a free country we dropped in at "headquarters" the other evening to report progress, but, *unfortunately* for the nation, "being one of the bosses," we were politely requested to "vacate," and "turned out into the cold," with the only additional knowledge we took there—of knowing that we were not wanted. We, however, consoled ourselves with the reflection that a goodly company of wood-workmen, trimmers and blacksmiths occupied the same boat with us, and with the additional cordial that a meeting called for 7½ o'clock, P. M., one half hour thereafter, numbered fifteen nationals at least. In view of the "attentions" the National Coach-painter's Association bestowed upon us on that occasion, we are inclined to be liberal, and present the world with their circular, *verbatim et literatim*. Should any fastidious reader find fault with the *national* English, he must not complain of us.

"TO THE COACH-MAKERS OF NEW YORK CITY AND VICINITY:

"Gentlemen,—We, the Coach Painters of New York City and vicinity, take great pleasure in informing you that we have met in convention, and have organized a society, under the name and title of "The National Coach Painter's Association." The object of this society, and the desire of its members is not to plan or plot any thing whereby we can take the advantage of our employers, but to take into consideration the proper course to pursue, that which will result in the benefit and interest of both. After a due and impartial consideration we have unanimously concluded to ask your attention for a few minutes; while so doing, we assure you we will ask nothing at your hands only what is our just right to demand and your duty to grant.

"Gentlemen, we need not comment on this subject, as you are well acquainted with the enormous advance in prices of provisions, clothing, and in fact every thing which we consume, and the depreciation in the value of the money which we receive at your hands. Sirs, we have Wives and Children to support, to feed and clothe them as it is our duty to do, and it is our desire, as well

as the duty of every man, (and so you will decide we should,) if we have one spark of parental love or affection for our Children, that they shall be so instructed that when they shall become men and women they may occupy a position in society that will reflect credit to you as well as to ourselves for the encouragement and improvement of morality, and our children as well as your children may become good and useful members of society. Gentlemen, under present existing circumstances, when we take into consideration the approaching future it chills our blood, confuses our brain, and it is enough to drive us mad. [Here the author's madness leads him to forget that he is writing for any one but himself.] I have no doubt that many will ask the question, 'why?' I answer with the voice of many, the prospects for our children in the future is poverty, want, and distress, hence ignorance, crime, misery, and probably convicts, and inhabitants of a demoralizing cell, from a possibility of which, we appeal to you to deliver us, and we have every reason to believe that, in your judgment, you will so desire and freely grant us our reasonable request. We ask of you that Painters who are fully competent to take a job from the first and finish it in all its several departments \$2.00 per day, and the rest \$1.75 per day. If this should meet your approbation, which they certainly think it will, we assure you on our part that no man will be allowed in our society who is not fully competent, willing and ready to faithfully perform his duty with credit to our society and advantage to his employer. If you desire willingness in your workshop encourage cheerfulness in the domestic circle and it will result in your interest ten fold.

"We have the honor to remain, Your Obedient Servants,  
"THE COACH PAINTERS OF NEW YORK AND VICINITY."

### ORIGINAL ORNAMENTAL DESIGNS.

*Illustrated on Plate XII.*

WE need say but little by way of description or instruction, as the laws of the Herald's College are obsolete among us, and the tastes of individuals differ as to ornament and colorings. We therefore leave the artist room to exercise his own judgment. For those who want a dozen of them for transferring, we intend to publish that number on a sheet separately, all colored, so as to suit the capacity of all. This sheet, by mail, will cost \$1 each.

### Trimming Room.

#### FASHIONABLE TRIMMINGS FOR LAZY-BACKS.

ON page 11, of this volume, we gave our friends a diagram representing one mode of trimming Lazy-backs

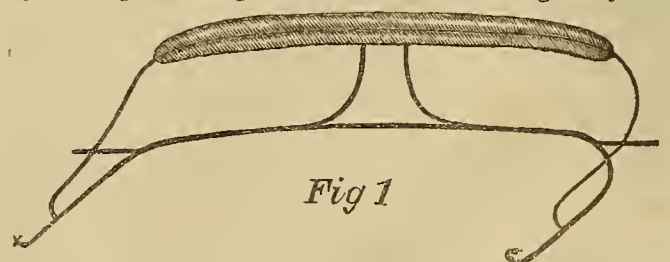

now in fashion. Figs. 1 and 2, here presented, illustrate two other styles very popular in New York city.

Figure 1 consists of two plain rolls or pipes of cloth, stuffed with curled hair. To make these, in the first place, cut two strips of cloth, lined with muslin, of the proper shape and fullness, and sew the middle edges together, with the welt in the centre, the entire length of the back. Next, nail the welt to the board in the centre, and nail the edges of the cloth to the upper and lower edges of the board, from the centre each way, stuffing each roll as you proceed, until you reach the ends. After this is completed, nail a double welt of leather around the entire edges of the back.

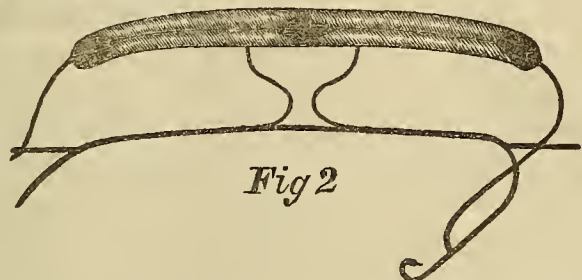

Figure 2 represents a similar style of trimming, but with patent leather spots or pieces inserted in the cloth at the centre and ends. These pieces are bordered with leather weltings, the pieces, weltings, and cloth being seamed together as in the former example before the linings are nailed to the back-board and stuffed. The ratan finish between the double welting around the back, as spoken of on page 11 of this volume, makes a very nice job of the whole.

### Editor's Work-bench.

#### ADVICE TO CARRIAGE-MAKERS.

SERIOUS commercial reverses, during the past two years, have, or ought to have, furnished business men with lessons of wisdom not to be slightly passed over. Carriage-makers, in particular, should give special attention to their teachings. Many who formerly nursed the flattering idea that they were on the smooth road to a fortune, now find that it was leading them into a slough of despondency from which they will be fortunate should they ever be able to extricate themselves. Some, we fear, are now so hopelessly ruined that anything we may give in the line of advice will be entirely lost upon them; to such we tender our sympathy. There are, however, a great number still young and ambitious, whose fortune may be benefited by an encouraging word and timely caution from us.

To those, then, who would reconstruct their business matters on a new foundation, we, with deference, offer a few suggestions. We suppose there will many be found who will not thank us for penning this article and interfering in what they are disposed to call their private affairs; but there are some still wise enough to listen to the dictates of reason, even though originating from a humble source. We would, then, suggest—

1. That no man ought ever to undertake the carriage-making business, except he be thoroughly acquainted with

it—first, has been apprenticed thereto. It is too artistic and complicated a pursuit for mere tyros.

2. Though an expert, don't attempt to do more business than your capital will safely warrant, nor give long credits, nor trust any one whose character and responsibilities are doubtful and unknown.

3. Never undertake to build a carriage until you have found an opportunity to examine into its costs, and never on any account take an order from a customer because Mr. B. offers to do so for a stipulated price, without feeling assured that *there is money in it for you*.

4. Do not, like too many others in the business, promise a customer that on a certain day his job will be finished and ready for him, when, at the same time, you know full well you cannot possibly accomplish it. Candor is a virtue with every mechanic, and a very necessary one in a carriage-maker. It is far better to tell a customer, on the spot, just what you can and will do, than to afterwards disappoint him by not having his work ready when the day set rolls round. Business-lying can never possibly succeed with an individual the second time in getting a job, and under every aspect is unprofitable.

5. Always distinctly impress upon the minds of your customers that you will not sacrifice a principle for the sake of trade, nor do anything your conscience tells you is wrong.

6. Keep such capital as correct business habits has accumulated together, until every liability is discharged, every debt satisfied, before lending it to other enterprises.

7. Should you contemplate entering into copartnership with another, first inquire well into his antecedents before taking so important a step, lest afterwards, when too late, you be visited with regrets never to be overcome. Many of our acquaintances have found themselves suddenly ruined, for the term of their natural life, solely by the dishonest acts of an unprincipled business partner.

8. In forming a copartnership relation, have it well understood beforehand just what each individual, from the profits, may draw out weekly for his private use; and the sum agreed upon should, under no circumstances, be exceeded.

9. We find in young men, for the most part, a disposition to be imprudent. They are too proud to begin business on a small capital, and, therefore, when they can, commence with more capital than experience. These are almost certain to "burst up" in a short time. A small capital in industrious and economical hands succeeds better than a large one with an inexperienced head and haughty demeanor.

10. Never borrow money if it can possibly be avoided. If you do, you must lend in return; perhaps in cases where responsibility is doubtful. Remember that "the borrower is a servant to the lender," and in every case such resort is more or less a source of trouble to him.

These are some of the rules that should govern the business pursuits of a carriage-maker. He should estimate integrity above money; value his character above riches; and always live *within* his income. By studying the interests of his employees, he is promoting his own as well; and so with the journeyman; no journeyman ever lost anything in being faithful to his boss's interests. Mutual forbearance on the part of all, and a struggle to do what is right, is sure to end in success, happiness, and a competence.

#### CARRIAGES AND THE REVENUE TAX.

OUR former article relating to this subject, found on page 181, Volume IV., was written before the law came into operation, and before its effects on carriage-making could be seen. Instead of a simple tax of three per cent on the profits, we are compelled, monthly, to pay to the collector three per cent on the gross amount of sales made each month, which percentage, taken in connection with the tax previously charged to us by the manufacturers of axles, springs, cloths, carpets, silks, paints, varnishes, &c.—in fact, almost everything that enters into the construction of a carriage—swells the direct tax laid upon our productions to as much as six per cent, at least. Some articles are taxed two or three times over before we receive them; and it is questionable whether we ought not to be relieved under an amendment act passed March 3, 1863 (§ 30,) wherein it is stated that “articles manufactured from materials already taxed, or exempt, when the increased value of the manufactured article does not exceed five per cent, ad valorem, are exempt from taxation as distinct manufactures.” At any rate, we know that it requires a very large capital in these times to carry on a small business, and that the profits are likewise small.

When carriages are sold at a distance from the place of manufacture, by a commission agent, it has been decided that, “from the gross amount of such sales, there may be deducted freight, storage, insurance, and commissions actually paid; allowances to be made for the expenses of sale, not exceeding the usual commission upon the same or similar articles at the place of sale,” or five per cent on valuation, and this tax is due and must be paid as soon as the article is sent out of the manufacturer's district. Should the carriage afterwards be sold at a lower price than the estimate for taxation, no abatement under any circumstances will be allowed.

Repairs to old carriages or alterations on new ones after sale are not subjects of taxation, according to the late decisions of Commissioner Boutwell. Some of the collectors of this city, however, where robbery under the *color* of law is practiced as an honest occupation, have insisted that a tax must be paid monthly on the gross

amount of work done, which included new and old indiscriminately. Such an instance has come to our knowledge recently, and was practiced upon a manufacturer *too poor* to subscribe to this journal. How much he has gained by the want of our advice he, undoubtedly, has already discovered; but we fear there are many more of this “penny wise and pound foolish” class, paying dear for *their* “whistle.”

The amendatory act of March 3d, 1863 (§ 30), exempts spokes, hubs, and felloes from the tax, yet, with a disposition “to follow suit,” the manufacturers are talking about raising the prices, and, in anticipation of such rise, we have already been notified by the wheel-makers that they have added \$2 per set to their former prices. We believe we have now noticed about all the changes made in the tax bill since our last reference to the subject, as far as they affect the carriage manufacturer. How the original framers of the law came to associate our useful and beautiful productions with such *useless* articles as billiard-tables, yachts, &c., is a mystery. The association is quite bad enough without having to pay for the *relationship* at so costly a figure. The prices carriage making materials have reached may be learned from our table on the last page of this number.

#### PICTURE ADVERTISING.

EVERY expedient has been adopted by business men of the present day in order to draw attention to some special department of trade. The expense to which some individuals have gone in getting up show-bills would have frightened even the wealthier portion of our ancestors, and, with their accustomed thoughtfulness, led them to decide that “it wouldn't pay.” But the motto, “nothing venture, nothing have,” seems to have found scores of believers, as well as actors, for one can scarcely enter a public-house, a ferry-boat, or a rail-car, now-a-days, without finding them thrust before his eyes, and in such an attractive and *bewitching dress* that he cannot possibly refuse reading them. But we are digressing.

What we intended to introduce to the reader, when we began this article, was the very fine picture just published and sent to this office by our Broadway friends, Messrs. Brewster & Baldwin, carriage-makers. The picture presents life-like portraits of celebrated horses, such as Lantern, Flora Temple, Lady Palmer, the Flatbush Mare, Lancet, Prince John, New Jersey, and Brown Dick. Upon the back of the last named sits a jockey “as is a jockey” contemplating the field, over which the Lady Palmer and the Flatbush Mare are hurrying a “trotter” at a fearful rate—how fast, we leave to *the fancy* to decide. The artist, by placing Lancet and Brown Dick in the foreground, in contrast with the rest, has very efficiently and judiciously arranged the lights and shades



nature has supplied, so that the *tout ensemble* presents the eye with one of the most effective pictures yet produced for coach-making advertising. Some persons may question the propriety of getting out a picture filled with horses exclusively, but this is merely a matter of taste. In this instance there is, doubtless, an object in view. The horses represent those owned by their friends, and they have taken this mode of *hinting* that they are prepared to supply the carriages to all who are in want of such pleasurable property.

#### FOREIGN IMPROVEMENT IN CARRIAGES.

IMPROVEMENT IN HARNESS AND THE SHAFTS OF CARRIAGES.—J. M. Carter, the patentee in England, claims, *First*, The attachment of the ends or points of the shafts to the frame or other receptacle fastened on to the collar, or other breast part, as also the method set forth for regulating the length of the shaft. *Second*, Dividing a portion of the shaft lengthwise and having an opening in the same for admitting the tug. *Third*, The attachment of the surcingle to the under part of the tug. If a bar within the tenett with an opening, or a tenett which has an opening, and the height of the interior of which, or that part intended for the reins, is less than the width of the reins. *Fourth*, A receptacle for that portion of the shaft straps which support the traces in double harness, which is surplus caused by the action of the horse.

IMPROVED APPARATUS FOR MEASURING DISTANCES TRAVELED BY WHEEL-CARRIAGES.—This patent was taken out May 5, 1861, by J. A., in England, and the odometer is made in various forms. In the most complete instrument the patentee shows the termination of each mile by the sudden projection of a pin, stud, or other indicator on the face of the instrument, so that it shall be readable by the touch when it cannot be seen, the total distance being registered on a dial. In another arrangement is shown the distance by hands on a dial only, and the apparatus is also capable of being made both in form and size to resemble a watch. The indicator may be fixed in any part of the carriage, or held in the hand without interrupting the action of the instrument. The indicating portion of these instruments he connects with the driving part of carriage wheels by an air tube, and actuates them by a stud or other projection fixed to the hub, which, at every revolution, brings it into contact with the driving part of the apparatus, which he calls the blower. This is fastened to the axle-tree of the vehicle, and forces the air through the connecting tube into the air chamber of the indicator, and so gives motion to that part of the instrument.

CONCEALED FOLDING STEP.—On the 16th of May, 1862, F. Stoeken, in England, patented a folding step for carriages, made as follows:—An opening is made through the side of the carriage, by preference into the boot,

or that part of the carriage body over the fore wheels. This opening is closed by a door or panel, hinged to it at its under side, and this panel can be turned down so as to stand at right angles to the side of the carriage. The folding steps are connected to the upper part of the door or panel, and when the panel is turned down so as to be at a right angle to the side of the carriage, the steps may be turned down, and made to descend to any desired distance. When the steps are folded up, the door may be closed, and the carriage have the appearance of an ordinary vehicle.

IMPROVEMENT IN MAKING WHEELS.—May 22, 1862, J. Oxley of London, took out a patent for improvements in the preparation, by mechanical means, of the parts of wheels, by which is insured perfect accuracy of fitting, when the parts are put together, and the perfect maintenance of the parts in their proper form when finished by preventing injury to the spoke, tenons, and other joints; also, to the machinery for the production and multiplication of certain parts of wheels, and for their reproduction according to prearranged scales of proportions and dimensions. The improvements in the treatment of the felloe pieces of wheels consists in the accurate thicknessing to a gauge of each piece, by operating on the two sides at the same time, and this is effected by passing the piece of material to be operated upon between two revolving discs having cutters mounted therein. The machine for thicknessing or planing felloes consists of a bed or gantry, having two movable head-stocks thereon, and a traverse table, upon which is mounted the carriage and means of holding the piece of material to be operated upon. Each head-stock carries a revolving spindle or shaft, with an overhanging disc, containing one or more adjustable face cutters or chisels, between which the material is made to pass, and by which it is to cut. The distance between the cutters is capable of adjustment by reason of the movements of the head-stocks, according to the thickness to which the material has to be gauged. Each part of the machine is capable of accurate adjustment and regulation. For the purpose of insuring accuracy in the after processes of preparing the felloes and other pieces of the wheel, each felloe piece, having been examined by the workman, has two gauge points or center marks impressed upon one face, so that between those gauge points certain gauge holes are bored or drilled in a machine designed for that purpose; a central hole is drilled, of a depth of say  $1\frac{1}{2}$  to 2 inches, and on each side of such hole another gauge hole of lesser depth (say  $\frac{1}{2}$  inch to  $\frac{3}{4}$  inch deep) is made. By these holes the materials are accurately applied and adjusted in the various machines in which the subsequent operations are performed, by which means accuracy of reproduction is secured. For the purpose of boring and mortising with greater accuracy and rapidity the hubs of wheels for re-

ceiving the tenons of the spokes at any required angle with the central axis of the hub, and insuring that any number of hubs for a given size of wheel may at any future time be produced as identical counterparts of hubs previously made, the two operations of boring and mortising are performed without the necessity for removing the nave from the axis, shaft, or spindle by which it is caused during the operation, and without removing it from the compound machine. The carriage upon which the hub is mounted for the purpose of being operated upon, is capable of being adjusted in relation to the vertical sliding or revolving tool, and the exact angle desired may be obtained and recorded on a scale by means of a pointer arm.

For the purpose of forming a more perfect wheel, the patentee cuts an armular groove or recess within the hub, for the purpose of inserting a ring or collar of leather or other material, upon which the inner ends of the spokes will take their bearing, and thus forms an elastic bed or cushion between the ends of the spokes and the iron axle-box, and by which means a nearly noiseless wheel will be produced.

#### EDITORIAL CHIPS AND SHAVINGS.

**SLEIGH-DRIVING IN RUSSIA.**—Sleigh-driving is the one grand, unapproachable, unalloyed pleasure to be enjoyed in Russia. There is nothing to compare to a long, furious sweep in a good Russian sleigh, over hard, crisp, clean snow, wrapped in good furs. With a great bear-skin hanging over the back of the sleigh, and its apron, another bear-skin, covering your legs; with your feet incased in fur goloshes, resting on a doubled-up Siberian curly sheep-skin; with fur cap on your head, as tall and straight and round as a very large English hat without a rim; with your hands buried four inches deep among the sable sleeves of your coat; as you lie easily back, thus comforted, under a clear, frosty, bright sky; the horses, in graceful, silver-mounted harness, tossing their heads; the bells at their necks tinkling merrily; the driver in high wolf-skin cap and sheep-skin coat, over which he has drawn a handsome blue caftan trimmed below the arms with silver-plated round buttons as large as little eggs, and with a large, party-colored sash bound round his waist—a fellow all excitement, but coolly managing three wild horses who tear on at whirling speed, dashing the crisp snow in showers from their hoofs, sometimes for a moment or two half blinding you with the finest, cleanest, whitest powder in the world; with these appliances, and you see and feel them all, you know the luxury of sleigh-driving. I am not speaking of a drive through the streets of Petersburg, but of a drive of thirty or forty miles over untrodden virgin soil, through the forest, when the trees are clothed in a dense fantastic foliage of hoar-frost festooned with millions of stalactites, and when the bracing air, as you rush through it, sends the blood tingling through your veins.

**POWER APPLIED FOR.**—The London authorities have given notice of an application to Parliament for power to regulate the routes by which public vehicles plying for hire shall travel and to regulate the speed of the carts

and wagons with merchandise through the streets; define how long they shall stop to load and unload, and how long they may remain in one place; how high the loads may be piled; the breadth between the outside of the wheels; the maximum width of the load; the particular streets and lanes through which they may be allowed to pass; the time of day in which carts laden with timber, scaffolding, &c., over twenty feet in length, may pass; to regulate the mode of distinguishing cabs or hacks when empty, and to regulate the manner in which barrows, trucks, and hand-carts may be driven or wheeled on particular days in particular streets, and the making of laws imposing penalties.

**WHO ARE NATURE'S NOBLEMEN?**—Not those who, brought up in the lap of indolence, are dissipating the earnings of their fathers and relatives without laboring or doing anything themselves; they are the toiling millions, the laboring classes of mechanics, artists, inventors, farmers, &c.; these are the "upper circle," in the order of nature, whatever the factitious distinctions of fashionable society may claim. Can there be anything seen more noble than a poor man carving his way to competence by the toil and labor of his own hands? We think not, and have only scorn for the drones of society who are hugging the empty delusion that they alone are "the upper classes."

**NAILS—WHY CALLED SIXPENNY, &c.**—They are so called because they used to be sold in Sheffield, Eng., by the hundred, and the terms fourpenny, sixpenny, &c., designated such nails as were retailed at fourpence, sixpence, &c., per hundred nails. The length of the nails then made were exactly the same as made now and thus designated.

**COMPOUND TIRE FOR CARRIAGES.**—Our readers will have noticed an article of this kind advertised by Messrs. Bouton & Smith, on the cover of this Magazine, which is highly recommended by the leading coach-makers. The low price at which it is sold must make it an object to try it.

**CATALOGUES OF THE INTERNATIONAL EXHIBITION.**—Our thanks are due to the Messrs. Brewster & Co. for copies of the catalogues published by the United States' Commissioners at the International Exhibition, and also for those of Her Majesty's Commissioners of the Fine Art and Industrial Departments. These contain a fund of information which renders them valuable as books of reference. We have already noticed the awards made to our friends, the Messrs. Brewster and Co. An extract from the catalogue will give our readers some idea of the character of the successful vehicles: "The road wagon, or light buggy, as it is termed, is of the true Yankee style, weighing but about 170 pounds, and yet of such materials and workmanship as to be safe and reliable, as well as durable for years, for ordinary loads (two men) on common roads. The phaeton is built for four passengers, is remarkably strong for its weight, and very beautiful in its proportions. The award of the prize medal [a bronzed one, given '*honoris causa*'] to the Messrs. Brewster & Co., is for good construction, good workmanship, especially as to varnishing and leather work." In one of the volumes we find a complete list of the European carriages in the exhibition, but we cannot at present find room to reprint it.

**THE LIGHTEST YET.**—We have been shown, at Messrs.

Brewster & Co.'s, a skeleton wagon, weighing only sixty-eight pounds four ounces, including the shafts. Is not this the lightest yet?

### LITERARY NOTICES.

OUR special favorite, the *Atlantic Monthly*, for April, comes to us filled with the choicest literary dainties. In spirit it is decidedly loyal and patriotic, and in these times this fact alone should endear it to every true lover of his country. Among the varied contents is a beautiful poem on "The Flag," by Mrs. Howe, which alone is worth the cost of an entire copy. "No Failure for the North" is the title of another article full of encouragement and hopeful. We regret that we cannot find space to enter more fully into a review of the work, but advise our friends to buy it and read for themselves.

"*A Hand Book of the U. S. Tax Law*," has been presented to us by the publishers, Messrs. Baker & Godwin. This edition is superior to all others, not only giving the law and all the late amendments properly arranged, with a view of economizing time, but likewise presenting the reader with the Commissioner's late decisions in special cases, explanatory notes, &c. 12mo, 300 pp., \$1.25.

[Reported expressly for the New York Coach-Maker's Magazine.]

### AMERICAN PATENTED INVENTIONS RELATING TO COACH-MAKING.

Dec. 23, 1862. IMPROVED HOLD-BACK FOR CARRIAGES.—H. A. Harris, Battle Creek, Mich.: I claim the use of a graduated bar in combination with a movable stirrup or ring and a spring, for the purpose and substantially as set forth.

January 20, 1863. IMPROVED CARRIAGE HUB.—Charles Leavitt, Cleveland, O.: I claim the cap, I, shoulder, I', chamber, J, and hole, L, when combined with the pipe-box, B, all the parts being arranged and operating as and for the purpose herein set forth.

BRAKE MECHANISM FOR CARRIAGES.—Lowell Wilber, Putney, Vt.: I claim the application or arrangement of the slide-bar, G, its spring, H, chain, b, and pulley, c d, relatively to the perch, EE', and the rocker-bar, C, the front axle, A, and the tongue, J, provided with a draft-rod, I, operated by the chain, f, connected with the yoke or bar, L, and going around a pulley, e, as described.

IMPROVED AXLES.—Harmon G. Weibling, Denver City, Colorado: I claim the peculiar construction of my axle-boxes or thimbles, with the flanges, H R, oil chamber, F, and aperture, Z, when connected with a spiral groove, terminating in a canal in which are placed friction rollers, e, the whole combined and operating as described.

IMPROVED CARRIAGE-WHEEL.—Harmon S. Weibling, Denver City, Colorado: I claim my peculiar method of constructing the axle boxes or thimbles, and attaching them to the axles by means of the gutta-percha packing, A, and screws, when the boxes or thimbles are made to taper as described, having a canal lined with Babbit's metal, in which rollers, e, are placed, the whole used in construction with the strap, d, on the underside of the axle, and the bolt, j, the friction rollers, spiral groove and lubricator, all as described and set forth.

27. IMPROVED AMBULANCE.—Morriz Pinner, of New York City: I claim, *First*, the combination of a cooking-stove with the body of a wagon, arranged and operating for use as an ambulance and kitchen, substantially as set forth and described. *Second*, the combination of a cooking-stove with water tanks and a wagon, arranged for use as an ambulance or locomotive kitchen, either separately or combined, substantially as set forth and de-

scribed. *Third*, an ambulance, a medicine chest, a wagon, compartments for storing provisions, a cooking-stove, and a baking-oven, the whole arranged and operating substantially as set forth and described.

Feb. 10, 1862. IMPROVED METHOD FOR ATTACHING SHAFTS AND POLES TO CARRIAGES.—James Northrop, Zachariah Loomis, and Giles W. Clark, Homer, N. Y.: We claim the arrangement and combination of the double and single clip-bars, c, and d d, with the corresponding depressions in each, and when the single bar is made whole and connected with the double clip, and with the T-headed shaft or pole-iron fitting and working in said depression as and for the purpose above described.

IMPROVED METHOD OF CONNECTING SHAFTS OR THILLS TO SLEIGHS.—Jacob C. Walter, Leonardsville, N. Y.: In combination with the mechanism or its equivalent for changing the relative position of the shafts or thills, laterally: I claim the devices or their equivalents for changing or setting the thills forward or back, substantially as described.

IMPROVED CARRIAGE SPRING.—William Wharton, of Birmingham, England: I claim a combination of spring plates secured together, or embedded with each other by the peculiar form or forms of the edges thereof, such plates not being dependent on slots and pins or studs to secure them in position laterally, essentially as hereinbefore described.

17. IMPROVED CLASP FOR HARNESS TUGS.—L. D. Cowles, of Armada, Mich.: I claim the two plates, A F, in combination with the lever plates, E E, provided with the eccentrics, c c, and connected with the plate F, through the medium of the screws, C, and rods, D, all arranged substantially as and for the purpose herein set forth.

IMPROVED BENCH PLANE.—Seth C. Howes, of South Chatham, Mass.: I claim the rod, F, having the screw, d, cut upon it, and provided with the nut, E, with spurs, b, on its outer surface to fit in holes in the plane-iron, C, in combination with the cap, D, provided with the screw, K, and trunnions, e e, the latter being fitted in adjustable bearings, f f, which are placed in slotted plates, J J, and retained therein at the desired point by the serrated edges of the bearings, and the slots, or any equivalent means; all arranged substantially as set forth.

24. IMPROVED CALASH OR FOLDING-TOP FOR CARRIAGES.—Ira Cogswell, Jr., of Earlville, Ill.: I claim the combination of the inclined arms, E E, hooks, K, and folding bars, F F, with the bars, I J, bows e e' e'' e''', and seal, B, all in the manner herein shown and described.

IMPROVED COMPOSITION FOR LUBRICATING WAGON AXLES, &c.—James P. Gay, of Cincinnati, O.: I claim the improved tar herein described, consisting of the ingredients specified, combined substantially in the manner and in the proportions herein stated.

Mar. 3. IMPROVED SPOKE MACHINE.—Eli K. Wisell, Warren, O.: I claim, *First*, cutting the spokes in longitudinal sections by means of a revolving cutter and a traversing motion of the spoke and pattern, and the rotation of the spoke and pattern by sections in concert with each other, in the manner specified. *Second*, I claim the roller, K, upon which the pattern rests, for the purpose specified. *Third*, I claim the inclined planes, J J', in combination with the pawl and ratchet, I I, when arranged and operating as and for the purpose specified. *Fourth*, I claim the finger, P, and rod, T, when arranged and operated as described, for throwing the traverse frame out of gear. *Fifth*, I claim the traverse frame, D, and mandrels, F F, and e e', in combination with the revolving cutters, arranged and operating as set forth.

IMPROVED MACHINE FOR TENONING SPOKES.—H. M. Preston (assignor to A. H. Baker), of St. Louis, Mo.: I claim the employment of the cam, F, arranged upon the cylinder, E, or its equivalent in effect, in such manner as to impart to the cutter a reciprocating motion, in combination with its rotary motion, for the purpose of forming oval or flattened tenons for spokes of wheels, substantially as herein set forth and represented.

## CURRENT PRICES FOR CARRIAGE MATERIALS.

NEW YORK, April 10th, 1863.

Apron hooks and rings, per gross, \$1.25.  
 Axle-clips, according to length, per dozen, 50c., 63c., and 75c.  
 Axles, plain taper, from  $\frac{3}{4}$  to 1 in., \$5;  $1\frac{1}{2}$  in., \$6;  $1\frac{3}{4}$  in., \$6.50.  
 Do. case-hardened, half-patent, \$7; do. \$8; do. \$8.50.  
 Bands, plated rim, under 3 in., \$1.50; over 3 in., \$1.75.  
 Do. Mail patent, \$2.50.  
 Basket wood imitations, per foot, 85c.  
 ☞ When sent by express, \$2 for a lining board to a panel of 12 ft.  
 Bent poles, each \$1.  
 Do. rims, under  $1\frac{1}{2}$  in., \$2 per set; extra hickory, \$2.50.  
 Do. seat rails, 44c. each, or \$4.50 per doz.  
 Do. shafts, per pair, 75c.; bundles, \$4.50; extra, \$5.50.  
 Bows, per set, light, 75c.; heavy, \$1.  
 Bolts, Philadelphia, per gross, as per printed list.  
 Do. tire, 95c. a \$1.10, a \$1.80, according to size  
 Buckram, per yard, 18c. a 28c.  
 Buckles, per gross, 88c. a \$1.25.  
 Burlap, per yard, 25c.  
 Buttons, japanned, per paper, 15c.; per gross, \$1.50.  
 Carriage-parts, buggy, carved, \$3.50.  
 Carpets, Brussels, per yard, \$2; velvet, \$1.75; oil-cloth, 44c. a 50c.  
 Castings, malleable iron, per lb, 12c.  
 Clip-kingbolts, each, 25c.  
 Cloths, body, \$2 a \$3.50; lining, \$2 a \$3.50. (See *Enameled*.)  
 ☞ A Union cloth, made expressly for carriages, and warranted not to fade, can be furnished for \$2 a \$2.25 per yard.  
 Cord, seaming, per lb, 25c.; netting, per yard, 5c.  
 Cotelines, per yard, \$3.50 a \$5.  
 Curtain frames, per dozen, \$1 a \$1.50.  
 Do. rollers, each, 75c. a \$1.  
 Dashes, buggy, \$1.75.  
 Door-handles, stiff, 50c. a 63c.; coach drop, per pair, \$2 a \$3.  
 Drugget, felt, \$1.62.  
 Enameled cloth, 4 qrs. wide, 90c.; 5 qrs., \$1.15; 50 in., \$1.50.  
 Felloe plates, wrought, per lb, all sizes, 14c.  
 Fringes, festoon, per piece, \$1.75; narrow, per yard,  $12\frac{1}{2}$ c.  
 ☞ For a buggy top two pieces are required, and sometimes three.  
 Do. bullion, per yard, 31c. a 37c.  
 Do. worsted carpet, per yard, 6c. a 10c.  
 Frogs, 38c. per pair, or \$1.63 per dozen.  
 Glue, per lb, 25c.  
 Hair, picked, per lb, 50c.  
 Hub-borers (Dole's) for light work, \$15; heavy, \$18 a \$20.  
 Hubs, light, morticed, \$1; unmorticed, 75c—coach, morticed, \$1.50  
 Japan, per gallon, \$4.  
 Knobs, English, \$1.38 a \$1.50.  
 Laces, broad, silk, per yard, 55c. a 65c.; narrow,  $7\frac{1}{2}$ c. a 10c.  
 Do. broad, worsted, per yard, 25c. a 31c.  
 Lamps, coach, \$14 a 18.  
 Leather, dash, 25c.; slit do., 15c.; enameled top, 25c.; harness, per lb, 37 a 40c.; flap, per foot, 15c. a 18c.  
 Linen, heavy, a new article for roofs of coaches, 70c. per yard.  
 Moguet,  $1\frac{1}{2}$  yards wide, per yard, \$5.  
 Moss, per bale, 10c.  
 Mouldings, plated, per foot, 12c.; lead, door, per piece, 30c.  
 Muslins, per yard, 20c. a 35c.  
 Nails, lining, silver, per paper, 6c.; ivory, per gross, 25c.  
 Name-plates.  
 ☞ See advertisement under this head on 3d page of cover.  
 Oils, boiled, per gallon, \$1.50.  
 Paints. We quote white lead, extra, \$3.50; Eag. pat. black, 25c.  
 Pekin cloth, per yard, \$2.  
 ☞ A very good article for inside coach linings.  
 Plushes, per yard, \$2.  
 Pole-crabs, silver, \$5 a \$6; tips, \$1.  
 Rubbing stone, per lb, 12c.  
 Screws, gimlet.  
 ☞ Add to manufacturer's printed lists 15 per ct.  
 Do. ivory headed, per dozen, 38c. per gross, \$4.  
 Sand paper, per ream, \$3.50.  
 Scrins (for canvassing),  $11\frac{1}{2}$ c.,  $12\frac{1}{2}$ c.,  $13\frac{1}{2}$ c., according to quality.  
 Shaft-jacks (M. S. & S.'s), light, \$2.50; heavy, \$2.75.  
 Do. tips, extra plated, per pair, 31c.  
 Silk, curtain, per yard, \$1 a \$2.25.

Slat-irons, wrought, per pair, 55c.  
 Slides, ivory, white and black, per doz., \$6; bone, per doz., \$1.50;  
 No. 18, \$1.75 per doz.  
 Speaking tubes, each, \$4.50.  
 Spindles, seat, per 100, \$1.  
 Spring-bars, carved, per pair, \$1.  
 Springs, best temp. per lb, 23c.; black, 20c.  
 ☞ Two springs for a buggy weigh about 28 lbs.  
 Spokes, buggy, per set, \$3, or about 5c. each for all under  $1\frac{1}{2}$  in.  
 ☞ For extra hickory the charges are  $6\frac{1}{2}$ c. each.  
 Steel, Farist & Co.'s Homogeneous American, per lb, 16c.  
 Do. English Homogeneous, do. 20c.  
 Do. Compound tire, do. 7c.  
 Stump-joints, per dozen, \$1.25 a \$1.50.  
 Tacks, 5c. and upwards per paper.  
 Tassels, holder, per pair, 63c. a \$1; inside, per dozen, \$3; acorn trigger, per dozen, \$1.25 a \$1.50.  
 Terry, per yard, \$7.  
 Top-props, Thos. pat., per set, 35c.; plain, com., 35c.  
 ☞ The patent props, with silver-plated nuts, per set, 75 c.  
 Tufts, ball, per gross, 50c.; common worsted, 12c. a 25c.  
 Thread, Marshall & Co.'s Machine, No. 432, \$2.40 per half lb; No. 532, \$2.75 do.; No. 632, \$3.50 do.  
 Turpentine, per gallon, \$3.50.  
 Twine, tufting, per ball, 25c.  
 Varnishes (Amer.), crown coach-body, \$4.50; hard drying, \$5 nonpareil, \$5.  
 Do. English, \$9 a \$9.58.  
 Webbing, per piece, 44c.  
 Whiffle-trees, coach, turned, each, 25c.; per dozen, \$2.50.  
 Whip-sockets, rubber, per dozen, \$7 a \$9; pat. leather, stitched, \$3.  
 Yokes, pole, each, \$1.  
 Yoke-tips, 50c. a 75c.

We intend to enlarge and correct this list monthly, so as to enable those who commission us to make their purchases to ascertain by computation about the amount they require to remit us. This should be done, if a large sum, by draft to our order in New York, or if small, in a registered letter to our address. We will furnish these goods at a reduction on large orders. None but cash orders filled, and where C. O. D. bills are forwarded with the goods by express, charges for collection must be added, which amount in ordinary cases to from 25c. to \$1, according to distances. All this may be saved by sending us the money with the order. Please read notice of "General Business Agency," on 3d page of the cover, in connection with the above.

## TO READERS AND CORRESPONDENTS.

BACK VOLUMES of this work will be sold, in numbers, for \$3; when bound, for \$3.50, to which, if sent by mail, 48 cents must be added to pre-pay postage; if two or more volumes are called for at one time, they can be had for \$3 each, or will be sent by express, at the purchasers' expense, at the same price. The subscription to the Fifth Volume, now in course of publication, will be (in consequence of the advance in paper and printing) four dollars, IN ADVANCE, for the twelve numbers; and these will be issued, in 1863 for Jan., March, May, July, Sept., Nov., Dec., and afterwards monthly until the close of the volume in May, 1864. Should the war end, and business again resume its natural channel, we intend to resume and publish monthly, as formerly, the Sixth Volume in June, 1864. Any of the old numbers can be had for 30 cents each; the new numbers will be 35 cents each. It will thus be seen that we give our friends the benefit of low prices for old stock, and we trust they will allow for the necessity which compels us to charge an advance on our present issues, for the reasons above stated, while the present exigencies continue.

COVERS, handsomely gilt, and ready for binding the numbers therein (which any binder will do for 35 cts.), can be had at this office for 54 cents. When mailed (the postage on which we prepay), 66 cents. Any volumes left with us will be bound for \$1 each in our uniform style. This advance is caused by the rise of book-binder's material.

AGENCY.—Our friend Mr. Henry Harper, who is traveling in the West, is authorized to take subscriptions for us, and receipt for moneys paid; and any contract he enters into concerning this Magazine will be honorably carried out by the Publisher. In Canada West, Messrs. McKinley, Cowles & Co., at St. Catharines (dealers in carriage-hardware), will act as our local agents.





SOCIABLE WAGONETTE.— $\frac{1}{2}$  IN. SCALE.

*Designed expressly for the New York Coach-maker's Magazine.—Explained on page 55.*

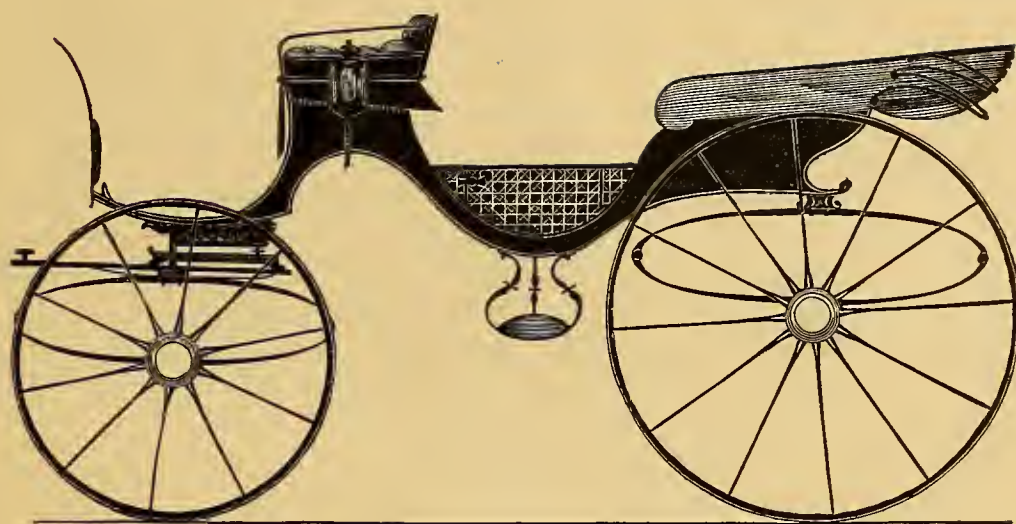

PHAETON FOR FOUR PASSENGERS.— $\frac{1}{2}$  IN. SCALE.

*Engraved expressly for the New York Coach-maker's Magazine.*

*Explained on page 55.*







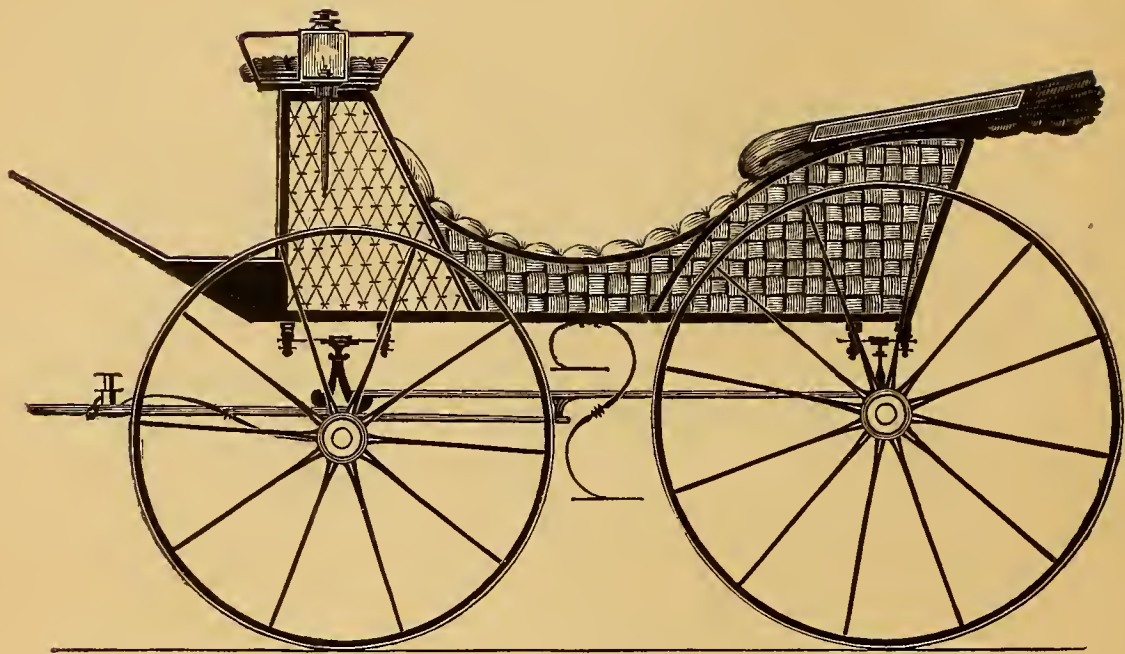

BERLIN SPORTING WAGON.— $\frac{1}{2}$  IN. SCALE.

*Engraved expressly for the New York Coach-maker's Magazine.*

*Explained on page 55.*

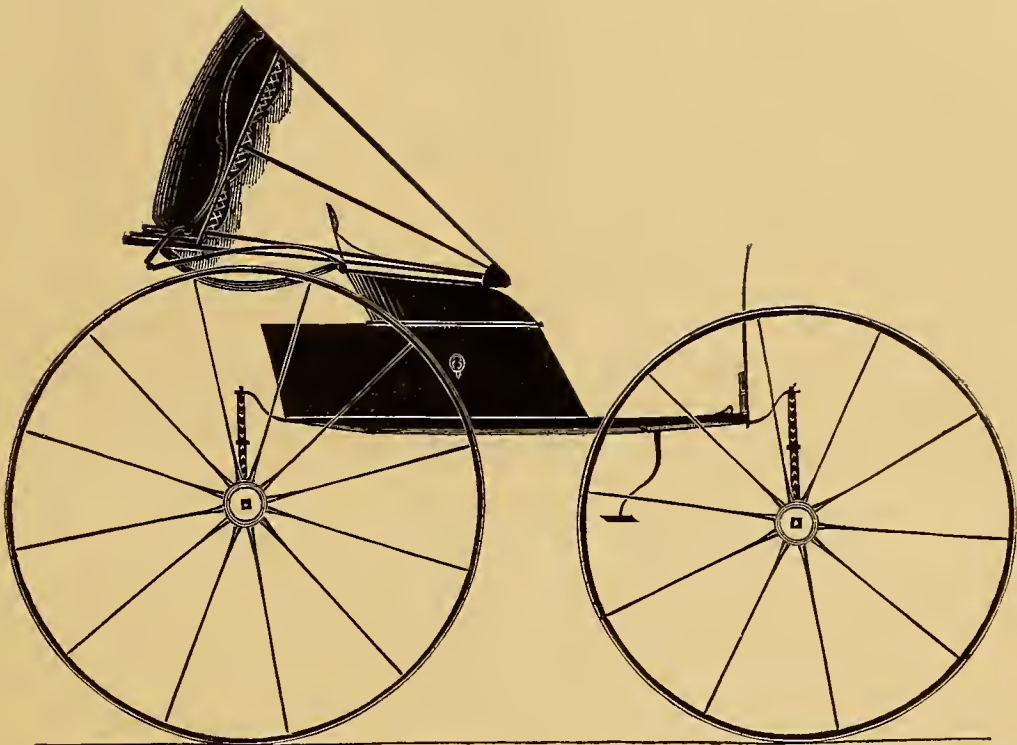

THE COAL-BOX BUGGY.— $\frac{1}{2}$  IN. SCALE.

*Designed expressly for the New York Coach-maker's Magazine.*

*Explained on page 55.*





DEVOTED TO THE LITERARY, SOCIAL, AND MECHANICAL INTERESTS OF THE CRAFT.

Vol. V.

NEW YORK, JULY, 1863.

No. 4.

### Mechanical Literature.

#### THE MOTIVE-POWER OF WHEEL-CARRIAGES.

BY H. H.

(Continued from page 38.)

HAVING viewed the subject under consideration as a lever power, subject to waste from various causes, we now come to the fourth and last cause which we proposed to discuss: that is, using material for the axle-box and arm which does not polish smooth, thereby creating unnecessary friction. By many this defect is considered the most prominent one against getting an easy running carriage. Although it is a serious defect, we do not attach so much importance to it as we do to distributing the bearings equally on both ends of the axle; for it will be seen that no quality of metal can be found that will resist the action of friction when this last condition of the bearings is not observed.

In the bearings of axles or shafts sustaining heavy loads, it has been found that iron or steel runs the best in a softer metal for the box than the shaft itself is made of. Hence has originated the composition for boxes or bearings known as Babbit, Copper, Brass, Composition, and other metals with which engineers are familiar, and all of which consist in putting a hard metal, of which the axle or shaft necessarily has to be made, on to a bearing of softer metal, such as are above enumerated. Although this may be practicable in cases of stationary machinery, where it can be protected from sand and other kinds of grit, yet it will not do for carriage axles and boxes for this reason: they are exposed to sand, which, when pressed between the axle and box, will partially indent itself into the softer metal, which supports the particle of sand firmly, so that it will cut a very minute particle out of the axle as the box revolves around the same.

As we have said before, speaking of these bearings (see page 17, Vol. V.), *heat is created by separating particles of matter, or, what is the same thing, friction of any kind.* The harder the metal from which these particles are separated, the greater amount of heat will be generated by that separation. We are, therefore, from necessity, in the case of carriage axles, compelled to put together two metals which are not the best adapted under

more favorable circumstances to run together. This can be safely done if we observe this all-important principle: to have the pitch given to the axle-arm so that the bearings will be equal at both extremities; but if this is not observed, no matter how much we may case-harden the axle-arm, it cannot be kept in that state, for it will heat and *cut-out* just as readily as if it were softer metal. When the bearings are made equal, there will always be a thin coat of oil, used for lubricating, spread between the two pieces of iron, so that it actually keeps them from touching each other to such an extent that there will not be any heat created. It is true that, in all cases of unpolished iron, there will be particles extend out from the general surface, which will become broken off so that they will create a smooth polish, but they are generally broken off so gradually that no great inconvenience from heat will arise to the axle; yet we almost instinctively look out for heat in new machinery until the process of breaking off these particles is completed and the machinery is polished smooth.

On the contrary, when the bearings are unequal at the two extremities of the axle-arm, the part that receives the greatest pressure will be liable, at any time when the pressure becomes too great, to crowd the oil out from between the two pieces of iron, so that the particles of iron come actually in contact with each other, and as they do so they interlock, and as one piece revolves around the stationary one, the motion breaks off the particles which are locked together. From this commences heat. It is well known how this heat extends to the connecting parts of iron, and destroys the oil which is used for lubricating. This occasions what we call "cutting out," which is, the box or axle becomes heated and softened, therefore the pressure easily removes the soft iron from its place, and sometimes wears out a box or axle in a few minutes. I have seen a case where the box and axle fused, so that they became partially welded, and were only with difficulty separated.

Not long since I called the attention of a friend to an axle that had been cut out and destroyed by heat. He thought that it must have been done by sand getting into the boxes; for it had the appearance it would have had if it had been scoured off by some very coarse and hard substance; yet it evidently was alone done by heat, as he himself finally admitted. If sand gets between the two hard metals of the axle and box, the grains will be

crushed again and again until they become so small that the particles thus divided are admitted within the space the oil alone should occupy, without crowding on either side. It is absolutely necessary for the axle and box to be hard enough for this crushing process; therefore the idea of lining boxes with copper, brass, or any soft composition, is wrong.

Since the article which appeared on page 17 of this Volume was written—accounting in the way it did and now does for heat being created by friction—another reason has been given, which, if correct, does away entirely with the arguments we have presented. As it comes from high authority, and is believed by many to be correct, it is necessary for us to notice it. It is given in the lecture of Professor Tindall, F. R. S., before the Royal Institution, London. The subject is, "On Force—Laws of Motion," and republished in the *Scientific American*. The Professor, with considerable ingenuity, endeavors to show that all motion is created by heat, and when that motion is suspended by a contrary resisting force, as it necessarily must be, the heat that put it in motion is generated, in the matter that has been suspended, back again to the body put in motion. He illustrates it by experiments of firing a cannon ball against a target, in which case it is found to be hissing hot after being stopped in its motion. Reasoning from unquestionable facts, he says, "that, if he drops a sphere of lead, weighing one pound, sixteen feet, it will, at the moment that its progress is suspended, have attained the velocity of thirty-two feet per second, and at the moment of being arrested would generate a quantity of heat sufficient to raise the temperature of its own mass three-fifths of a Fahrenheit degree."

So far he gets along very well with his analogous case; but the next sentence brings his argument to a dead set. He says that forty times that velocity would be a small one for a rifle ball, yet it would be sufficient when the ball hit a target to raise its temperature to 960°. This, he says, would be more than sufficient to fuse the lead; but he thinks in reality the heat would be divided between the target and the bullet—"nevertheless" (he says), "it would be worth while to pay attention to this point, and ascertain whether rifle bullets, under some circumstances, do not show signs of fusion."

Now this is making two assertions about the results of experiments, without the shadow of proof to confirm them; but, on the face of them, they have apparently a strong contradictory proof. Experiments show that many substances can be heated instantaneously, but when heat is once generated it cannot be destroyed or absorbed by other matter so instantaneously. For instance: if a globe of liquid lead is dropped on to any hard substance, that substance does not absorb the heat so that the lead becomes a solid mass instantly, but the lead flies in small particles over the surface of the solid substance. Now if there was enough heat generated by the bullet meeting resistance to fuse it, upon that instant the particles would fly asunder, instead of penetrating the solid substance. In the case of the globe of lead heating three-fifths of a degree by falling thirty-two feet, there can be no test applied to prove it, and to all appearance there is no change in temperature.

In the case of the cannon ball becoming hissing hot when forced against a target from the cannon, there can be no doubt of its being so; but we regard this as a strong proof of the assertion that we have made and still make,

to wit, that heat is generated by breaking off the particles of matter, which we call friction. When the ball is forced against the target with such tremendous momentum, the shape of it is changed by the shock, which is separating the particles of matter to make this change in the shape. The same phenomena will be observed by placing a small piece of iron on an anvil and striking it hard with a hammer. The shape is changed, and the iron is heated hot, but not the hammer, as Prof. Tindall's theory would have it. Repeated blows on the anvil with a hammer would heat both the anvil and hammer on the surface that became bruised, and no more. The same thing is observed in turning iron. The shaving cut off becomes heated. The same also is accomplished by scraping a steel across the sharp angle of a flint-stone. It takes off a fine shaving of steel, which becomes so heated that it ignites and burns up in the bright spark that it shows. The reason why hardened steel is better than iron to strike fire with, is because the harder the particles are to separate, the more heat is generated. Again, another reason is, that steel will burn at a much lower temperature than iron. This will be seen by dropping the filings from steel into a hot fire; they will ignite almost as quick as powder.

It is unnecessary to add proofs to show what we first stated, namely, that heat is generated by the breaking off of small particles from the surface of bearings, for every practical man who has had any experience in putting new machinery in motion knows how hard it is to keep that machinery from heating until the bearings become worn smooth, or, in other words, a regular surface is obtained. If it was the resistance to motion that created heat, why does it not continue after the bearings are worn smooth? The reason that we are led into arguing this apparently plain subject to this length is, that literary associations, which are probably *more literary* than practical, have adopted Professor Tindall's theory, which also seems to be a "pet" theory with one of our own scientific journals.

In a report of the proceedings of the "Polytechnic Association of the American Institute"—which will be found on page 356, Vol. VII., of the *Scientific American*—Mr. Fisher, in describing a shell lately invented in England, said, "the novelty about this shell was, that no arrangement was prepared for exploding the charge—it was fired by the concussion of the projectile as it struck." Mr. Dibon asks, "What, then, caused it to explode when it struck?" Mr. Bartlett replied, "This is one of the manifestations of the conservation of force. *The heat is generated by the destruction of motion. The mechanical force of motion is converted into caloric.*" If the mechanical force of this shell had been stopped by the atmosphere and gravitation, as it certainly would have been had it met with no other impediment, would Mr. B. think the same amount of heat would be generated? I do not think he would, yet to carry out the theory it should be so.

(To be continued.)

## REASONS FOR THE NECESSITY OF GATHER IN AXLES.

BY J. R. GATES.

IN a former article we discussed the dish of wheels, the taper of axles and their relation to each other, taking the wheel in a perpendicular position, and promised that

in our next article we would explain the horizontal line through the wheel, and its relation to the axle. In doing this we shall endeavor to be brief, but explicit. In this, as in all other scientific subjects, we must understand the objects to be attained, as well as the defects existing, before we can intelligently seek after a remedy. When we examine closely the motion of a wagon wheel on its axle, we find a difference between *that* motion and that of a pulley or spur-wheel in machinery. To illustrate this difference, let us take a wagon with tapered axles and place it on a smooth floor, and then take out the lynch-pins and (the axles being equally tapered on both sides) draw it forward by the tongue, and it will be found that a few revolutions will run the wheels entirely off the axles. Now place the wagon in the same position, and wrap a string around the front rims or tires, as a belt passes around a pulley in machinery, and draw the wagon forward by this device, and it will be found that while the hind wheels run off as before, the forward wheels will run up tight against the hurder or shoulder. The cause of this difference is simply the change in the application of the propelling force from the center to the periphery of the wheel. The reason of this difference might be mechanically explained, but would occupy too much space for our present purpose.

From this we see that the same rule that will avoid friction on a straight shaft, or spindle, in machinery, will not have this effect on a tapered axle when the power is applied at the center of the wheel. Therefore some change must be made in the taper of the axle to prevent the wheel from running out against the nut, or lynch-pin.



To accomplish this object (see Fig. 3), dress the bottom of the axle straight, and ascertain the difference of size there is between the but and point boxes; next, take all of this difference off the top of the axle point, as shown in Fig. 3; then divide this difference into three parts, taking two-thirds off of the back of the axle-point, and one-third off of the face, or front, as shown in Figure 4.



This will be found correct under all circumstances, and on all kinds of axles; for when the dish of the wheel is changed, the taper of the axle must also be changed; but their relative position to each other never changes, therefore this proportion of "gather" never changes. The reason why *exactly* one-third should be taken off the front and two-thirds off of the back is necessary, can be given, and mathematically explained; but, as it is not essential to our purpose, we shall omit it.

From all we have said we may sum up the rule for our guide in a few words. Always maintain the base of the axle straight; dish the wheel sufficient to bring the spoke perpendicular and at right angles with the case; then set the point of the arm forward until one-third of the taper is off the front and two-thirds off the back. When this rule is followed, the coach-maker will never hear of any cutting, or heating of the box, bad iron in the spindle, and other troubles complained of.

## ANCIENT ROMAN CARRIAGES.

BY THE EDITOR.

WHEN we gave the readers of this Magazine the series of chapters entitled "Coach-making Historically Considered and Incidentally Illustrated," in the first and second volumes, we omitted noticing in detail those vehicles more closely connected with Roman history,—as to have given them would have seriously broken the thread of our chronology. It is our design to supply this history, without strictly following chronology (as that is now impossible), in about four articles, for the present volume.

As among other nations, so in the earlier days of the Roman government, carriages appear to have been the offshoots of progressive civilization. Surrounded as the Romans were in part by the haughty and warlike States of Greece, which in the vortex of time were to be swallowed up by this mighty people, it would appear strange, indeed, did they not adopt such luxuries as their new dependents were possessed of.

We are told by Beckman, in his History of Inventions, that "the earliest Roman vehicle on record is the *arcera*,—a kind of covered cart, of which mention was made in the Twelve Tables." It was a covered carriage, used by sick and infirm persons. It appears to have been employed earlier than the more luxurious *lectica* (litter), and by it to have been brought into disuse. A later invention appears to have been the *carpentum*, or covered cart, used by the Empress Agrippina, the form of which is repeated in a different style of finish on antique Roman coins; but always with



an arched top or covering, said to have often been hung with costly cloth, and evidently profusely ornamented. We introduce several examples from an edition of *Suetonius*, in our library, printed at Basle, in 1675. The obverse reads, *Agrippinam, F. Mat. C. Caesaris Augusti*. These were nearly all coined in honor of some distinguished female, as appears from the inscriptions found thereon. *Honos carpenti, quo per Circum ducebantur matronae.*—*Suet. Claud. c. 11*. On no coin issued during the reign of Julius Cæsar does the *carpentum* figure, although there are several *quadriga* or chariots with four horses or elephants attached, and likewise some with two horses only. The *carpentum* is found on many later coins, represented with



both mules and elephants hitched four abreast. On one coin a hearse is represented, drawn by four horses, ornamented with four pegasus and several other winged figures.—*Suet., p. 283*. Livy tells us that the *carpentum* was used for carrying the Roman matrons in procession on funeral occasions; but this distinctive privilege

had to be obtained by special decree from the senate of Rome. This carriage usually had seats for two persons; but sometimes two seats were formed for the accommodation of a third person and the driver. Some of these vehicles were so luxuriously finished, and occupied by women, children, eunuch, and lazy men, that Juvenal found occasion for making the practice a subject of satire.

Praeter majorum cineres atque ossa volucris  
Carpento rapitur pinguis Damasippus, et ipse,  
Ipse rotam adstringit multo sufflamine consul:  
Nocte quidem; sed luna videt, sed sidera testes  
Intendunt oculos.—*Satire VIII.* 146.

Thus, literally translated: "By the ashes and bones of his ancestors the fat Damasippus is hurried in his rapid carpentum, and himself, himself a consul, locks the wheel with a long drag-chain: by night, it is true; but the moon sees, but the stars [as] witnesses, stretch their eyes [toward him]."

Carpentum seems to have been the generic term for different descriptions of covered vehicles. They were employed in various forms for town uses, traveling, and even for wedding occasions. On the night of a marriage the bridegroom bore away the bride from her father's house to his own dwelling. Seated on the right of his bride with a confidential friend on her left, the carpentum was driven through many of the public streets, the friends of the parties leading the way, while the servants and slaves followed after the carriage. From the windows the bridegroom scattered nuts among the spectators, shouting, "*spargere marite nuces!*"

Among the Romans a great difference prevailed in driving carriages, whether on special or ordinary days. The *carpentum pompaticum*, or State coach, was only allowed by the senate to such persons and their families as had gained distinction by their public actions for the good of the State; and the honor, on all public festivals, was strictly confined to such in the procession. While on ordinary days no particular rule was observed in public, and particularly in sacred, processions, no one was suffered to appear who had no right by law, and those who had the right were not allowed to drive in any vehicle unless sanctioned by custom. According to Tacitus, this custom or law continued for a long period, until the infamous and ambitious Messalina, the wife of Claudius Cæsar, regardless of the feelings of the Roman people, rode into the capitol on a carpentum. When afterwards ladies of distinction rode to the capitol in solemn procession, it was considered an act of pride and presumption.

The carpentum with four wheels—a rare thing—seems to have been exclusively used by emperors, princes, and the chief officers of State. They were seen at the circus festivals on opening days, bearing the lares and penates of this idolatrous people, among which they placed the images of deified Cæsars, many of which were devils incarnate, and guilty of the most revolting crimes known among men. Like the *pilentum*, of which we shall presently treat, the carpentum was usually hung on swing-poles, having higher wheels than the chariot, with wooden side panels two feet high. The entrance was at the back end of the vehicle, through a door hung upon hinges in the manner of some more modern carriages, fitted with a kind of lock to fasten it. Four carryatides (human figures), or other effigies, formed the pillars (see Figs. 1, 2), gilded, or else of ivory, gold, or silver, supporting the canopy or covering. This covering, as before mentioned,

was often a richly colored cloth, embroidered with silver or gold, or both, and overlaid with laminae or tiles; and sometimes the sides were enclosed with entire sheets of that metal. The interior trimmings were richly wrought stuffs, stuffed to make them soft, and the seat accommodated for reclining was trimmed with the same material, and embroidered with gold, silver, precious stones, and pearls. These seats were hung on straps to a cross-bar, the hanging straps which fitted flat to the sides of the body being fastened to straps which grasped the seat. A step facilitated entrance behind. From some examples it appears that windows at the side were often made in the carpentum. These, we are told, ran in grooves, and were raised or let down at the pleasure of the occupant. The *glasses* of these were made of talc, thin horn bleached, selenite, or moon-stone, serving as transparencies. These windows were finished with inside curtains, or blinds of painted linen, frequently embroidered. The back and front were furnished with appropriate curtains which could be drawn aside at pleasure.

(To be continued.)

## ON REPAIRING AND IMPROVING ROADS.

BY JOHN MEARS.

FRIEND STRATTON,—Being well aware of the lively interest you take in progressive carriage-building, I may tell you that I consider a superior carriage one of the finest exhibits of artistic skill, and it is pleasant to look at such in the salesroom, and to point out to a customer who can appreciate its merits, and is disposed to purchase it, at a fair price, all its beauties. I also like to enjoy the movements of a vehicle behind a well-harnessed team, on a smooth and well consolidated road. But where shall we find such a road? That is the question.

The mildness of the passing winter thus far is such that our roads have been, now are, and probably will continue to be, in a deeply rutted and corrugated state, by reason of excess of water, and the repeated coming out of the frost, rendering travel difficult while they are in this semi-fluid state; but the original material is about all there, although displaced, to be sure. How may the roads be restored to their former condition—smooth and solid? *The best way is as good as any.*

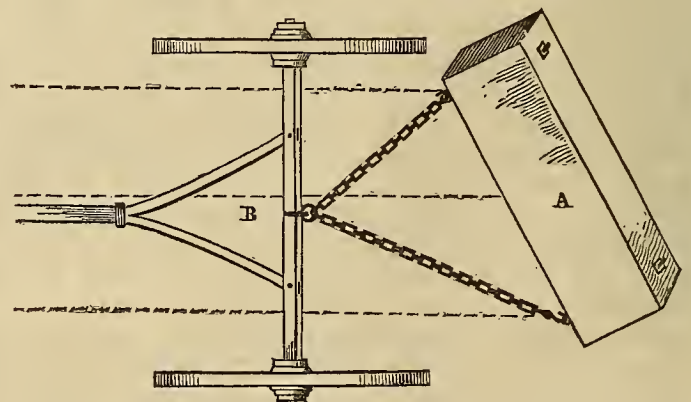

Having built, used, and seen the operation of a great variety of implements in repairing roads, such as harrows and scrapers—single and combined—rollers, drags, picks, hoes, &c., experience convinces me that the best instrument is a *rough ashler* or *split stone*, 4½ feet long, 1½ feet



wide, and 1 foot thick, weighing about 1,200 pounds. This should have two eye-bolts securely fastened into the side, about nine inches from the ends; or it may be strapped with old tire iron, with bolts to draw by. Into these hitch a draught-chain; take up the "bight" of the chain so that, when hitched behind the transom-bolt of the forward wheels of a farm wagon, the bridle arms shall be unequal, and the stone drawn at an angle of about 30 degrees' inclination to the center of the road. With a four-ox team—one man to drive, one to tend the stone, and one to pick off the stone and dress the road—start it over the off ruts, returning on the opposite side ruts. By this apparatus the ridges will be leveled, the ruts filled and consolidated, the small stones *ripped out*, and, together with the loose gravel passing along the front of the stone, will be left in the central *horse-gutter track* to be picked up and dressed off.

By this means four miles of road may be repaired in a day, putting it in better condition than roads I have seen where many dollars per rod have been expended. Now let us look at the cost: say, four oxen, \$4.00; four men, \$4.00=\$8.00, or \$2 per mile, which is about three-quarters of a cent per rod. The expense of the stone hoopings is about \$5.00. This stone will last for years, and makes a good door step at all times. Let every town procure five or six stones *forthwith*; try them as the frost leaves the ground and the roads are drying off; thereby the public ways and travel will be improved.

For a snow-path, take a cylindrical 10-inch peeled log, 8 feet long. At about 20 inches each way from the center, bore three 2-inch augur holes, so as to pass a draught-chain through, and fasten it across under the nose of a large farm-sled. Having a suitable team, with this track out and consolidate a path on which two sleighs can pass, and on which the women and children can travel with ease, for it will wear smooth, and last much longer than otherwise beaten out. If by these suggestions your vehicles shall be made to glide more smoothly, and meet with less obstructions, the Plow-maker will be gratified.

SOUTH ABINGTON, MASS., Feb. 13, 1863.

#### CARRYING THE MAILS IN OLDEN TIMES.

THE following is taken from the General Entries in the Secretary's Office at Albany, and is curious as noting one of the earliest posts in this country: "Whereas, it is thought convenient and necessary, in obedience to his Sacred Majesty's command, who enjoynes all his subjects in their distinct Colonies to enter into a strict Alliance and Correspondency with each other, as likewise for the advancement of Negotiation, Trade, &c., Civill Commerce, and for a more speedy Intelligence and Dispatch of Affayres; That a Messenger or Post bee authorized to sett forth from this City of New Yorke monthly, and thence to travaile to Boston, from whence within that month hee shall returne againe to this City. These are therefore to give notice to all persons concerned, That on the first day of January next, the messenger appointed shall proceed on his journey to Boston. If any, therefore, have any Letters or small portable goods to be conveyed to Hartford, Connecticut, Boston, or any other parts in the Road, they shall bee carefully delivered according to the Directions by a sworne Messenger and Post, who is purposely Employed in that Affayre. In the Interim, those that bee disposed to send Letters, let them bring them to

the Secretary's Office, where, in a lockt up Box, they shall be preserved 'till the messenger calls for them. All persons paying the Post before the bagg be sealed up. Dated at New York, this 10th day of December, 1672.

By Order of y<sup>e</sup> Governo<sup>r</sup>."

### Home Circle.

#### LIGHT FROM AFAR.

BY LUA DELINN.

THERE'S a light on my window glancing,—  
A light that falls from afar;  
I dream 'tis the dwelling of loved ones,  
That distant beautiful star;

And I ask, do they ever turn earthward  
Their eyes, with sorrowing gaze,  
To search out their missing dear one,  
And why she so long delays?

And can they mark my pathway  
From their radiant home afar?  
Do they see when its lights are gleaming,  
And how dark its shadows are?

O yes! for the starlight darkens,  
And now it begins to shine,  
As they sigh o'er my evil fortune,  
Or joy for the joy that is mine.

#### MYSTERIOUS KNOCKINGS.

BY ELIZABETH A. CHESTER.

KNOCKS, knocks, knocks—one, two, three—  
Knocks grow thick on every tree;  
Knocks are on the blockhead's noddle—  
The brainless dreams of knocking troubles.

THE days of miracles, it is said, are past. It may be so, but surely we are at the very noon-day of marvels. Idle girls, "misses in their 'teens," and rattle-headed schoolboys, by an occasional thump, cause the oldest eyes to stare, and maiden ladies to fancy that the end is just at hand, either of the world, or—of their days of maidenhood. The curious, the inquisitive, the slothful and the speculative—all who delight in something new, strange or mysterious—possessors of itching ears or busy imaginations—those desirous of seeing whatever is novel, and those who love to draw the curtain and peep behind the scenes of the unseen world—all, all, save the unfortunate few who are blessed with brains, are agog to know what it *can* mean.

Newspaper scribblers, those whose vanity is inflated by seeing their names or thoughts in print, suddenly discover themselves becoming persons of most amazing importance. Column after column is printed for the gratification of the gaping crowd, who still read, surmise, and exclaim with as great wonderment as if gazing into the very witch's caldron, where

"Bubble, bubble, toil and trouble,"  
For—blockheads stare and numskulls scribble.

One would suppose from the present noise and disturbance that such things as "knockings" had never before been heard in this little world of ours; yet some quarter of a thousand years ago, if we take Shakspeare's word for it, one, perhaps, of the very Rochester sisterhood

rhymed it after the above fashion. And down to our times there has been knockings gentle, and knockings loud—pretty, quiet taps, that come modestly to *ask*, and loud, clamorous rappings, which seem to *demand*, that the fastenings of your door be loosened. These may be in no degree mysterious in lands where the aristocratic spirit finds an abiding place; but in this country of title-abhorring and distinction-eschewing liberty—where the pure spirit of democracy dwells, and where no one can endure the thought of being seated one inch above his neighbor, or of being “Colonel-ed,” “General-ed,” or “Honorabl-ed”—here in this land of unambitious equality we have not yet reached the point of distinguishing a visitor by the knock of his footman; though there is a little, a very faint, distinction between the aristocratic and the plebeian rap,—a difference just enough to enable the initiated to conjecture whether the visitor be from Avenue No. Five, or its next neighbor, Avenue No. Six.

But, gentle reader, there are other knockings, not quite so physical or gross in their nature. There are, I think, those who, if they *would*, could tell us of knockings of quite another sort—of ideas, it may be mathematical, it may be philosophical, or perhaps ethical, that have knocked and knocked and knocked again at the doors of some of their minds, and gone away to report—“Nobody at home.”

And it has been suspected—of course, very much against the truth of the matter, or, if with any reason as to those of past generations, surely no sane man, or *half* sane woman, could suspect it of the present; yet as I was going to say, there have been idle surmises—that in a certain granite-fronted building in the good city of New York there have been certain young persons occasionally driven to rubbing and rapping their craniums to wake up if possible something having as much of the semblance of ideas as might suffice to blot and spoil a fair page. Inexorable teachers, it has been said, were there in the habit of exacting thoughts from the thoughtless, and ideas where Spurzheim, with ten fingers and a microscope, could never have found an apology for the bump of ideality. If there be truth in these tales, bottles of salt tears will witness against such cruelty. Dear schoolmate, what knockings we might have suffered had our lot been cast among taskmasters so unreasonable!

On the whole, this is a knocking world. Just see how men knock and jostle one another in these crowded streets, each intent on something for himself, and careless of what befalls the thousands he elbows aside. This might be very mysterious if it were only new. But selfishness is an old fellow, and, were it not for the prints of his knocks for some scores of years back, his green old age would be taken for just ripening manhood. A hale fellow, he; intimate, very intimate—a cheek-by-jowl companion—with not a few in this great Babel, with whom he goes about knocking right and left.

Nor is this moral frame of ours without its share of these mysterious demonstrations. Truth comes rapping and whispering gently at the door of the heart; and to the clamorous knockings of remorse, alas! few are strangers; they awaken us from our stupid reveries, or recall us from our thoughtless wanderings, and bid the sharp tones of conscience pierce our ears. We would fain, it may be, sleep on in false security; but knock succeeds knock, and wretched, oh! beyond expression, wretched they who yet bar the door and irremediably

sink into the chamber of moral death as the last faint sound of the messenger dies upon the ear. And I could tell of knockings yet more mysterious than even these—aye, more curious than all Rochester could manufacture; but I may not reveal these to all, or bruit them about to gratify that insatiable monster, the public.

Let me whisper them softly in your ear. There is such a thing as a maiden's heart. Curious little sanctum, *that!* containing things strange, passing strange. Of itself it is a little world, and yet this little world how capacious! What a living picture-gallery! what landscapes, and cottages, and castles, and palaces! what portraits hung up around its walls! and then what mighty hopes and fears! what imaginings! what longings! what anxious peerings into the future! what visions bright and radiant! what telescopic and microscopic wonders! and how this little sensory at times palpitates and beats and throbs! how it dilates as if to fill all space and again shrinks into nothingness! Think you *it* hears no knockings? Think you it never listens and fancies that it hears when all is still? Let its history for one short year be penned, and what a history of knockings would be there? Mysterious, aye, passing strange! How the little thing has fluttered like a frightened robin, and tried in vain to cease its flutterings, and hush itself into a quiet! Perhaps it would not that those knockings would actually cease, nor yet does it *consciously* wish their continuance. It sometimes endeavors to commune with itself; but, despite its every effort, some disturbing cause is ever present—some form constantly intruding. These mysterious knockings may perchance become more and more importunate; and it is certain, though it may be very mysterious, that the fastenings of the door of this little heart, (poor, tremulous thing!) too weak to resist, in some unguarded moment, or by some strange volition, sometimes yield, and in walks a strange tenant, henceforth to act the master in this little tenement, or, after a little tarrying, to be thrust out a no longer welcome guest.

I once *knew* such a little heart. It unfortunately heard the mysterious knockings. Curiosity (how strange for a *woman!*) awoke from its dozings. A most persevering knocker was this visitant. He came for “*yes*,” and “*no*” was no answer to him; early and late, rain or shine, it was knock, knock, at the door of that little heart. There was no use in turning a deaf ear, for deafness itself could not but hear such importunate rappings. Untiring perseverance deserves *success*. That little heart began to reproach itself for its discourtesy. Surely the door ought to be opened a little, a *very* little—to be left just ajar—a little look into the tenement might be allowed, and no harm felt; so it *was* left ajar; but still the intruder knocked on, peering in the while, and the knocks were so gentle, so full of melody—a strange, bewitching kind of melody, so full of entreaty—they spoke so imploringly—how could the door *shut* again? Softly it turned on its hinges, and the knocker was in that little tenement—a snug little home for the knocking knocker. The door closed, and the key was in his pocket, and his spirit danced to the tune of

Knock, knock away, knockers; in knocking's no sin,  
Nor is woman's heart steel, that knockings can't win.

PLATES FOR SEPTEMBER.—With our next No., through the kindness of Mr. D. Ford, of Toronto, we hope to be able to give our readers a variety of Canadian sleighs.

## Pen Illustrations of the Drafts.

### SOCIABLE WAGONETTE.

*Illustrated on Plate XIII.*

THIS very beautiful drawing, sent us by a valued correspondent, will furnish our readers with a desirable vehicle for six persons at a summer watering-place. The original was accompanied with the following note:

MR. EDITOR:—On Plate II. with your January Number is found a very neat style of Gig-wagonette, that suggested to my mind the thought that there might be a shifting top constructed in a very simple manner, with two long bows tipped with iron pins dropping into holes made in the corners of the seat rails, and secured by light stay-irons to the seat-back, as seen in the drawing. X. Z.

### PHAETON FOR FOUR PASSENGERS.

*Illustrated on Plate XIV.*

THE drawing for this design was kindly furnished us by Messrs Brewster & Baldwin, 786 Broadway. It makes a very light and pretty carriage for summer travel. The door, sham caned, gives a pleasing relief to the side view. Paint the body and carriage-part black. A very pretty mode of striping is to give a  $\frac{1}{8}$  of an inch red, bordered with two fine line stripes of white. The most fashionable mode is to line the body with blue cloth.

### BERLIN SPORTING WAGON.

*Illustrated on Plate XV.*

FOR this unique design we are indebted to our friend, Mr. Joseph Neuss, of Berlin, Prussia, coachmaker to the King, &c. In our estimation it will be appreciated by the American public, and add another valuable feature to our list of dog-carts, and sporting wagons. As may be observed, this wagon is constructed with panels of French imitations of basket-work, which our advertiser and friend, Mr. Chr. Volkert of 96 Walker Street, is ready to supply of various patterns. We would say to the public that these boards contain about 12 superficial feet each, and that when sending here not less than one board should be called for. The dogs in this wagon are stowed away under the front seat, and kept there by a wire-netting, as shown in the drawing.

### THE COAL-BOX BUGGY.

*Illustrated on Plate XVI.*

A NEW hand at the business, attached to this office, has produced the design we now offer to the public. That it is a beautiful one, none will dispute; its easy and graceful lines commends it to every builder of correct and refined taste. The article, "Fashions in Buggies," found on page 29, will supply the builder with all the requisite details he may need.

## Sparks from the Anvil.

### DEFECTS IN IRON.

RECENTLY at a meeting of the Manchester Philosophical Society, the vice-president exhibited a broken screw-bolt,  $1\frac{3}{8}$  inches square, that had been used to fasten a cart body to the axle. The break, which was near the head end, had very much the appearance of cast iron. At the point of fracture, an egg-shaped mass,  $\frac{1}{2}$  in. in diameter, was found imbedded, leaving a cavity as its mould in the metal on one side. He assumed that faults of this kind were probably owing to the rapid processes now adopted in reducing masses from the puddle into bars of wrought iron, while the metal was only partially converted to the malleable state, as appeared in this sample of bad iron. The iron, in a semi-fluid state, is passed from the furnace through a succession of rollers, without re-heating or fagoting, as was formerly done, and at once reduced to the sizes required. Mr. Dyer, the vice-president, seemed to entertain a poor opinion of the modern "improved rolling mills," and thinks that "the iron shuffled off in haste" is far inferior to that made fifty years ago, and that considering the many hazards to which life and property are exposed in our day, makes it important that all iron used in carriages and other machinery should be properly tested before use, and thus assure greater safety.

### HARDENING IRON AND STEEL.

A NEW process of hardening iron and steel has been invented by E. Partridge, of the Patent-axle works, Smithvie, England. This consists of first heating the article to be hardened in a bath of lead or other suitable molten metals, or in a retort, so as to be protected from the direct action of the fire. In applying to it, either in the bath or retort, or immediately on its withdrawal therefrom, a composition, presently to be described, either in powder or liquid, in some cases the article is returned to the bath or retort after such application. In preparing the composition he takes muriate of potash, or other substance containing cyanogen, or possessing like chemical properties, and reduces it to powder. He mixes with it powdered nitric and common salt, and sets fire to the composition. He takes the resulting ashes, or substance remaining after the firing, and powders it. This powder liquifies under heat, and he uses it alone, or mixed with charcoal (animal or vegetable), or other suitable form of carbon; or he liquifies the powder by dissolving it in liquid ammonia, or other suitable solvent, and applies it to the articles to be hardened in a liquid state.

### TO DISTINGUISH IRON FROM STEEL.

ONE of the best known methods of distinguishing steel from iron is by treatment with nitric acid. Nitric acid causes a black spot when dropped on steel, but not when dropped on iron. M. Saint Eclure, a French chemist, has noticed a still more reliable test, which is as follows: When an iron rod is immersed in nitric acid of ordinary strength, the acid boils about the surface of the iron; this action is continuous; but if steel be used instead of iron, this action of the acid only lasts for a few seconds, and then finally ceases. After the action of the acid has ceased, the steel is said to be in a "passive" condition,

and its capability of becoming thus "passive," discriminates it from iron.

## Paint Room.

### COMPOSITION OF PAINTS.

BY H. HARPER.

(Continued from page 42.)

Litharge as a dryer—All leads poisonous—Oils prepared with alkali destroys the brightness of vermilion—Caution against adulterated oils—Oxides, how formed—Greens generally poisonous; greater care should be taken in their use—A case of poisoning where doctors disagreed as to the cause; not an uncommon circumstance, however—A law to regulate druggists' prescriptions, but none to sell paints by; a defect somewhere.

LITHARGE is used as a dryer, either in boiled or raw oils, the same as with lead, or it makes a good body for other paints that possess the same color. All preparations of lead are more or less poisonous, and should be used in regard to their nature as such.

Vermilion is another red paint much admired for its beauty, and used when it can be placed in its appropriate place. It is an oxyd of mercury, and requires a dryer with it when used in raw oil. Americans have excelled all others in producing a cheap article of vermilion, but in quality both the Chinese and English excel them.

An important item about using vermilion has come under my observation, which it is important for painters to understand, if they do not already. In using it, it was discovered some two or three years ago, for the first time, that after the paint had been exposed to the action of the atmosphere for a few weeks it turned a dark brown. At first it was supposed to be the quality of the paint that produced this result, but it was afterwards found that some kinds of oil did *not* spoil the color. The boiled oil which was manufactured in Milwaukee, and sold to us almost as cheap as raw oil, would turn the paint to this brown color, while the raw oil would not have the same effect. This discovery brought about an inquiry into the process that they had for preparing oil, and it was found they did not follow the old way of boiling it, but made one barrel of "preparation" form a dryer for ten barrels of raw oil, without heating the same, and which they sold by the high-sounding name of "double boiled oil," at a price so low that the retailer could furnish it at only six cents on the gallon over raw oil. The price for which it was sold looked rather suspicious.

A remarkable coincidence about this cheap boiled oil turning vermilion to a brown color, is to be found in the record of patents on page 140, Volume Two of this Magazine. It is as follows: "Improved composition for mixing with paints. George W. Slogle (assignor to himself and O. A. Daily), of Washington, D. C.: I claim making Meloniline oil, or a substitute for linseed oil, by mixing together linseed oil, or other vegetable oil possessing similar qualities, water, and *sal soda*, or other similar suitable *alkali*, substantially in the manner set forth." The italics are ours. This alkali is the very article that would turn the oxyd of mercury black; and the process of boiling shellac in alkali, and then mixing it with oil, which has been known for years, would give the oil an appearance of boiled oil. The fact of this patent being

granted about the same time this "double boiled oil" (the name suggests the thought of "humbug") made its appearance, and that it has that peculiar effect on the oxyd of mercury, together with the cheap price for which it could be furnished, all go to establish the belief that we have patronized the "meloniline" oil business more than our interest demanded.

Before leaving the subject, let me caution painters and others about buying adulterated oil. This mode of deception is carried to such an extent that pure oil is a rare thing at the present time. Test the oil that you buy by the taste and smell, and if it is decidedly like that of flax seed, you can rely upon it as being good; and if it is only partially so, it is mixed with some other ingredient, and it will be a waste of work and paints to use it.

Venetian red, yellow ochre, French yellow, and other redish and orange colored paints that are taken from the earth, are oxides of iron mixed with clay. They are formed by the action of oxygen on the iron that is contained in the clay before it is taken from the ground. An inexhaustible supply of various tinges in color of this oxyd of iron has been found in Juneau Co., Wis., and will be found in all places where pure clay unites with iron. It would be far better if painters would use more of these kinds of paints than they are doing, for they are the most durable paints that we have. They do not possess as much body as lead, but about the same as zinc, and are more durable than either lead or zinc. They are not dryers of themselves, but are easily made to dry raw oil by adding about four ounces of sugar of lead and white vitriol, ground, equal parts in oil, to eight pounds of paint, or more if wanted to dry quicker.

Green paints are generally the result of mixing yellow with blue, but, as in the case of verdigris, they are made by the decomposition of a single metal sometimes. There are more extreme poisons found among the green paints than any other color. Chrome green is made by mixing Prussian blue with chrome yellow, and is perhaps the least poisonous of any belonging to that color, yet it is nearly as poison as lead. Paris green is composed of one-third arsenic and one-third copper,—two of the most virulent poisons that are to be found,—yet this poison is recklessly used by those unacquainted with its nature in almost every department. The confectioner uses it to ornament his most choice sugar toys; the tastefully decorated house is not considered complete without having the blinds covered with this gaudy paint. Its use is not more absurd in one case than the other. If the confectioner knew the nature of the decoration which he was applying to his sugar toys, he would be looked upon as a criminal of the most degraded stamp. The painter who uses Paris green for window blinds is not less stupid than the confectioner who poisons his candy, for he must know merely from the application of his paint that it is poison. The great mistake of the painter is that he makes no calculations for his paint coming off after once being put on. Again it is a paint recently introduced (comparatively speaking), and its composition is not generally known; has been, and probably will be used ignorantly by those who admire its beautiful color. The consequence is that the oil with which it is held so firmly on to the wood is consumed by the action of oxygen, and the poisonous paint is left free to be dusted off by wind or anything rubbing against it.

Many cases of poisoning in this way go undetected,

because the nature of such articles are not known and the cause is looked for in almost every place but the right one. A case to the point happened in the family of a painter. The painter was gone from home, and some four or five of the family became sick at the same time, and two different physicians were called, both of whom agreed that the sickness was the effects of poison. One of them commenced searching the premises for the cause. He soon discovered a copper kettle with which water was drawn from the well, and jumped at the conclusion that he had found the cause to be the oxyd of copper from the kettle, and published the same to be the case.

The other physician disagreed with him as to the cause, and said that the disagreeable taste and peculiar green look that the copper would give to water would be enough to keep sane people from being poisoned by it. He said "the cause of the poisoning was a mystery." Neither of these professional men thought of inquiring about the pounds of poison which the painter had in his house, the nature of which the family were entirely ignorant. We have a statute law in Wisconsin requiring druggists to record the date and names of all persons purchasing poison of them, and to label the article as poison. If an ounce of sugar of lead, white vitriol, or corrosive sublimate is bought of them, the person is booked carefully, according to law; but if pounds of white lead, Paris green, or verdigris is bought by a person entirely ignorant of its nature, it is not even labeled as poison. *Such* are the guards thrown around us for our safety by professional men and legislators.

(To be continued.)

#### WHERE TURPENTINE COMES FROM.

Among some other articles connected with painting, Spirits of Turpentine has advanced to almost fabulous prices, in consequence of the rebellious attitude the State in which it is largely produced has taken in our unnatural civil war. The advance from 45 cents per gallon to \$4.00, has given it an interest never before obtained, and set the ingenuity of the chemist at work to find some cheaper substitute for this very indispensable article—indispensable because thus far nothing has been discovered equally as well to fill its place. No reliance can be placed in benzoin for carriage painting, and no prudent man will think of using it.

Turpentine is the great staple of North Carolina, and it is now only obtainable by capturing the English blockade runners by our naval vessels, and the small shipments received from California. It is the produce of the *Pinus palustris*, or long-leaved pine, covering the sandy ridges formed between the water courses of the Southern States. These pines, standing closely together, sometimes shoot up into the air seventy or eighty feet, the branches interlacing each other, and almost shutting out the rays of the sun. At the foot of the tree the laborer commences operations by cutting deep notches into the trunk, a few inches from the ground, in the winter season. About three feet above this notch he removes the bark from the tree. From the surface thus scarified, about the first of March, the sap begins slowly to flow, increasing in quantity with the degree of heat that constitutes the summer season, and decreasing again with autumnal weather. The sap—turpentine—runs into these notches before mentioned, cut in such a way as to form a cup-

shaped receptacle, from which it is dipped out with a kind of wooden spoon, and put into barrels for market.

That which hardens on the scarified surface above the notch is scraped off and sold at a cheap rate for many useful purposes. The second year these same trees are scarified to the same extent *above* the first year's operation, and continued thus yearly, say for four years, when the sap ceases flowing. After this the same process is gone through with on the opposite side of the tree, until the tree, exhausted, fails to yield a remunerative product; is afterwards felled, cut into logs, made into a pile, something like that among us for obtaining charcoal, and, after being fired, produces the substance we call tar.

### Trimming Room.

#### ORNAMENTAL TRIMMING FOR A COUPÉ FRONT.

THE border near the molding is formed of edged lace, and made of brocatel, supplied with three tin boxes, and covered on the in and out sides with either morocco, cloth, or brocatel. The boxes are secured with strong packing box, ivory-headed nails. There are two window-lifters of wide lace, supported by straps, ornamented with tassels. A pocket and its flap, bordered with wide lace, ornaments the front, which has no seat. The remainder is

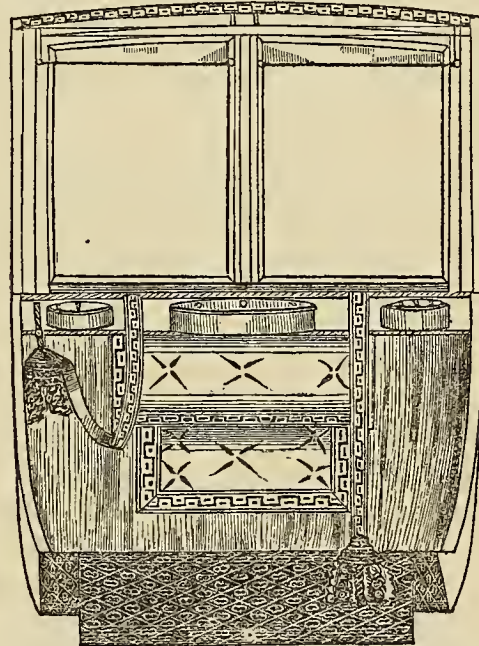

stuffed with hair; and between the two windows—the frames of which are covered with velvet—is a spring, the use of which is to keep them in place. Traveling bands are often doubled, that is to say, folded in two, so as not to be in the way of the windows. This is now the fashion of trimming the front of a plain coupé. The sides, the back, and the door, will be explained in a future number.—Translated for the *N. Y. Coach-maker's Magazine* from the *Mercuré Universel*.

#### CARE OF HARNESS.

AN article on this subject will be found on page 33 of our Fourth Volume. We find another in a late number of the *American Agriculturist*, contributed by a har-

ness-maker, slightly different: "Harness should be kept hung up on wooden pegs, in a clean, dry room, with a plank floor, so that it may be free from dampness. When soiled, it should be washed with Castile-soap suds. Harness that is in constant use needs oiling four times a year; if only occasionally brought out, as carriage harness, etc., twice a year will be sufficient, if the washing be not neglected.

"To oil harness, separate all the pieces, and lay them in water until thoroughly wet through, then wash them clean, and allow them to dry sufficiently. To know when they are in good condition for oiling, bend a strap, and if the water does not ooze out, it is dry enough. Train oil (whale oil) is sometimes used, but neat's-foot oil is much better. Mix with it a little lamp-black, and, with a brush, apply it to both sides of the straps. About six hours after oiling, wash the whole with Castile soap and warm water, let them dry, rub well with a woolen cloth, and buckle them together."

### Editor's Work-bench.

#### VISIT TO CANADA.

AN interval of nearly two years finds us once more on a visit to our fellow-craftsmen—this time extending into Canada. As we have previously given the public some account of the craft on the line of the New York Central Railroad, we shall condense our account of the present journey as far as possible, until we reach Niagara Falls and enter Canada.

Taking passage on the steamer Hendrick Hudson, on the evening of the 13th of May, daylight the next morning found us aground on the overslaugh twelve miles below Albany, detaining us some four hours. There is no telling how long we might have "stuck" there had not the "Uncle Ben" and another tug come to our aid, and, after repeated efforts, started us on our way, reaching our destination near meridian. Such delay as we experienced on this occasion tried our nervous temperament sorely. On the wharf we encountered a procession of city dignitaries and the 2d Regiment of New York volunteers, celebrating their return from a two-years' campaign against the rebels in Virginia. A cannon on the wharf directly in front of our landing was thundering forth a salute of honor, to the no small discomfiture of timid ladies and weak-nerved men. Making a hurried dispatch of business at Albany and Troy, we hastened on to Schenectady, when night overtook us. The next morning found us once more "on the rail." Stopping over at Fort Plain, we paid a visit to our old subscriber, Mr. Burke, finding him prosperous in business, but short of help. Indeed, this we found to be the general complaint all through this State, occasioned by the war fever—constitutional, apparently, with our young men. We heard of instances where men who were doing a very good and prosperous business, dropped all and donned the military garb for a

soldier's life in the camp. Alas! many of them will never return. May their virtues never be forgotten by their countrymen, and their noble example be imitated until rebellion is crushed out! Mr. F. Stichel, another carriage manufacturer at Fort Plain, gave us his patronage.

At St. Johnsville, further on, we found an enterprising firm, Messrs. Saltsman & Brother, where we were shown a very creditable specimen of work, and spent a profitable hour in conversation. Some idea of the profitability of keeping houses of refreshment on our railroad lines may be gathered from the fact that at this place we were told a former proprietor had retired rich, and his successor is in a fair way to become so.

At Little Falls we called upon our friend Mr. C. Benedict, a gentleman in every respect. After taking tea with him at his beautiful residence overlooking the place, he drove us through the village, showing us everything of interest, such as the paper and woolen mills, springs and reservoirs, and from different points beautiful views, such as no other locality presents. Mr. Benedict has one of the prettiest sites in all western New York for his villa, fitted out with gas and other modern conveniences. With an amiable companion and a competence, he is apparently the happiest of carriage-makers, which is saying much, for we do think, as a craft, its members often contrive to make themselves as miserable as possible. At Utica Mr. Bates still carries on the carriage business, but his former contemporaries have either failed or run away, rendering the trade, formerly extensive, now limitedly carried on. We made a call at Syracuse, on Mr. Hoyt, who is doing a good trade.

Our next visit was to Auburn, where we were met at the station by our esteemed friend S. Edwards Todd, Esq., with whose amiable family we tarried over the Sabbath. This visit we shall never forget. It marks a green spot in life's journey, pleasant to contemplate. In company with our host, we paid a visit to Fort Hill Cemetery, situated southward of the city, on the highest ground of which, in full view, stands an obelisk of hewn stone, to the memory of Logan, the last chief of a now extinct tribe, the Cayugas. It bears the following significant expression, in questionable English: "Who is there to mourn for Logan?" A sign-board tells the visitor that "The dead are here," and another cautions him to "Refrain from loud talking." As the body of the chieftain rests elsewhere, the first statement is undoubtedly false, and the last caution unnecessary, even when viewed in the light of superstition. On the brow of this hill formerly stood Fort Allegan, a section of the earthen walls of which are still visible.

On another day we were shown through the far-famed Auburn State Prison, in which at present about 750 convicts are confined. This is a smaller number than usual,—

no doubt caused by the war. To supply the requirements of labor in the different departments, many outsiders are daily employed, whose habiliments strangely contrast with those of the prisoners. It struck us as remarkable that men in a prison costume look larger and older than in citizen's dress. In this place all colors are on one common level, both black and white. We noticed that the "darkies" displayed considerable ingenuity in their work. The gentlemanly foreman of our friends Messrs. Hayden & Letchworth, the contractors, showed us the process of making hames on a large scale, and as it may have some interest for our readers, we are induced to present it somewhat in detail.

The wood (hickory or oak), sawed into proper lengths and split, is seasoned and bent, after being shaved on a cooper's horse. Without entering into all the details, we may state that the 6th process is dressing to pattern by ingenious machinery; 7th, planing; 8th, taking one corner off; 9th, placing the stay-irons on; 10th, boring; 11th, riveting; 12th, shaving or trimming off; 13th, adding the staples and top terrets: 14th riveting the terrets; 15th, placing hold-back rings of  $\frac{11}{32}$  iron in position, and cutting off ready for welding; 16th, riveting for neck buckles. Mr. Robbins has invented a very ingenious machine for making wrought cockeyes, in which about 75 pairs per day can be made. There is quite a difference between those known as the Concord and California hames. Of the former about 90 pairs per day are made, of the latter 125 pairs.

After visiting Rochester, and calling upon our friends there, finding business much improved since our last visit, we pushed on to Buffalo, the place at which La Rochefoucauld, a Frenchman, writing in 1795, states he could find neither "furniture, rum, candles, nor milk." As on former occasions, we obtained for the fifth time a club of subscribers in the shop of Messrs. Harvey & Wallace, for which we are placed under many obligations. Upon Washington Street we found an old acquaintance, D. C. Godwin, Esq., formerly of this city, who made us perfectly at home by his kind attentions. He has lately purchased a fine shop, and is doing a good business in the New York style of work. After making a call upon Messrs Pratt & Letchworth, who are extensive dealers in carriage materials, we left for Niagara Falls.

Here once more we viewed the falls from several points, with the deepest interest. They are certainly the most magnificent of all the wonders of creation, and no one can look on them without feeling an exalted reverence for the Creator. Here man taxes his ingenuity to turn a penny, sometimes ridiculously. Several fine views may be had from points along the river below. Some speculator has taken advantage of the circumstance that Blondin crossed the river on a tight rope a few years ago,

half a mile below the falls, and so has inclosed a space, inviting the visitor, by a placard, to "come see where Blondin crossed the river. Admittance 10 cents." At another turn in the river is a rude gate, over which we read: "To the Niagara Pleasure Grounds," and observed a brawny Milesian, whose demeanor seemed to say:

"Will you walk into my parlor," &c.,

trying to earn an honest penny. On crossing the suspension bridge, connecting our land with Canada, our eyes fell upon the following strange notice—strange to one who had scarcely seen a piece of silver in six months: "Notice.—Dec., 1862. On and after this date, silver will not be accepted by this company [the Great Western Railway] in payment for freight charges, or for tickets, in a larger proportion than five per cent of the total amount payable, and in no case must that amount exceed the sum of five dollars."

While Her Majesty's officials are examining our luggage, and upsetting things generally, let us take a survey of matters. The first thought that enters a Yankee's head, after entering Canada, is that he is in a foreign land, or, in other words, "out of the United States." Although a bridge only separates him from his dear native country, yet the surroundings convince him that he is under a monarchical government. Before his republican eyes sticks out V. [crown] R., the emblem of oppressions and persecutions in the past (the crown part, we mean) enough to make nature shudder. He may (as we did), while preferring his own kindred and people to any other, find some blind English subject of Victoria Regina reading to a gaping group from a copperhead Rochester newspaper long articles defaming our government and advocating traitorous resistance to the best form of rule ever devised. If an American is undecided as to how he should act about these days, let him take a tour abroad, and if he does not come back a good Union man, he will a contemptible renegade, on whom it would be too expensive to bestow a rope, and a trip to Dixie might possibly cleanse his leprosy.

Our ticket bore the impress on its face of "first-class," which led us to infer that we were now among two classes of people "over there." We suppose the two classes may be distinguished by the fullness of their pocket-books. With the thermometer up at 90° and custom-house officers peeping into every nook of the train, we are now on our way. The conductors, with brass buttons to their clothing and soldierly caps on their heads, show something bespeaking the importance of *their* situation. Directly the train stops at a station. An important personage (our neighbor called him a *flunkey*) now traces the entire length of the car, dressed "to kill," with a lackey at his heels, carrying an extra garment, to the no small amusement of such *uncultivated* minds as ours. We take

him to be a lord—at least, he must think himself such—and probably “thanks God that he is not like other men.” But perhaps *our* prejudices are leading us astray from the main subject—an attempt to give the reader a mind-daguerreotype of first impressions received abroad. We will here state that we afterwards found out that the native-born Canadians possess none of the characteristic objections we condemn, and that in every case we found them the warmest friends of the United States; it is only the foreign element that proves the exception, and that chiefly English and Scotch.

On our arrival at Hamilton, an entire stranger, we made our way to the factory of Messrs. H. G. Cooper and Co., and, telling our name, were soon made to feel ourselves among friends. This is the largest shop we saw in Canada, employing in former times ninety hands; at present, like most other shops in Canada, doing very little. We saw here, just completed, a fine phaeton, for Lieut. A. G. Russell, of the Prince's Own Rifle Brigade. As elsewhere, so here, we saw “any quantity” of British soldiers, which, since the Trent affair, have been quartered in the provinces, to frighten the Yankes—perhaps. Through the kindness of Mr. Cooper, in a long ride, we were shown the principal objects worthy of note in Hamilton. We hope to see him again in our travels. May he live long to adorn our profession! We also, at another shop in the city, came across a friend from New York city, Mr. D. McGregor, whose kind attentions in promoting the interests of this *Magazine* shall never be forgotten.

(To be continued.)

#### HALF-CENTENNIAL ANNIVERSARY IN A COACH FACTORY.

OUR friend, James Goold, Esq., of Albany, established a coach factory in that city, April 20, 1813. In commemoration of the circumstance that fifty years had expired since, still finding him in business, on the 20th of April last, the employees of his firm, sixty-six in number, went in a body to his residence, and presented him with a service of silver, consisting of an ice pitcher, salver and goblets, and an engrossed and framed copy of the following resolutions, passed four days previously at a meeting held in the factory building:

WHEREAS, The Albany Coach Factory, established in 1813, by Mr. James Goold, its present senior proprietor, has nearly completed its 50th year, it is, therefore,

*Resolved*, That the undersigned, at present employed in the Albany Coach Factory, deem it eminently proper that they should offer their congratulations to Mr. Goold on this occasion, and express to him those sentiments of respect and esteem in which they are so unanimously agreed.

*Resolved*, That in establishing this business, and conducting its growth to its present size and prosperity, through the manifold difficulties arising from political and financial fluctuations (which are the common experience of all business men), and also through the more trying, because sudden and overwhelming, calamity of fire, Mr. Goold has created a testimonial, more expressive than words, of

the value of those principles of strict integrity and persevering industry, which have always marked his business career.

*Resolved*, That while we admire and desire to imitate so noble an example, we will not be unmindful of our duty to our beloved country under whose liberal and beneficent Government we may feel assured that success and prosperity will attend *Industry* and *Integrity*.

*Resolved*, That with our congratulations on this occasion, we offer to Mr. Goold the accompanying gift, and ask his acceptance of it as a slight testimonial of the sincerity of the sentiments expressed in the foregoing resolutions.

*Resolved*, That in causing the name of Mrs. Goold to be inscribed on one of the pieces, we have desired to express our appreciation of the active and ready sympathy, so invaluable in her own family, but not circumscribed by ties of kindred or limited by anything but the demands for its exercise.

*Resolved*, That Monday, 20th April, being the Anniversary of the commencement of Mr. Goold's business course, we will assemble in this place at 8 o'clock P. M., and proceed in a body to call on him at his residence, and present these resolutions and the gift we have prepared.

As every preparation had been made, unknown to the venerable gentleman, he was taken by surprise, and, on the resolutions above given being read to him, his emotions fairly overcame all attempts at a suitable reply. Two days after this Mr. Goold sent to the committee the following written address:

To Messrs. B. S. Spencer, Geo. Benham, W. H. Perry, W. Deming, W. Dornet, H. O. Lemily, D. McCan, and O. B. Fuller, Committee, &c.

MY FRIENDS:—My surprise and gratification were both so great on receiving your kind expression of regard for myself and family, on Monday evening, that my emotions were at the moment too deep to find ready utterance.

As the few words spoken on that occasion were so imperfect an expression of my feelings, I take this method of assuring you of my grateful appreciation of such a demonstration.

For your beautiful and highly valued gift, with the inscription commemorative of the lapse of half a century spent by me in active business life in this city; for your resolutions, so beautifully expressed; and for your kind visit and hearty congratulations,—you will accept my warmest thanks. When I stood before you on Monday evening, I am free to confess that, mingled with other feelings, was something of pride in your appearance, and a consciousness that a compliment from such a body of men is one that any employer may be proud to receive.

I saw before me one who, having grown gray in my service, is still one of your number; others (present by your invitation) who, having been apprentices and inmates of my house many years since, now occupy honorable positions in society; many of your own number who have been for a long time in my service; and still another class, who are but now learning the business; and was deeply moved by the thought that all were united in this testimonial, thus furnishing, as it were, living witnesses to my fifty years of business life.

If in this half century I have fulfilled my mission as a member of society; if I have, by example or precept, helped to form the character of any of the large number of young men entrusted to my care; if I have made or perfected improvements in my special branch of manufactures; if I have aided to elevate the character of the mechanic,—the retrospect will bring no regret.

It falls to the lot of few to review so long a period of



active service in one branch of business. In the hasty retrospect suggested by your presence and the resolutions on Monday evening, among the varied events which passed in rapid succession before my mind the most prominent was the fearful calamity which marked the expiration of the first twenty-five years of my business life. You will, of course, understand that I allude to the destruction of my property by fire, in May, 1838. The actual importance of this event would give it prominence in my thoughts; but the sight of your communication, with such an array of signatures, called vividly to mind the circumstances which immediately followed that conflagration.

On the 29th of May, 1838, I received a communication equally surprising and gratifying with your own, and with about an equal number of signatures, but of an entirely different character,—it being an expression of the kindest sympathy, and a most liberal offer of assistance, signed by a large number of our best citizens. So prompt was the action that, while the smoke was yet rising from the ruins of my factory, I was the recipient of a loan, without interest for five years, sufficient to enable me to erect the commodious building we now occupy, and maintain my position among the business men of the city. The feelings of gratitude which I have always cherished toward the gentlemen who thus honored me were reawakened at this time by the thought that, but for their generous aid so promptly bestowed in my time of trouble, I might not have been able to enjoy the pleasant celebration of this anniversary.

Many of them have passed away; some of them leaving sons who are filling their places honorably. Of the survivors, one of our most venerable citizens (Hon. Gideon Hawley) is the author of the paper to which I have alluded; another is one of our pre-eminently prominent citizens (Hon. Erastus Corning), distinguished alike for his public spirit and liberality.

Some of them stand high in the different professions, while others represent different branches of trade or mechanics. May they be long spared to continue their course of usefulness and honor in our community!

I have ever striven to conduct my affairs in such a manner that they should feel satisfied that their generous and substantial assistance had not been misplaced.

If I have succeeded in this, and in winning the respect of those with whom I am daily associated in the way of business, I have achieved an object dearer to me than the accumulation of wealth.

With my best wishes for your health and prosperity, I remain truly your friend,

JAMES GOOLD.

ALBANY, 22d April, 1863.

One gentleman of the company had been in Mr. Goold's employ forty-nine years and six months. To the honor of the craft be it noticed, every one of the sixty-six signatures to the resolutions were individually written in full, in a fair hand. We doubt if so many in one shop could be found in Europe to write their own names. Having been suitably entertained by the "Old Boss," the men departed, led by a band of music, to the sound of which they marched to the residence of the junior partner, Mr. Bush, whom they serenaded, and after returning

to the shop, quietly dispersed to their several homes. This firm have always shown themselves friends by regularly taking our Magazine. Among those still employed in the factory we notice, as old subscribers, the chairman of the meeting, Messrs. B. S. Spencer, Wm. H. Perry, Jas. H. Thrall, F. C. Moll, A. G. Ragg, and F. D. Kennedy.

#### HOW THE REVENUE TAX AFFECTS CARRIAGE-MAKING.

AGAINST either the wisdom or folly of taxing acknowledged luxuries for the purpose of raising the means with which to suppress and put down the unnatural rebellion against our popular government, we have nothing to say in this place; but when an ignorant and inconsiderate committee burthens so respectable and useful an occupation as ours manifestly is with taxes "too grievous to be borne," we think that we have great reason for complaining, and ought not to be censured for "grumbling" a little. Perhaps there may be a few shops in the Union where the tax will operate as manifestly beneficial, because the great popularity of their work will enable them to sell *their* carriages at any price they may choose to demand, and thus more than cover the extra costs of the tax; but by far the greater number are of the class where customers will never submit to the additional expense the tax entails, and consequently these in time must be ruined or cease manufacturing altogether, unless some legislative act provides a speedy remedy. We have no doubt that many who would under other circumstances purchase, will now go without rather than pay the higher price for a carriage and horse-keeping. This will lessen the sale, and greatly injure our interests.

This is not the first time that carriages have been made to pay for national indiscretions. At the end of the last century, on coming out of her American and continental wars, England imposed duties at once onerous and inimical to the coach-making business in various ways. It is true these duties were paid only by the richer classes, or those able to keep a carriage, but they were felt throughout the nation. The coach-builder *felt* it as he paid 20s. for every four-wheeled, and 10s. for every two-wheeled, pleasure vehicle. Every purchaser *felt* it when he was called upon to pay an annual tax of 8l. 10s. on his "four-wheeled;" for a second one, 9l. 18s.; and if *sportive* enough to have a third carriage, 12l. Felton assures us that this tax was so detrimental to the coach-building interests that more than half the members belonging to the different branches were obliged to engage in some other business to obtain a livelihood. For twenty-five years this difficulty continued, and the annihilation of the craft was only prevented by a greatly modified system of taxation.

The more general and larger demand among us, and

the characteristic enterprise of our people, may overcome some of the evils which the craft in England complained of sixty years ago; but one cannot help feeling, as he pays a tax on the full value of every carriage he sells, where the materials used—more than one half of them—have already cost him the 3 per cent tax when purchasing from the manufacturer or dealer, that his prospective profits will be very small. Let us see how the tax affects us. We will take a buggy for examination. We find that we are

## TAXED.

On Wheels purchased ready-made, 3 per cent on	\$16 00
“ Axles, \$8; Springs (34 lbs.), \$7.82.....	15 82
“ Iron for balance-bolts, shaft-couplings, &c....	12 00
“ Cloth, 1½ yds. body, \$4.38; 4½ yds. head- lining, \$13.50.....	17 88
“ Silk fringes.....	4 00
“ Oil-cloth.....	0 60
“ Enameled cloth apron.....	2 25
“ Carpet.....	2 75
“ Props, shaft-tips, and slat-irons.....	2 00
“ Plating desk, capping nuts, and hub bands...	3 50
“ 80 ft. of Enameled cloth (taxed 5 a 7 mills per foot).....	20 00
“ Paint varnishes and several small articles not enumerated above, say.....	6 00
	\$102 80

The following we shall suppose is

## NOT TAXED.

The Body-work and material.....	\$12 00
“ Carriage-part.....	8 00
“ Smith work.....	18 00
“ Trimmer's wages.....	16 00
“ Painting.....	16 00
“ Incidental labor.....	15 00
	\$85 00

It will thus be seen that we are taxed on over 50 per cent of the material used, so that, when made into a carriage and sold, we pay about 5 per cent tax. We shall await the results of this taxation on our productions with much interest.

## EDITORIAL CHIPS AND SHAVINGS.

VALUE OF THE COACH-MAKER'S MAGAZINE TO THE CRAFT.—In our recent visit among the craft we found the most prosperous shops were such as appreciated our Magazine, and were receiving its regular issues. Where it is not taken we found an antiquated style of work, and almost invariably some old “fossil” the proprietor, grumblingly declaring the carriage-making business to be the meanest occupation a white man can be engaged in. A similar fact has received the attention of a Western correspondent. He says: “I can make a sure guess, as soon as I see the inside of a shop, what can be done, and that those who do subscribe are deserving of and do get the public patronage.” The truth is, the man who looks at a four-dollar bill twice in making up his mind about subscribing to a work specially devoted to the interests of his trade, is too *slow a coach* for this progressive age.

To argue with such *intellects* would be “casting pearls before swine.”

NUMBER OF VEHICLES IN NEW YORK.—There are at present about 13,500 vehicles of all descriptions in this city, viz.: 5,000 private carriages and wagons; 558 omnibuses; 945 hackney coaches; 255 express wagons; 416 charcoal and wood wagons; 278 junk carts; 5,374 public carts; 724 dirt carts.

HARPER'S AXLE GAUGE.—Have our readers noticed our friend Harper's advertisement, on the third page of our cover, of a Gauge and Scale for gauging the underside of axles? As it deserves, we understand that it is receiving, the attention of scientific carriage-makers, and meeting with encouraging sales. One can be seen at this office, which our friends are invited to inspect.

SHABBINESS OF VICTORIA'S EQUIPAGES.—A disgusted Englishman lately wrote to the *London Times*, to say that Victoria's carriages, as displayed in the recent royal processions, were a disgrace to the British nation. The horses were unmatched, and the harness and liveries old and shabby, and the whole turnout generally unfit for a “moderately fastidious woman of the Royal Bed-chamber.” He lays the chief blame in this *serious* matter upon the Master of the Horse, and thinks if that personage would do his duty decently, or with the attention he gives to drawing his salary, the Queen might at least travel respectably, if not elegantly. We suggest that our *Dormant* cotemporary attend to this matter, and see that the Queen is “fixed-up,” and not let the “nation” suffer disgrace any longer.

GENUINE DOG-CARTS.—If our readers would see “a real, genuine, original” dog-cart, they only need station themselves for an hour on some of the avenues of this city about 11 A. M. To see the labor some lazy Dutch “bone-gatherer” exacts from his canine family, in propelling his cart, is enough to make a feeling man's heart ache and some of our city curs blush. Perhaps, however, this is as good a use as they can be put to. We understand this is the use dogs are put to in Germany, and that it is not an unusual thing to see a little cart drawn by a woman and a dog, on their rounds distributing milk, in the Prussian capital itself.

## LITERARY NOTICES.

No publication affords us better entertainment than the Historical. One gathers from such, “food for thought” never found in novels. Of this kind is the *New England Historical and Genealogical Register, and Antiquarian Journal*, published quarterly by Joel Munsell, of Albany, N. Y., at \$2 per annum. It is illustrated with steel portraits, and contains brief biographical sketches of celebrated personages, family pedigrees, and early American history to be found nowhere else, and ought to be in the hands of every native-born New-Englander throughout the world. They will find this a valuable addition to the library, and once obtained, an indispensable book of reference of nearly 400 pages, 8vo.

Whether some literary thief in the post-office has abstracted our *Atlantic Monthly* for the last two months, or not, we cannot say; but one thing we know, that whereas for four years we have got it regularly, the two past months *we didn't*. This inclines us to think our favorite is getting to be *somebody else's favorite*. We advise our friend to subscribe, for our postmaster has promised to

use diligence hereafter, and see that our box is no longer robbed; so look out! The May number is running over with good things. Among the articles is one entitled "The Human Wheel, its Spokes and Felloes," which every carriage-maker ought to study in connection with our teachings. It will wonderfully enlarge his knowledge of *wheel-making*. The author should be elected an "honorable member" of the craft forthwith. There are other articles both in the May and June numbers calculated to please as well as instruct all classes. The Atlantic differs from most works in this—the more you read, the better you will like it. Try it and see.

#### FOREIGN IMPROVEMENTS IN CARRIAGES.

**WHEELS.**—June 24, 1862, G. Gray, of Greenwich, Eng., proposed that a metal nave be used in preference. Each nave is cast in two parts, in one of which the mortices, or sockets, for the inner end of the spokes are formed; and such mortices are made, by preference, with parallel sides, the mortices radiating from the centre of the nave. It is preferred that the angular parts of the nave which come between the spokes should be cast hollow in order to obtain lightness. The second or outside part of the casting simply consists of an outside cover to the nave, fixed on it by screws, the ends screwing into an interposed disc or flat ring of wrought iron, and this ring is fixed to the first part of the casting by bolts and nuts, the heads of the bolts being countersunk in the disc or ring, and passing through holes through the angular parts of the casting which come between the spokes. In putting a wheel together the wrought-iron disc is put in its place, so that it does not come in contact with the casting, but is held by movable pieces a short distance away from it; the bolts are then passed through the ring and casting, the nuts screwed up, and the ends of the wood spokes driven into their places, the tenons being slightly taper. The flat ring or disc does not fit around the cylindrical central part of the casting of the nave, against which the inner ends of the spokes come when they are driven home, and the fact of their being driven home will at once be seen through openings in the center of the ring or disc. The spokes having been driven in their places, the outer plate is put in its place and fixed by screws to the wrought-iron disc; should the inner ends of the spokes shrink, the disc may be tightened by the nuts.

**IMPROVED CARRIAGE.**—C. Wessely, of Lambeth-road, Surrey, Eng., 7th of July, 1862, applied for a patent in which the load and weight of the body of the carriage should rest wholly or chiefly upon the hub of the wheel, without bearing upon the axletree—cranked axletrees. This is effected by means of anti-friction wheels bearing upon the hubs of the above-mentioned wheels, and turning concentric around steel trunnions. These steel trunnions are fixed in the upper part of a vertical piece of flat iron, whose lower end encompasses, by means of clutches, the vertical parts of the crank axletree in such a way as to allow an up and down sliding of the former. Unto these pieces of flat iron the body of the carriage is attached, either by means of springs or directly. A knuckle is formed on the piece of flat iron just above the highest point of the axletree, so as to form a rest for the whole load upon the axletree in case the trunnion of the anti-friction wheels should give way, and thus may move on like common vehicles.

**APPARATUS FOR ASCERTAINING THE FARES AND EARNINGS OF PUBLIC VEHICLES.**—Aug. 14, 1862. The inventor, W. J. Curtis, of Holloway, England, in adapting his apparatus to a cab or omnibus, provides a packet of cards, having on their face a graduated dial, numbered and representing distances in miles, half miles, and quarter miles, if necessary. Each passenger will receive one of these cards on entering a vehicle, it having been pierced by a punch to indicate a starting point on the disc. On leaving the vehicle, the card is to be again pierced, and the distance between the two nicks will show the distance traveled. The punch will, however, when making the second nick, which indicates the termination of the passenger's journey, strike out a portion of the card and discharge it into a receiver, which is accessible only to the proprietor of the vehicle. This punched out portion will have a counterpart of the nicks retained by the passenger, and will, therefore, show the amount of the fare chargeable to the passenger. Abandoned.

**TWO-WHEELED CARRIAGES TRANSFORMED TO FOUR.**—Application was made, on the 14th of Aug., 1863, by J. Cook, of Fitzroy Place, Kentish Town, London, whereby he constructs two-wheeled carriages so as to admit of their being coupled longitudinally, and employed together as four-wheeled carriages, space being left between the couplings of the fore and hind wheels for the object of the lock or turning, whereby wheels of a large and uniform size may be used throughout in connection with cranked or plain axles, and the said carriages coupled either singly or in sets.

**SPRINGS APPLICABLE TO WHEELS.**—Wm. M. Mayer, of Hoxton, Middlesex, Eng., proposes to insert in the naves of wheels, or in a box or casing surrounding the axle or nave, a spiral spring or springs, so as to prevent all shock or jar to the axle during the running of the wheels.

**COMBINED CART AND SLEIGH.**—28 July, 1862. E. Burnett, of Ashford, Kent, has invented and patented a vehicle forming a combined cart and sleigh. The shafts are jointed by a hinge to the cart or sleigh, and, at a short distance from the joint, underneath each shaft, a curved branch or arm of iron descends, forming a connecting stay, which is attached to a flat spring extending across the under part of the boot, to which it is attached by bolts, screws, or other fastenings. The curved arms are hinged at a short distance from their attachment to the shafts, in order to allow the shaft points to descend to the ground when the cart is not in use, and also to prevent fracture or other damage to the shafts or cart in the event of the horse falling. This arrangement also relieves the shafts of much weight and strain. The springs are formed of elliptical bars or plates, and only consist of four plates, presenting the appearance of a small spring inside a large one, with which it is connected at the upper and lower bearing surfaces of the cart and axle. The seats are made to hold four persons, who sit back to back; the front seat is adjustable, and can be shifted backwards when only two persons are to ride, so as to cause the cart to balance as when four persons are riding. When the wheels are removed, as well as the iron feet, on which the cart falls forward and bears on the ground, when not in use, the body can be attached to a sleigh-frame, and be used in winter as a sleigh, with all the advantages of the spring shafts before described.

## CURRENT PRICES FOR CARRIAGE MATERIALS.

NEW YORK, June 14th, 1863.

Apron hooks and rings, per gross, \$1.25.  
 Axle-clips, according to length, per dozen, 50c., 63c., and 75c.  
 Axles, plain taper, from  $\frac{1}{4}$  to 1 in., \$5;  $1\frac{1}{2}$  in., \$6;  $1\frac{3}{4}$  in., \$6.50.  
 Swelled taper, 1 in. and under, \$5.25;  $1\frac{1}{2}$  in., \$5.75;  $1\frac{3}{4}$  in., \$6.75;  $1\frac{1}{2}$  in., \$8.50;  $1\frac{3}{4}$  in., \$10.  
 These are a superior axle, and more frequently called for than any others.  
 Do. case-hardened, half-patent, \$7; do. \$8; do. \$8.50.  
 Bands, plated rim, under 3 in., \$1.75; over 3 in., \$2.  
 Do. Mail patent, \$2.50 a \$3.25.  
 Do. galvanized,  $3\frac{1}{2}$  in. and under, \$1; larger, \$1 a \$2.  
 Basket wood imitations, per foot, 88c.  
 When sent by express, \$2 for a lining board to a panel of 12 ft.  
 Bent poles, each \$1.  
 Do. rims, under  $1\frac{1}{2}$  in., \$2 per set; extra hickory, \$2.50.  
 Do. seat rails, 44c. each, or \$4 50 per doz.  
 Do. shafts, per pair, 75c.; bundles, \$4.50; extra, \$5.50.  
 Bows, per set, light, 75c.; heavy, \$1.12.  
 Bolts, Philadelphia, per gross, as per printed list.  
 Do. T, per 100, \$3 a \$3.50.  
 Do. tire, \$1.05 a \$1.80, according to size.  
 Buckram, per yard, 25c. a 35c.  
 Buckles, per gross, 88c. a \$1.25.  
 Burlap, per yard, 25c.  
 Buttons, japanned, per paper, 15c.; per gross, \$1.50.  
 Carriage-parts, buggy, carved, \$4.  
 Carpets, Brussels, per yard, \$2; velvet, \$2.75; oil-cloth, 60c. a 80c.  
 Castings, malleable iron, per lb, 12c.  
 Clip-kiugbolts, each, 30c.  
 Cloths, body, \$3.75 a \$4.50; lining, \$2.25 a \$3.25. (See *Enameled.*)  
 A Union cloth, made expressly for carriages, and warranted not to fade, can be furnished for \$2 a \$2.25 per yard.  
 Cord, scaming, per lb, 25c.; netting, per yard, 5c.  
 Cotelines, per yard, \$3.50 a \$5.  
 Curtain frames, per dozen, \$1 a \$1.50.  
 Do. rollers, each, 75c. a \$1.  
 Dashes, buggy, \$1.75.  
 Door-handles, stiff, 50c. a 63c.; coach drop, per pair, \$2 a \$3.50.  
 Drugget, felt, \$1.62.  
 Enameled cloth, 5 qrs., 65c.; 50 in., \$1.50.  
 Enameled linen duck, 4 qrs., 60c.; 5 qrs., 80c.; 52 in., 90c. Colored, 15c. higher per yard.  
 Felloe plates, wrought, per lb, all sizes, 15c.  
 Fifth-wheels wrought, \$1.25 a \$1.38.  
 Fringes, festoon, per piece, \$1.75; narrow, per yard, 15c.  
 For a buggy top two pieces are required, and sometimes three.  
 Do. silk bullion, per yard, 35c. a 75c.  
 Do. worsted bullion, 4 in. deep, 35c.  
 Do. worsted carpet, per yard, 6c. a 10c.  
 Frogs, 38c. per pair, or \$1.63 per dozen.  
 Glue, per lb, 25c.  
 Hair, picked, per lb, 50c.  
 Hub-borers (Dole's) for light work, \$15; heavy, \$18 a \$20.  
 Hubs, light, morticed, \$1; unmorticed, 75c.—coach, morticed, \$1.50  
 Japan, per gallon, \$4.50.  
 Knobs, English, \$1.75 a \$2.  
 Laces, broad, silk, per yard, 70c.; narrow,  $5\frac{1}{2}$ c.; silk, 8c. a 10c.  
 Do. broad, worsted, per yard, 31c. a  $37\frac{1}{2}$ c.  
 Lamps, coach, \$14 a 18.  
 Lazy-backs, \$9 per doz.  
 Leather, collar, dash, 25c.; slit do., 15c.; enameled top, 25c.; harness, per lb, 45c.; flap, per foot, 15c. a 20c.  
 Linen, heavy, a new article for roofs of coaches, 55c. a 70c. per yard.  
 Moquet,  $1\frac{1}{2}$  yards wide, per yard, \$5.  
 Moss, per bale, 10c.  
 Mouldings, plated, per foot, 12c. a 15c.; lead, door, per piece, 30c.  
 Muslins, per yard, 20c. a 35c.  
 Nails, lining, silver, per paper, 6c.; ivory, per gross, 25c.  
 Name-plates.  
 See advertisement under this head on 3d page of cover.  
 Oils, boiled, per gallon, \$1.50.  
 Paints. We quote white lead, extra, \$3.50; Eng. pat. black, 25c.  
 Pekin cloth, per yard, \$2.  
 A very good article for inside coach linings.  
 Plushes, per yard, \$2.  
 Pole-crabs, silver, \$5 a \$6; tips, \$1.12.

Rubbing stone, per lb, 12c.  
 Sand paper, per ream, \$3.50.  
 Screws, gimlet.

Add to manufacturer's printed lists 20 per ct.

Do. ivory headed, per dozen, 38c. per gross, \$4.  
 Serims (for canvassing), 15c.  
 Seats, buggy, pieced rail, \$1.75; solid rails, \$2.50.  
 Shaft-jacks (M. S. & S.'s), light, \$2.60; heavy, \$2.87. a \$3.25.  
 Do. tips, extra plated, per pair, 31c.  
 Silk, curtain, per yard, \$1 a \$2.25.  
 Slat-irons, wrought, per pair, 55c.  
 Slides, ivory, white and black, per doz., \$6; bone, per doz., \$1.50;  
 No. 18, \$1.75 per doz.  
 Speaking tubes, each, \$4 50.  
 Spindles, seat, per 100, \$1.  
 Spring-bars, carved, per pair, \$1.  
 Springs, best temp. Swedes, per lb, 24c.; black, 17c.; bright, 18c.;  
 best tempered, 21c.  
 Two springs for a buggy welgh about 25 lbs. If both 4 plate, 34 to 40 lbs.  
 Spokes, buggy, per set, \$3, or about 5c. each for all under  $1\frac{1}{2}$  in.  
 For extra hickory the charges are  $6\frac{1}{2}$ c. each.  
 Steel, Farist & Co.'s Homogeneous American, per lb, 16c.  
 Do. English Homogeneous, do. 20c.  
 Do. Compound tire, do. 7c.  
 Stump-joints, per dozen, \$1.25 a \$1.50.  
 Tacks, 5c. and upwards per paper.  
 Tassels, holder, per pair, 63c. a \$1; inside, per dozen, \$3; acorn trigger, per dozen, \$1.25 a \$1.50.  
 Terry, per yard, \$7.  
 Top-props, Thos. pat., per set, 35c.; plain, com., 35c.  
 The patent props, with silver-plated nuts, per set, 67c.

Tufts, ball, per gross, 50c.; common worsted, 12c. a 25c.  
 Thread, Marshall & Co.'s Machine, No. 432, \$2.40 per half lb; No. 532, \$2.75 do.; No. 632, \$3.50 do.  
 Turpentine, per gallon, \$4.  
 Twine, tufting, per ball, 35c.  
 Varnishes (Amer.), crown coach-body, \$5 a \$5.50; hard drying, \$5; nonpareil, \$5.50.  
 Do. English, \$9 a \$9.58; or \$6.25 in gold, or equivalent.  
 Do. American imitation of English, \$7.  
 Webbing, per piece, 44c.  
 Whiffle-trees, coach, turned, each, 25c.; per dozen, \$2.50.  
 Whiffle-tree spring hooks, \$2 per doz.  
 Whip-sockets, rubber, per dozen, \$7 a \$9; pat. leather, stitched, \$3.  
 Yokes, pole, each, 75c. to \$1.25.  
 Yoke-tips, 50c. a 75c.

We intend to enlarge and correct this list monthly, so as to enable those who commission us to make their purchases to ascertain by computation about the amount they require to remit us. This should be done, if a large sum, by draft to our order in New York, or if small, in a registered letter to our address. None but cash orders filled, and where C. O. D. bills are forwarded with the goods by express, charges for collection must be added, which amount in ordinary cases to from 25c. to \$1, according to distances. All this may be saved by sending us the money with the order. Please read notice of "General Business Agency," on 3d page of the cover, in connection with the above.

## TO READERS AND CORRESPONDENTS.

BACK VOLUMES of this work will be sold, in numbers, for \$3; when bound, for \$3.50, to which, if sent by mail, 48 cents must be added to prepay postage; if two or more volumes are called for at one time, they can be had for \$3 each, or will be sent by express, at the purchasers' expense, at the same price. The subscription to the Fifth Volume, now in course of publication, will be (in consequence of the advance in paper and printing) four dollars, IN ADVANCE, for the twelve numbers; and these will be issued, in 1863 for Jan., March, May, July, Sept., Nov., Dec., and afterwards monthly until the close of the volume in May, 1864.

AGENCY.—Our friend Mr. Henry Harper, who is traveling in the West, is authorized to take subscriptions for us, and receipt for moneys paid; and any contract he enters into concerning this Magazine will be honorably carried out by the Publisher. In Canada West, Mr. Robert McKinley, at St. Catharines (dealer in carriage-hardware), will act as our local agent.



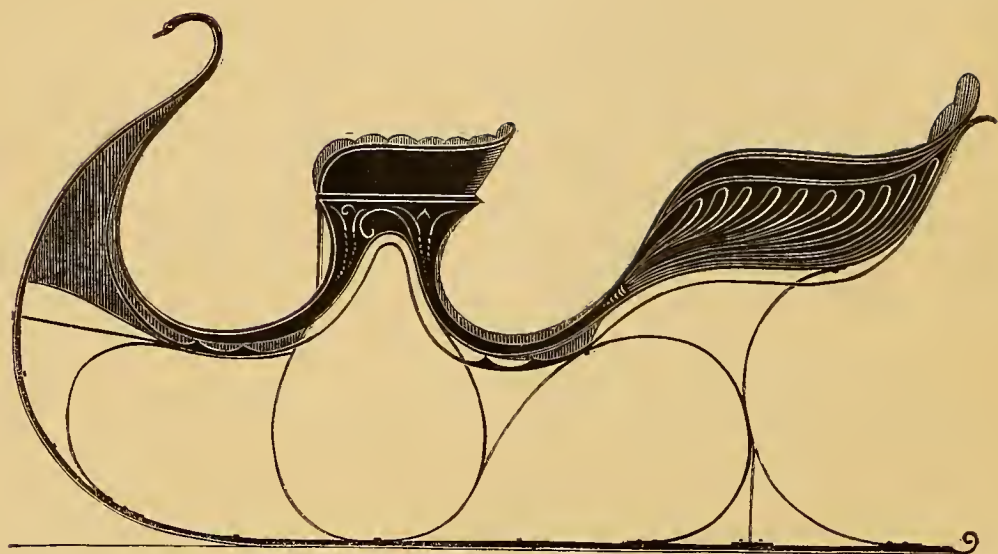

CANADIAN FAMILY SLEIGH.— $\frac{1}{2}$  IN. SCALE.

*Engraved expressly for the New York Coach-maker's Magazine.*

*Explained on page 73.*

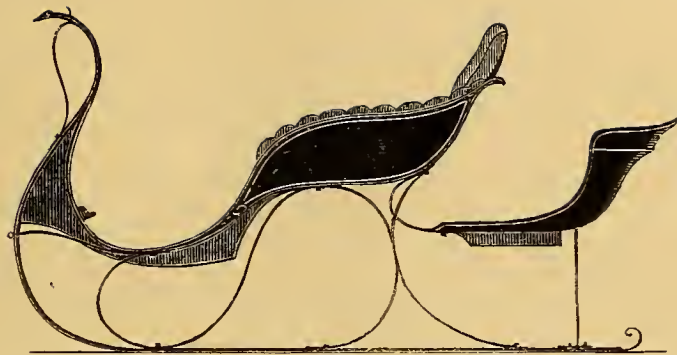

PHAETON SLEIGH.—SCALE UNCERTAIN.

*Engraved expressly for the New York Coach-maker's Magazine.*

*Explained on page 73.*

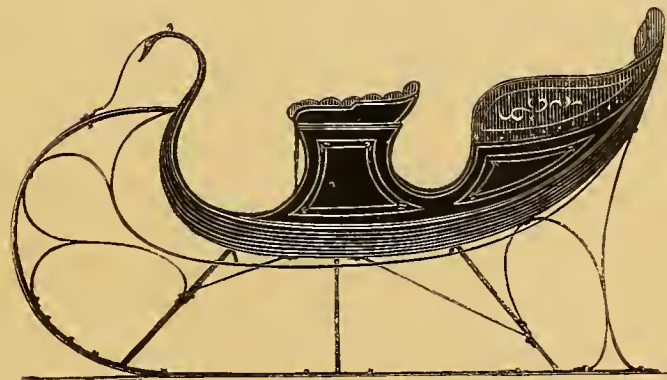

FOUR-SEATED COUNTRY SLEIGH.—SCALE UNCERTAIN.

*Engraved expressly for the New York Coach-maker's Magazine.*

*Explained on page 73.*







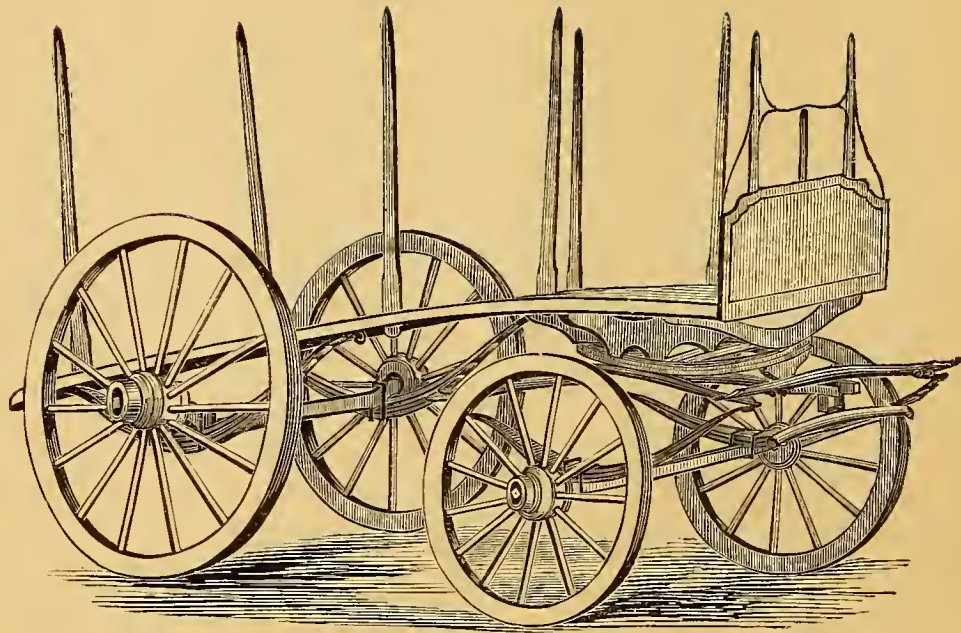

TRUCK WAGON FOR CITY USE.—SCALE UNCERTAIN.

*From Messrs. O. Kipp & Son, New York.*

*Explained on page 73.*

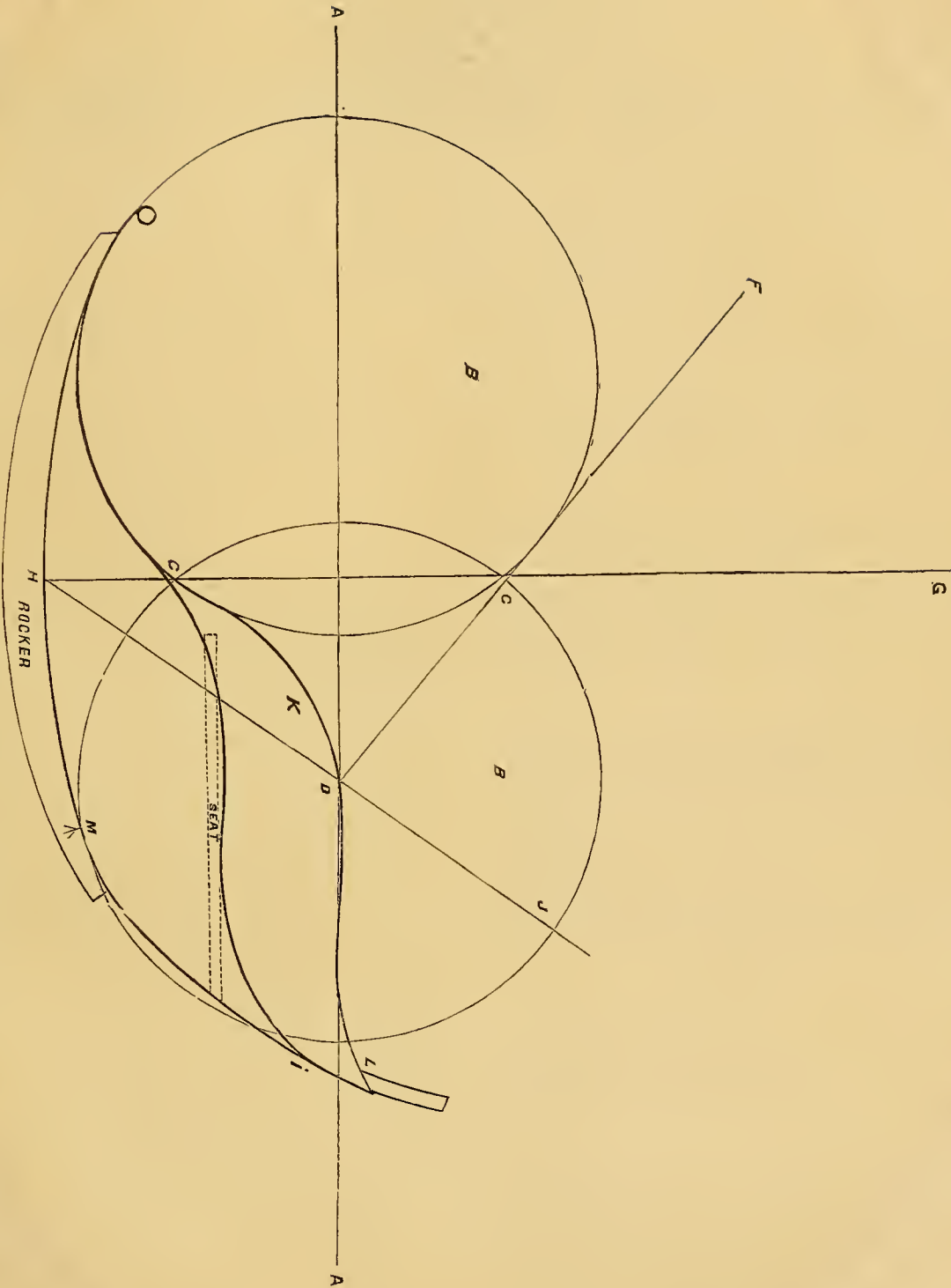

A GIG BODY GEOMETRICALLY DRAWN.

*Explained on page 73.*





DEVOTED TO THE LITERARY, SOCIAL, AND MECHANICAL INTERESTS OF THE CRAFT.

Vol. V.

NEW YORK, SEPTEMBER, 1863.

No. 5.

## Mechanical Literature.

### THE TIREVILLE MISCELLANY;

BEING SELECTIONS FROM THE PRIVATE JOURNAL OF JOHN  
STILWAGEN, ESQ.

BY THE EDITOR.

(Continued from page 34.)

As intimated in a previous paragraph, the references of Hardface having given his character a favorable coloring, I was induced to sell him a carriage, taking in payment his note, payable in bank at sixty days. To my astonishment, when his note matured it was protested for non-payment. On further inquiry, I was assured that my customer was a regular swindler—one of a clique who made it a special business, under false pretences, to rob the public. The *modus operandi* by which it was accomplished was this: Some half a dozen firms, in as many localities, and in different kinds of business, having each temporarily rented a store—pretending to hire it for the year—by a *showy* display of casks filled with water, numberless empty boxes all nicely labeled, and other things artfully arranged, made matters look as though they were doing an honest, thriving business, to the superficial observer; but when afterwards the truth was elicited, it was apparent that these different *firms* were just so many members of the one nest of fowl birds, preying upon the effects of an unsuspecting community—robbing, by means of a systematic combination, every unsuspecting individual who chanced to fall into their clutches. By a pre-arrangement between themselves, they were bound to give a *good* character for their *bad* friends in every instance where references were required of them. From the result of this transaction I have learned this lesson: Never to rely solely on the word of individual referees named by a party interested, without inquiring further of others he has not mentioned, and whose unbiased testimony confirms all they have said to his credit, unless you are willing to suffer loss. In too many instances one individual gives another a good character simply because he expects the same favor from *him* in return.

But it is not alone strangers that rob us. Sometimes this is done by professing friends. One morning a stran-

ger drove up to my shop, and handed me the following note:

MR. J. STILWAGEN: *Sir*,—Please take the carriage of the bearer, Mr. James Funning, for repairs, and send the bill of the same to me for settlement, and oblige, Yours, truly,

H. M. PEARCH.

TIREVILLE, May 16th, 18—.

Supposing that all would be well, I took the job, relinquishing any claim I might have on Mr. Funning in case my "friend" Pearch did not pay. At the end of six months I rendered a bill of \$42.21 for the repairing done; and then, after repeated calls for settlement, and as often being put off, one day I received from him the following *cool* epistle:

TIREVILLE, Dec. 31st, 18—.

MR. STILWAGEN: *Dear sir*,—In good faith I promised you money to-day, provided Mr. Muchmore paid me for getting his appointment to the Naval Academy. The appointment I obtained, and met him to-day by agreement. He said the papers were all right, but told me he must go to Philadelphia for the money, and return with it.

This stroke has made me very ill. I have no other apology to offer than the above explanation. I have no other source of obtaining the money, and must delay my engagement with you till then. I shall be at home till Saturday, and if you wish to sue me I shall be here, and you can serve your papers on me.

Respectfully,

H. M. PEARCH.

Such was the kind of "settlement" offered by "a friend," after seven months' waiting for my due. Accordingly, I put the account into the hands of an attorney, who in due time sued him. That act induced *my friend* to write me another letter, as follows:

TIREVILLE, March 25th, 18—.

J. STILWAGEN, ESQ.: *Dear sir*,—I received your complaint and summons to appear on the 30th, on an action of my indebtedness to you. The action, dear sir, will only involve you in expenses of suit. I cannot pay either. I am willing to confess judgment, and save you costs. My creditors, some months ago, forced me to have a receiver appointed, and now I own not one dollar's worth of property in the world. I have been trying to make arrangements with my creditors, by which I shall have time given me to recover from my failure and pay my debts. I remain, dear sir, respectfully your obedient servant,

H. M. PEARCH.

Whether this was a deliberate conspiracy between *my friend* Pearch and *his friend* Funning to rob me, or a simple case of misfortune on the part of P. in the mean time, the result was the same—a loss of my money. P.,

knowing his own embarrassment at the time he sent F. to me with a note and his carriage for repairs, assuming responsibility for the payment of the bill, thereby showed a strong probability of dishonest intention on his part from the beginning.

In my experience I have found one class of customers very tricky in a small way. They would warmly resent being called robbers, and scornfully repel the charge of being thought mean, yet they really combine both characteristics in one and the same person. For instance, a man will call upon the carriage-maker with a carriage, and get his "lowest price" for doing certain repairs, every item of which he is careful to mention, and the amount charged he is particular to note. Before he leaves the shop he remarks, "Now I shall *expect* you to put my carriage in first-rate order." Unless the carriage-maker is very particular with such customers, trouble will follow. He *expects* what you don't *expect*—to get work done other than he has specified for the price originally stated. I find the easiest way to get along with this class of patrons is to have everything on record at the time of taking the order, then, should they afterwards want *extra* work done, their "expectations" may be met with charges for *extra* pay.

*April 23d.* Was told by one of my workmen, whom I hired last autumn on contract for a year, when business was dull, that I could afford to pay him higher wages, and that if I did not do so he must leave me. It appeared that my Scrabble-hill competitor had offered him twenty-five cents more per day than I was paying. This—I am sorry to say such is the case with many of our journeymen—was enough to induce him to leave at the most busy time of the year, regardless of his obligations, and to the sacrifice of principle. In this case there was no remedy, because there was no responsibility involved on his part. Have made up my mind that hiring men with an understanding that the job is a steady one for a year is all folly; an unprincipled, irresponsible man never looks beyond the present, and is ready to *bite* at any tempting offer, wherever such is presented, regardless of consequences.

*May 4.* I had a customer who sometimes bought of me carriages to sell again, but who had heretofore always paid his bill when taking away the job. This practice had continued several months, when one day he came and purchased a carriage, paying a portion of the amount due me, but expressing himself as being "short," saying that if I would take his note for \$120 for 20 days he would not only pay at maturity, but I would very much oblige him. In view of his former punctuality, and fearing to lose his custom, I consented. Need I say that by so doing I not only lost *his* custom, but likewise the sum trusted. The note at maturity was protested and repudiated. On inquiry I found he had played the same game among other carriage-builders. I have recorded this as another one of the *beauties* of carriage-making, not because the practice of giving credits is peculiar to that business alone, but because it is of such a nature that, in order to make sales, the craft are too frequently induced to trust without using necessary caution; it would appear, sometimes, as if merely for the sake of *doing* business. Is it, then, at all strange that we so often hear of their being "sold?"

(To be continued.)

## ANCIENT ROMAN CARRIAGES.

BY THE EDITOR.

(Continued from page 52.)

THE *Carruca* was introduced at a later period than the *Carpentum*, and is mentioned by Pliny, 33, 49; but so little is known of them that antiquarians are uncertain whether they had only one wheel, like a wheel-barrow, or, as is more probable, four wheels. This much, however, is known: that they were first-rate vehicles, ornamented with gold and precious stones, and that the Romans considered it an honor to ride in those that were hung remarkably high. In the Theodosian Code, the use of them is not only allowed to civil and military officers of the first rank, but commanded, as a mark of their dignity. See Codex Theodos. lib. xiv., tit. 12; and Codex Justin. lib. xi., tit. 19. These *carrucæ* had a frame made either higher or lower. If designed for show, it sustained an elevated weight; if for sleeping, the body was hung lower.

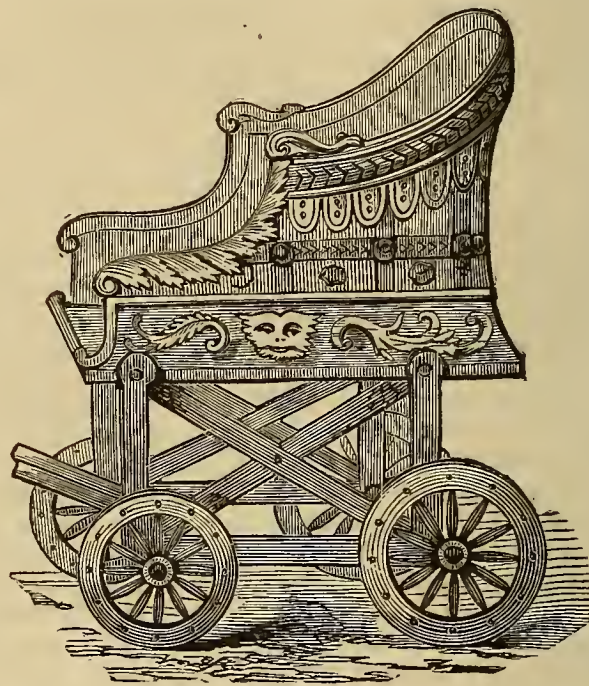

Fig. 3.

The name *carruca* was derived from *currus*, the Latin for chariot, which our readers have already seen was in use long anterior to the Roman empire. From this word *carross*, *caroca*, the English word carriage is derived. The *carruca* is supposed to have been originally made open, as in Fig. 3, for Horace says it was like the *Pilentum* and *Apene*. According to Ammianus, "it was a great thing to have a four-wheeled *carruca* built higher than the rest, for in these they could be seen better than in the others." Extravagant sums are reported to have been expended in decorating the *carruca* by the wealthy Romans. Martial, in one of his epigrams, tells us that this vehicle, in some instances, "had cost a country estate." Suetonius, in his life of Nero, says that tyrant, in his journeyings, never had less than three thousand *carrucas* in his train, and all the mules drawing them were shod with silver. The passion for splendor and show among the luxurious Romans raged so high that, in order to check the evil, severe measures were adopted; and, on

a certain occasion, when a costly and richly decorated carriage was offered for sale, the Emperor Claudius ordered it to be purchased and broken up, to deter the wealthy from continuing their injurious indulgencies, detrimental to themselves and the interests of the state.

The *Rheda* was another carriage, used for a great many purposes. Cicero, in writing to his friend, says, "*Hinc epistolam dictavi sedens in Rheda*" (*Cic. Att. 5, 17*); and we learn from other authors that they were employed in conveying materials of war, money, and other goods. This was like the *carruca*, a clumsy vehicle, but capable of carrying many passengers. The Theodosian Code ordained that this should not carry more than one thousand pounds weight, and that eight mules in summer and ten in winter should be yoked to it. Constantine also ordered that no one who traveled on public business should dare to demand the oxen of the peasantry, but employ those only kept for the public service. There appears to have been several kinds of the *Rheda*—as the Military or State *Rheda*, the Post *Rheda*, and the Private or Family *Rheda*. These appear to have been of Gallic invention, and adopted afterwards by the Romans. The frame of the carriage, as well as the two-wheeled car, was called *Rhedig*—the body of the car resting on the axles, and fastened by four wooden pins or bolts, with a simple pole secured to the axle, as in the ancient war chariots of Assyria and Greece.

The State *Rheda* was strongly built, and, for security, was enclosed all around, to protect the occupants from danger, or to ensure the safety of goods and moneys. Like as with the *Carruca*, it was decided by law that "when gold or silver presents shall be sent, the *Rheda* shall not carry more than 500 pounds of gold, or 1000 pounds of silver;" and further, that "only the finer apparel and the linen necessary for use to the weight of 1000 pounds shall be carried by the government. Unlike some monopolies of the present day, conveyance in these government vehicles was perfectly safe, and goods entrusted in them were seldom lost. This was a slow conveyance.

The Post *Rheda* was evidently a lighter carriage, and a much more expeditious vehicle of travel. Suetonius, in his life of Cæsar, before referred to, says—"In a hired *Rheda* he made the longest journeys with extraordinary rapidity, going daily a distance of one thousand steps," or nearly ninety-five miles. From various authors we learn that these Post *Rhedas* were easy and comfortable, the seats being hung in straps, and furnished with soft bolsters and pillows. They were regularly stationed in sufficient numbers at the post-houses for the public convenience. Thus the military, public officers, couriers, or private persons, were furnished with every necessary convenience for business or travel. Special laws were instituted, that "when a district selects deputies, to whom their designs have been confided, they shall be provided for their accommodation with a *Rheda*." *Theod. Code 9*. Cicero, in the passage previously quoted (*Cic. Att. 5, 17*), leads us to infer that it was common to write letters in them, or at least that it was possible to do so, did occasion require it.

The third class, or Family *Rheda*, is alluded to by Juvenal. Martial, also, in his Epigram on Bassus, describes an epicurean as "driving from his country estate

into town in his full *Rheda*, bearing all the fruits of this blessed earth; you might have seen the broad lettuce, the onions and garlic, and the cabbages, not unsuited to the delicate stomach; near them lay a garland of fat field-fares, a hare wounded by a dog, and a sucking-pig.

This vehicle, shown in Fig. 4, is hung very low on the

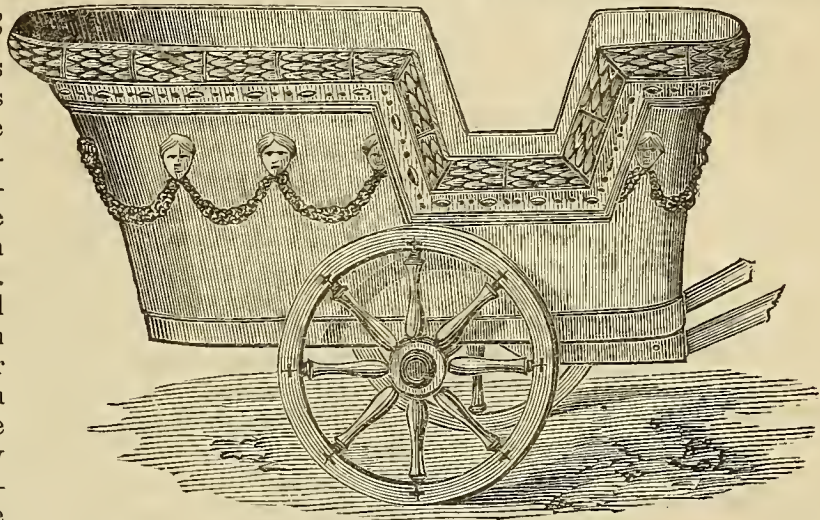

Fig. 4.

axle, and, for convenience, is made low in the middle of the side through which the passengers enter. They are supposed to have seated six persons, three on each seat, with ease. It appears to have been richly ornamented. These must have been real horse-killers, when hung on two wheels, as we see in the engraving.

According to Paulus, the *Rheda* must, in some instances, have been supplied with a covering, for he mentions various articles as being necessary to furnish a traveling equipage, "as a carpet for the feet, the soft packing skins, straps, and the linen cover to spread over the carriage." Pliny relates that he made a journey to Rome in a *Rheda*, with great comfort. "The stout leather surrounded and curtained it securely from the wind and frost; while the latticed windows, with their linen blinds, let in the softened light, and the well filled bolsters covered the easy seat." The frame work, or bows for the top, were made of birch poles, bent to an arch, and extending across the body, as in our common grocery or business wagons. Although very clumsy in the judgment of a modern coach-maker, still the *Rheda* must have been a superior vehicle, compared with the *Carruca*, or its adoption from the Gauls would not have taken place, and, when used as a pleasure vehicle, it was, no doubt, highly ornamented. The vehicles thus far described must be pronounced unwieldy, and, like everything else Roman, too clumsy for general purposes.

(To be continued.)

## THE MOTIVE-POWER OF WHEEL-CARRIAGES.

BY H. H.

(Concluded from page 50.)

AXLES and boxes should be hard enough to crush the sand and resist the tendency that sand would have to indent itself into the iron of the same. The bearing should be made to extend equally over as much surface of the axle and box as it can. It is a mistake very commonly entertained by the craft, that by lessening the bearing surface we lessen the friction, which has grown

out of the fact that by lessening the diameter of the axle and box, we increase the leverage of the wheel. A great mistake is made by axle makers, also, in leaving chambers in the box to hold oil. This has no other effect than to leave a less bearing surface, so that the particles of iron from the box and axle, interlock and break off sometimes to such an extent, that the bearings heat in that part of the axle. We have seen one of the many varieties which the caprice of axle makers had established for oil chambers, where a groove was made about one half of an inch from the large end of the box to extend around the box. The effect was in this instance, and will be found the same in other cases—that the large end of the box wore out the fastest, also the axle wore off, leaving a groove to fit the bearing of the box, which inclined the bottom of the wheel more under the wagon, and this increased the bearings on the large end of the box, so that it was worn out to such an extent, that it needed overhauling after four months' use. One year would have spoiled an axle, that, if it had been made without oil chambers in the box, and if the axle had been set so that the bearings would be equal at both ends of the arm, would have lasted without repairs, as long as the best buggy that could be made. The oil chambers had an effect contrary to what was expected, for that part of the arm was the first to get dry and burn up the grease.

It should be borne in mind by axle makers—and every practical test will prove the same—that no better chamber to hold oil in reserve, to supply the place of that which is consumed, can be, than the upper side of the axle arm where it always has a tendency to run down to the lower side of the axle, and spread on to the bottom of the axle arm in the very place that it is needed. *The bearings of the axle arm and box should never be raised any higher in one place than another throughout the whole length of the arm.* This proposition will be denied by many who have been long accustomed to rack their brains in finding out some new shape to put an axle into, in order to secure more strength, and a reserve for the oil to deposit itself into; but I am well advised whereof I speak, both practically and theoretically, or I should not say that which will be so unpopularly received.

Another error which is common, is a way contrived to keep the sand from getting into the axle box. A shoulder is made for the collar to the axle, which is one inch more in diameter than the axle arm, and this shoulder is received into a tight fitting box which makes it a part of the axle and box. There are two reasons why such an arrangement should not be used. The first is, that it makes a bearing for the shoulder of the axle arm which it is almost impossible to keep oiled with the other parts of the axle, on account of there being more friction at this raised point, which consumes the oil faster. The second reason is, that it destroys a part of the leverage to the wheel, the same as enlarging the axle would do, and which has been previously described by the lever lines. The best way to keep sand from getting to the axle arm, is to fasten at the collar a thin piece of iron that will nearly fill the surface of the large end of the hub, and have the band on the large end of the hub extend over the end of the hub; this shuts out almost every possible chance of sand getting to the axle arm. This way has been tried on stage coaches with perfect success.

The kind of oil to be used for lubricating an axle is

an important consideration. There are a great many notions entertained on this subject, some of which must be wrong, as they are contradictory. To determine right from the wrong will need some theorizing on the nature of the different kinds of lubricating matter used. We see when the oil is put on the axle, and the carriage is put into use, after a few days it will require more oil, and then again, after a few days more, requires another application. The question is, what becomes of this oil? The superficial observer will say, perhaps, that it runs off, or is absorbed by the sand and dust that it comes in contact with, or some other excuse—at any rate, it is gone.

There is an immutable law of nature, which, if examined, accounts for the disappearance of the oil, and also shows the difference in quality of different articles as a lubricator. This law is the destruction or decomposition of all animal and vegetable, and nearly all mineral matter by oxygen, sooner or later. Some are decomposed in a short time, others, comparatively speaking, remain much longer. Oil mixed with matter of a glutinous or resinous nature invariably has the oil destroyed first by the oxygen.

We have stated before that lubricating was simply placing a thin substance between the two substances that rub together, which keeps the particles on the surface from interlocking, and thereby breaking off and creating heat. By spreading oil out in the way it is done on an axle exposes a large surface to the action of oxygen, which is in the atmosphere, and which consumes the same, so that it wants replenishing soon, to form a lubricator. Now let us use linseed oil for a lubricator, which is composed of two substances, one an oily, the other of a glutinous nature, which oxygen will not act upon near as quick as it will on the oil. The consequence is, the oil is consumed first, and the gluten is left for a lubricator, which gums up the axle so that it is nearly as bad as if it had no lubricator. The same effect is had from the use of flour with oil, which is often recommended. The carbonate of iron (black lead) with oil has a similar effect. Coal tar with rosin operates in the same way, and all combinations of substances, where one will be destroyed by oxygen sooner than the other, will make a poor lubricator, as the part that is left will form a gum which will make the axle and box adhere together. On the other hand, pure castor oil, in which all parts are decomposed alike, forms one of the best lubricators. Good olive or sweet oil would be good. Hog's lard does well. Tallow is not as good; on account of its hard nature, it is deposited on the upper side of the axle, and requires more heat introduced to the axle by friction to remove it from its place than is safe to have about an axle. When an axle is oiled it is best to remove the old oil that has been worn previously, with a rag, as it is a great chance if the same is not gluten deposited from the previous oil. Here we may notice the effect of heat on the oil, which is oxygen generated by friction. This is always created by concentrating a disproportional part of the load on to some one part of the axle, either by making the bearing unequal, or by making the bearing surface so small that the oil is actually crowded out from the two parts of iron that come together, allowing the surfaces to interlock and create heat, as has been previously described. The part of the axle which receives this disproportionate bearing becomes heated, as before stated, to such a degree sometimes



as to weld the axle and box together, and, of course, so that the oil is completely consumed.

If such occurrences could not be easily avoided by a proper study of the laws that govern the operation of of wheel-carriages, we should be more excusable than we now are for their existence. But when we take into consideration the very true saying, that "many mechanics receive their *money* and *ideas* from the same source," it is not at all to be wondered at that we have such a diversity of opinions about facts that in the nature of things can have but one true construction put upon them. The mechanical laws are the immutable laws of God, and admit of no two constructions. Are we entitled to the honorable name of MECHANIC, when we give so many and contradictory constructions to the laws that govern us?

We started this subject with a mathematical calculation, which we believe was as near correct as could be made from the data given, which showed that perfect wagons, with the same motive-power, would earn in the same space of time from one hundred to two or three thousand dollars more than imperfect ones, according to the degrees of imperfection which they possessed. Can it be possible that there is a set of impostors in every town, village, and city, that are ignorantly taxing their fellow-citizens with this enormous amount of work? It must be so, or else figures lie. Since I began writing on the subject—nearly two years ago—I have visited various shops in the section of the country in which I live; and, wishing to benefit those whom I have visited, and encourage the literature offered to our craft, I have solicited subscriptions of those who were acting in the capacity of mechanical wagon and carriage-makers, and exhorted them to patronize the only work devoted exclusively to their business in the United States. Perhaps one in five were ready and glad to get information that they could make beneficial to their customers and themselves, the other four-fifths proved to be careless about it. It will be interesting to know as much as we can about these two classes—how they succeed in business. First of all, I will say that I have never known a man who has subscribed liberally to THE NEW YORK COACH-MAKER'S MAGAZINE, but what has been prospered in a remarkable degree. On the other hand, those who have "*wanted to take it, but really could not afford it at present,*" have been on the decline in business—some have fizzled out completely (all tending that way), and it seems only a "question of time" with them, as it should be, for truth and justice must prevail, and the community cannot bear this intolerable burden which is put upon them by a combination of stupidity and knavery in those who are miscalled mechanics.

I cannot take leave of a subject on which has been bestowed facts that have taken a lifetime to accumulate, without adding this last advice and warning, which are equally as important to the business relations of the mechanic as anything I have said is to his mechanical skill. Let us all strive to lay before the craft one true mechanical theory by which it may be governed. If we do not, our names will in a measure become identified with the class who are a disgrace to the name, and the compensation that we receive will be nearer to that of the man who is a perfect ignoramus in his profession. Nothing makes us more contemptible, and our business more unprofitable, than the great anxiety that some have to "hide their light under a bushel." Let every one who claims to belong to

the mechanical fraternity of carriage-makers show his title to such claims by willingly contributing his share to support a periodical where the theories and facts which members of the craft may entertain may be recorded and scientifically commented upon by other members. Make it your business first, after subscribing for this Magazine, to see that your neighbor does the same. If he refuses to do it, then your duty to the community which he pretends to serve is discharged. Depend upon it, the blunders he will make will deprive him of the ability of competing with you long in a business that requires knowledge to keep up with the times.

---

FAITH WHISPERS.

BY ANNIE M. BEACH.

O FATE! draw the veil from my future, I said:  
Let me look only once on the years that shall be.  
I am dreaming a dream,—a wild, beautiful dream;  
But its waking is hid in a dark mystery.

Look away to the field where the foemen have met,  
And tell me who stand and who fall in the fray!  
And who shall return to the homes they have left,  
When the sunshine of peace breaks the war-clouds away!

Our fair flag shall fly where the traitors have trod,  
And our land be the home of the happy and free.  
But go to the hillocks where slumber the slain,  
And tell me the names of the dead that ye see!

Then there fell on my ear a sweet voice from afar:  
"O, Christian, confide in the love of thy God,  
Nor question of Fate who shall stand in the fray,  
Or who with the sleepers, lie under the sod.

"Take no thought for the morrow, the present is thine;  
To-day, from His bounty, thy wants are supplied.  
And the promise is sure to the faithful and true,  
Sufficient thy strength for what'er shall betide.

"Not one sparrow, unheeded, shall fall to the ground;  
And are not His children more valued than they?  
And will He not now, as in days of the past,  
Give ear if, in faith, nothing doubting, they pray?"

Then I said, it is well; in His record I read,—  
"Seek first in thy young years the Kingdom of Heaven."  
And I know the dear promise He left cannot fail:  
"All else that thou needest shall surely be given."

CAMBRIA, N. Y., June, 1863.

---

EXCISE LICENSE ON CARRIAGES IN ENGLAND.—The recently laid income-tax being a novelty in this country, what follows will be of some interest to our readers. In Great Britain, persons letting post horses and carriages, for a single horse and carriage pay an annual license of \$37.50, with seven rates to twenty horses and exceeding fifteen carriages, when the license is \$350, with \$50 for every ten horses, or fraction thereof beyond. For the same in Ireland \$10.50, and five per cent. thereon. The license to run a stage-carriage in Great Britain is now \$16; to keep a hackney-carriage in London, \$5. In addition to the license for running stage-carriages, an additional duty of two cents per mile is levied. During 1862, 6,215 hack-carriages were licensed in London, amounting to \$455,900. In Great Britain, 3310 stage-carriages were licensed, amounting to \$632,090. Considerable decrease has taken place in both hackney and stage-coaches in the past few years.

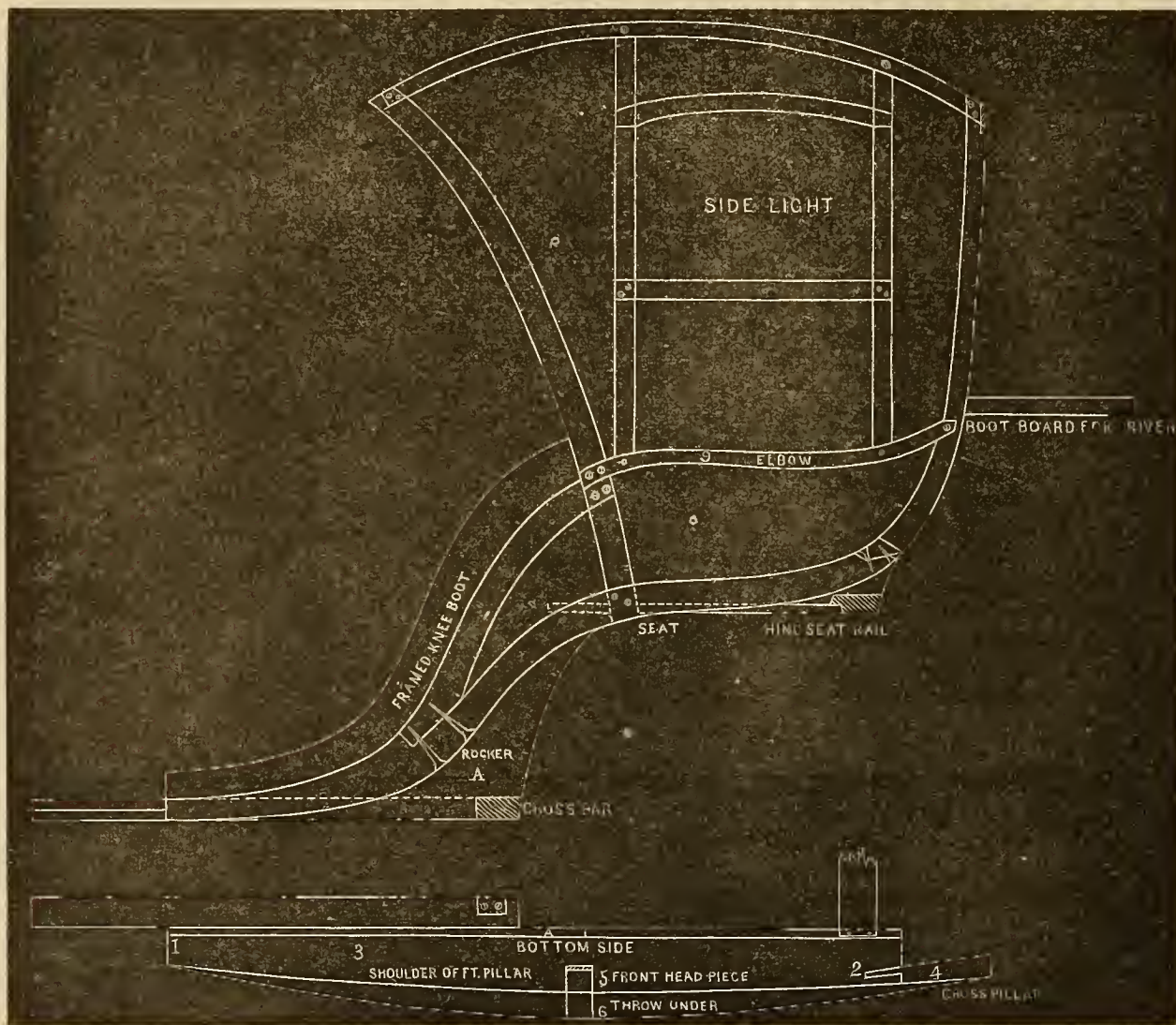
PRIVATE HANSON, WITH CANT-BOARD.— $\frac{1}{2}$  IN. SCALE.

## ENGLISH CARRIAGE ARCHITECTURE.—No. XII.

FROM fig. 1 to 2 shows the extreme length of the body from the front bar to the joint of the hind corner pillar. The line (fig. 3) shows the toe of the front pillar. Figure 4, the hind corner pillar. Figure 5, the front head-piece, where it is framed into the bottom-side; the lines 1, 4, showing the outside of the body at top, the distance between 5 and 6 being the extreme length. A shows the rocker, and figs. 7, 8, 9, distinguish the different parts of the body as marked.—*Car. Build. Art Jour.*

## OLD ROADS OF OLD NEW YORK.

BY THE EDITOR.

NEXT to that of a good carriage and horses, the pleasure-seeker desires a good road for travel. It may interest some of our readers who drive over the Fifth avenue and Bloomingdale roads at the present time, to hear something of the old roads of *old* New York, for the principal facts of which we are indebted to Valentine's Manual.

The old Harlem road, so long a favorite thoroughfare for fast drivers until it was occupied by a railway, at the same time spoiling the road and ruining the inn-keepers along the line, was a very poor one previous to April,

1671, when it was decreed, that: "Whereas, the road between this city and the village of New Harlem is impassable, and it is necessary a road should be maintained, it is ordered that the overseers of roads and the magistrates of Harlem lay out a suitable road, and that it be made by the inhabitants of Harlem, in conjunction with those living on the other side of Fresh Water (Collect Pond), each within their respective limits." One year afterwards, the complaint still was that "people lately wishing to travel over that road on horseback, have been in danger of loosing their lives by the bad

condition of the road," and that, unless the work was performed at once, those interested must be fined for neglect. This had the desired effect, and the road was finished in 1673.

In 1707, in pursuance of an Act of Assembly, commissioners for laying out highways reported the plan of the road to Harlem as follows: "To begin at the Spring Garden gate [Broadway near Fulton street], to the Fresh Water, the course being east by north [the present Chatham street, then 82 feet 6 inches wide]; thence, by a small turning, to the tree in the highway upon the hill (head of Chatham Square), so along the lane (Bowery) to the furthest house in the same, the course being about north-north-east; from the said last house, the road to run along the fence upon the right hand, as the road now lies to Kip's Runs (the brook emptying into Kip's Bay, East River). From thence, north-north-east, to the bridge beyond the hill; from thence to the corner of Turtle Bay farm to the top of the next hill, about east-north-east; from thence to the Sawkill bridge, north-east a little northerly; from Sawkill bridge along Mr. Codrington's fence to the half-way house, about north-east; from the bridge by the half-way house, the road to turn to the right hand, and so over the creek to Harlem." At this time, the only bridge across the Harlem river was the Kingsbridge on the Hudson river side of the island.

The Kingsbridge road, which was resurveyed in 1707, about the time of opening the Harlem road, connected at the half-way house previously named, and "from thence it runs along the lane to the next hollow, about north; from thence to Meyer's, north-east, and thence to the run by Barent Maldron's, north-north-east; from thence along the fence, and so by John Kierse's house, on the right hand, and so along as the road now lies, leaving the run of water on the left hand, until you come to the deep bridge; from thence along the foot of the hill, which is to the left about half a mile, then turning to the left, and leaving the swamp on the right hand, as the road now is, unto Nagel and Dyckman's farm; from thence, as the way now lies, leaving the fence on the left hand, through the ground of the said Nagel and Dyckman, by the house where the said Dyckman doth now live, and over his bridge, and so forward, as the road now is, unto Kingsbridge, the main course being north a little easterly."

The Bloomingdale road, now so popular with the seekers of pleasure during the summer season, was laid out in 1707. "From the house at the end of New York lane (present Bowery), turning to the left hand, the course being northerly, and so by Great Kills, and forward, as the road now lies, unto Tunis Edis's and Captain De Kay's, through said Edis's land." In 1760, a road was surveyed and established to run from Greenwich to intersect Bloomingdale road four rods in width, and was constructed at the expense of the corporation. This led past Captain Clarke's large mansion, called Chelsea.

Another road, called the Monument road, at the period before mentioned, led along "from Rebecca's house, in New York lane (Bowery) to Greenwich, said road running to the leftward of the house late of Captain Doume, deceased." Another road leading to Greenwich along the North river, was established about the year 1730, extending north from Canal street to the village of that name. This lay upon the line of the present Greenwich street. At the period of which we write, communication with Albany was very irregular. As late as December 6, 1747, we find it published that "Cornelius Vanderbergh, as Albany post, designs to set out for the first time this winter, on Thursday next. All letters to go by him are desired to be sent to the post-office or to his house, near the Spring garden," situated at the corner of the present Fulton street and Broadway. If the road beyond Kingsbridge, all the way to Albany, was as crooked as that portion within the limits of Manhattan Island, "Cornelius" must have had a tedious journey in reaching the end of his route. This was undoubtedly done on foot, as, a few days previously, the following appeared in the public prints: "Whoever inclines to perform the foot-post to Albany this winter, is to make application to Richard Nichols, Postmaster." At the same time notice was given "that the Boston and Philadelphia posts will set out in future to perform the stages once a fortnight during the three winter months." These two last mails had already been established 37 years. As, in regard to other matters, "*dicunt necessitatum esse matrem artium,*" so necessity has produced a great improvement in the means of travel within the last 50 years.

IVORY CHARIOT OF MYRMECIDES.—Pliny (c. 36, 5) tells us that Myrmeceides, an ancient engraver, made a chariot of ivory, with four wheels and as many horses, of so small a compass, that a fly might cover the whole with her wings.

## Home Circle.

### JOURNEYINGS OF A WHIRLWIND.

BY EMMA E. BRIGGS.

WILD, merry and playful am I, a whirling, waltzing, frolicking whirlwind. Nay, start not! and let not foul visions of horrible destruction and devastation spring up before you as specters of unknown ill, for I deal not in the terrible things of earth. My vision is not to howl wildly through the tattered sails of the doomed vessel, when the "Storm King sullen roars," and the lurid glare of the lightning's fitful flash illumines the scene with a fearful splendor; to uproot the sturdy, far-spreading oak—monarch of the forest—or to sweep the humble cot of the mariner from the lonely sea-side where it stands. No; far, far removed from this is my nature, for I delight not in human wo; I am the welcome, joyous whirlwind of a summer's day—free and fetterless—alone unconquerable. I journey over the fair earth, scorning troubles and trials, soaring above them all; I have no abiding place; but where my fancy leads me, there is my home. Capricious am I, as the veriest fop that ever twirled a moustache, or swung a cane; but my principles are purely republican. I toy for a while with the jeweled tiara of the crowned head; then away, and scorn not to refresh with my joyous breath the playful cottage child. With pure delight I flutter in her path, kiss her bright cheek and coral lip, till, as the charm of novelty departs, with a blinding shower of flaxen curls, I bid her fair face adieu.

My early home was in a fairy-glade, where the wild and beautiful were strangely mingled. Gigantic rocks, their rough sides tapestried by the bright hued mosses, reared their lofty heads deep in its hidden recesses, where human foot had never trod; sublime in its wild, unsubdued grandeur roared the mountain cataract, where the dark pine and gloomy cypress mingled their foliage, and the deadly night-shade curtained their trunks. Over a noble elm a wild grape-vine crept, with slow, but certain pace, while the old tree paled in its embrace, and the ill-omened night-bird shrieked dismally in its withering branches. In other fairer spots, the gentle minstrelsy of the summer-rill was heard, as it wound through the cool, calm glen, and the graceful willow and the trembling aspen waved lovingly over the snowy lily of the vale; and the modest violets dotted the green-sward with their tiny forms, while the scarlet berries, peeping from the rich green of the clustering vine, lent new luster to the charmed spot.

Such was my home, and happy was I in the joyous summer, gossiping with the flowers and warbling with the birds. I listened to the secrets of the pretty blossoms, then softly whispered them to the tall, green trees; and many were the tales of love and hatred, joy and grief, I heard, and even of foul envy that had intruded there. The crimson rose faded to a paler hue as I waltzed along near a tulip-bell of beauty rare, and the proud lily looked scornfully down as I raised the graceful head of a blue-eyed violet—the chrystal dew-drop still trembling on its breast. I learned of the timid aspen the cause of its shuddering; but strove in vain to descry the innumerable spirits whose breathings so gently swayed its leaves. I

taught the meek sapling to bow in submission to the haughty oak; troubled the ripples of the little brook, and scattered the perfumed petals of the blooming flowers. But sad, sad was I, and piteously I sighed, when the trees were all divested of their summer drapery and dared, with their leafless boughs, the storms of heaven, or supported winter's gift—the fleecy snow. I loved not his stern reign, when the lovely evergreen was forced to surrender many a green branch to the fury of the blast, and the tall pines bowed to meet the coming tempest, and moaned as they struggled with the mighty.

In terror at such a time, I escaped from my companions, the whirling eddies of the ocean of air, and hid down deep in a fairy cavern of moss-covered rock. For three long, weary months I lingered there; but, when the sun began again to melt the snow upon the hill tops, and the trees welcomed the soft breezes of the "sunny south," the tiny buds threw off their green enclosures, and, gladly beautiful in their unsullied purity, burst the scenes of nature upon my sight, I fluttered forth again upon my joyous mission. But the brook rippled lazily; the leaves hung as if lifeless on the trees; even the clear note of the gentle wood-bird was hushed; a dull, heavy languor seemed to pervade all nature; strange and wildly beautiful was the scene,—but sad and solitary—and I longed for the sound of a voice.

Bidding adieu to my early home, I started up; whirled a merry farewell waltz in the little rivulet, raising its hum-drum song to a joyous note; whistled a frolicsome tune on the budding foliage of the old trees, and glanced gleesomely away. I passed near a mountain cataract, where a happy group was gazing on the beauteous scene—all was to me bright, charming novelty, and crazily I frisked about, abandoning myself to the spirit of mischief and fun that had taken possession of me. Away I whirled, compelling all that crossed my path to join in my frantic waltz. I plunged headlong into the foaming waters, scattering the sparkling drops of crested spray into a thousand fantastic forms—bore them upward to sport for a while, then flung them in a diamond shower upon the merry ones beneath. I seized the hat from the cranium of the fashionable beau, and led him a merry chase—now tossing it triumphantly upward, then placing it meekly upon the ground, just within the reach of his extended arms; but, as he grasped the smoothly polished surface, I whirled it far away above the old tree tops, till, wearied with the sport, I allowed him to recover his treasure. In compassion, I breathed a reviving draught over his rueful visage, not exempting his nicely adjusted hair, and left him mournfully contemplating the wreck I had made. Next I frantically fluttered the ribbons and ringlets of the laughing girls, and bore off victoriously, amidst shouts of glee, the fairy scarf from the vanquished belle, leaving it fluttering with provoking grace on the top-most branch of a stately elm.

As I frisked through a little village, I swept over the spire of the old church, shaking the tottering, moss-bound fabric until it rang forth a merry peal on the tiny bell within. The streets were crowded by all ages and sexes; the aged grandfather, bearing in his arms the happy child; the gossips, in close and earnest confab as to the unexpectedness of the event; the pretty, shy, country lass, who twenty times a minute wished herself a bride, and the bell pealing for the wedding; the consequential doctor, sporting with professional gravity his gold-headed

cane; the schoolmaster, who had given holiday for a summer ramble, followed by his noisy troop; and the sharp-visaged lawyer—all mingled in the throng, and turned toward the church on the summons of the bell. "Ah, ha!" whistled I, as I frolicked madly among them, "may your walk refresh you all;" then left them standing in sore dismay at finding the old church doors as tightly shut as if never made to open, and not a creature stirring about. What a fine goblin story of verity and truth will all this make to descend to the village posterity.

Onward I hurled in my untiring waltz, speeding madly around; rudely ruffling the silvery bosoms of peaceful lakes, and scattering the crystal-drops from fairy forests; but nought had charms to arrest my progress until I frisked through a grand old wood. With bright memories of my forsaken home, I sought my favorites—the hardy oak, the stately elm, and the tall pine—each standing in haughty majesty before me. I hummed a song of gladness, as I wildly tossed the leaves of an aged oak that reared its giant form over a frightful precipice. The untamed lightnings had done their work upon it, and the stately tree had not remained unscathed; yet it was stern and unbending to my gay, joyous advances. "You shall yield, you shall yield," whistled I; and, gathering all my strength, I compelled the old tree to dance merrily and gladsomely with me. Round and round sped the far-spreading branches, till the stiff, dry limbs, as they creaked and snapped, seemed to plead "spare the old." I left it nodding slowly o'er the precipice, in dignified surprise at my sudden departure, and glanced to the meek saplings opposite. I whirled wildly through them, and the young things ambitiously strained every nerve to time with me in the lightning mazes of my frenzied waltz; but I was away as suddenly as ever, leaving the old and young bowing humbly to each other, and, in the distance, right heartily I laughed, as I caught the words—"that frantic whirlwind."

On, on I sped, scattering glee in my path, ever longing for new objects for my pranks, not hesitating to hazard a little mischief for the sake of sport, till I spied a sylvan spot, where the "Court of May," in all its regal splendor, was assembled. One worthy of her high state ruled with most gentle, queenly sway; bright was her beauty, and every heart bowed to the witching power of her charms. The elfin sprite of Mischief bid me do homage to her majesty, and, as I advanced, I swept the dried ground, gathering a dense, dark cloud of dust around me, and hurled it as an offering at her feet. The effect was magical; in one moment the throne was kindly left for my undisputed acceptance, and fairy feet were swiftly flying over the green-sward to the vine-wreathed cottage beyond. Determined not to be despoiled of my fun, I started up, gave a merry chase to the fugitives; seized the lightly-woven fragrant garland from the brow of the unfortunate queen, and suspended it high on a tall May-pole, in token of victory. Whistling a gleesome "good-by," with a mad whirl I passed on.

Now, as I flew along the narrow road, the houses began to appear more settled and close together, and, in the distance, the busy hum of the city was faintly heard. Nearer and nearer I approached, till the sound of heavy wheels on the stony pavements became discernable; long, even streets lay before me, and high, towering houses, whose frowning walls seemed to tell their utter detestation of anything like fresh air, rose threateningly on either side. I

frolicked along the crowded thoroughfare, novelties greeting me at every whirl, till the noise and confusion, and the immensity of everything around me, seemed to stupefy me for a while; but soon my good genius, the mischief sprite, reminded me that there was an infinity of sport for us near. Instantaneously I regained my wonted vigor, and swept madly by, rattling the shutters, creaking the signs, flapping the awnings, and fluttering alike the lady's silks and the beggar's rags, as I passed. Soon I approached a dark, gloomy building, and, peering into its high windows, I beheld one of that poor, dispirited, persecuted race, denominated "editors," preparing his copy for the press. Surrounded with mail-bags, old manuscripts, and other signs of his vocation—not forgetting the immense shears—he sat, one hand supporting his haggard cheek, large drops of perspiration standing on his careworn brow, and his hair partaking of his anxiety, each one had assumed a position on its own individual responsibility, without the slightest deference to order. Behind his ear lay a pen which ever and anon he wildly grasped, his eye fixed on the MS. before him, making an erasure here and an interlineation there, and occasionally clipping a select paragraph from an exchange paper and placing it with the rest on the table before him. Gradually higher grew the pile and deeper his perplexity, till I could bear it calmly no longer, and breathed a fervent sigh of sympathy in at the window. But, alas for my good intentions! Mischievous would prevail, and scattered the consecrated pile, the fruits of his faithful, industrious shears. Away they flew, pell-mell, in dire confusion, and, as they fluttered towards the window, methought I descried, "Murders," "Horrid Accidents," "Accounts of the rise and fall of stocks," "Marriages," "Deaths," "Famine in Lancashire," Wars and "Victories," all in one promiscuous mass, bidding an adieu to the victim of a Whirlwind's Frolic. Half sorry for the mischief I had done, I gazed upon him as he sat, a picture of hapless, hopeless despair; his large grey eyes glaring with unutterable anguish and glassed with horror; his arms elevated to an angle of nearly forty-five degrees with his body; his sallow cheeks sunken, and his mouth half opened as if to utter an oath, when, palsied with horror, it died unspoken on his lips.

On then I passed, and woe to the unlucky wight who should fall in the way of my crazy evolutions, as whirling, whistling, waltzing, dancing, everywhere I sped on, till wearied even of my own mischief, I sought rest in a winding river that skirted the city. Twilight was creeping slowly on, and the blue waves glittered brightly in the calm sunset, entangling in their silvery bosoms many a ray of beauty. I plunged joyously into the clear waters, tossing high the sparkling gems and sporting with them far above the envious waves, entwined them with myself. The gorgeous radiance of the rich beams of sunlight, as they faded away, imparted their crimson hue to the crystal drops, and brightly beautiful was the scene; but soon the glorious sun, as he slowly retraced his steps to his far-western home, was lost to our view—the scene of exquisite loveliness had passed away, and we quietly sank to rest in the crystal wave.

AN INTERESTING STORY.—Our fair correspondent, Lua Delinn, has written an interesting tale for this Magazine, entitled Lottie Hill, which we shall commence the publication of in our next number. It cannot but be acceptable to our readers, as others have been from the same gifted pen.

## Pen Illustrations of the Drafts.

### CANADIAN FAMILY SLEIGH.

*Illustrated on Plate XVII.*

FOR this design, as well as those that follow, we are indebted to the kindness of C. F. Hall, Esq., of Toronto, Canada West. He will please accept our thanks for his favors. It is a four-seated family sleigh, with imitation shell side, and usually trimmed with blue cloth. To this sleigh a rumble (an English appendage) is frequently attached, for the groom, although it has much the most graceful appearance without it. The price of this sleigh in Canada is from \$175 to \$200.

### PHAETON SLEIGH.

*Illustrated on Plate XVIII.*

THIS sleigh is a great favorite with the Canadians, and is seldom finished without the rumble, as it is much used by the upper classes. These seldom drive without a coachman mounted behind, particularly in the cities. This sells for from \$100 to \$125.

### FOUR-SEATED COUNTRY SLEIGH.

THIS does not differ much from some previously given in this Magazine, except in the iron work. The prices for these in Canada range from \$80 to \$125.

### TRUCK WAGON FOR CITY USE.

*Illustrated on Plate XIX.*

THROUGH the kindness of Messrs. O. Kipp & Son, of 163 Eldridge street, New York City, we are enabled to present the wheelwright portion of our readers with a perspective drawing of one of the latest improved truck wagons for city use. These may be made either heavy or light, for one or two horses, as may be required, with springs and axles accommodated to carrying from two to eight thousand pounds. The drawing, although drawn regardless of scale, yet is sufficient to enable any one with an ordinary amount of skill to build them.

### A GIG BODY GEOMETRICALLY DRAWN.

*Illustrated on Plate XX.*

THE example we present is extremely simple, and gives a very well proportioned body for Gigs, Victorias, &c., for those who have little experience in drafting. Commence by drawing line A A, next the circles B B, then lines C C, and line E, from center D through circle B. Next adjust the compass to the extreme length of the circles, and from point G draw the line H, and from point F draw the line I, then draw the line J from H through the center D; reset the compass as if to draw the circles, and draw the lines K and L from the centers M and J. In this connection we would remark that Victorias have sold well in New York this season, and are likely to be in greater demand still another year.

### COMMENTS ON THE FASHIONS.

WE noticed, during the past business season, that the New York carriage-repositories presented a greater variety, and in some instances a heavier class of vehicles than formerly, many of them of a decidedly European pattern. The prices, too, have ruled very high. This may be all very well, but to the American mind it is seriously significant. The first shows that we are fast drifting into aristocracy, and the last that the course of trade has been affected by some unusual event. A great trade has also been done in painting family crests on carriages. Where this may end time only will determine.

### Sparks from the Anvil.

#### USE AND ABUSE OF FILES.

Now that the costs of files has largely increased, it is an object of much importance to see that the most work possible is got out of them. This has been a matter too little attended to in our smith-shops generally, and should be checked, or such neglect will entail serious losses on carriage-manufacturers. Men are very apt to use them on all metals—steel or iron alike—without regard to the consequences; the result of which is they are soon spoiled. A new file should not be used on heated iron, nor on hardened steel, under any circumstances. This abuse of the article deserves the severest reprehension, and contributes in no wise to a workman's reputation, and were he obliged to pay for them, he would be more careful, instead of running so often to the boss for a new one. We need not tell the careful man that a file judiciously used will last a third longer than one abused, they know this is true; it is the careless one for whom our remarks are intended, in the hope that we shall benefit employers both in time and money. Save and have them re-cut; it will pay.

#### HOW METALLIC SURFACES ARE PROTECTED FROM RUST.

STEEL, iron, and brass may be protected against rust by applying a coat of the following compound: Take ten pounds of gutta percha; twenty pounds of mutton suet; thirty pounds of beef suet; half a gallon of sweet oil; two gallons of neat's-foot oil; one gallon of oil of thyme, and half-a-pint of rose-pink. Simmer these ingredients over a slow fire until the whole is dissolved and well mixed together. When cold, the application should be made by rubbing the compound over the surface of the metal with a cloth or leather.

#### CEMENTATION OF STEEL.

AN invention has recently been patented by A. A. Lambert, of Paris, France, according to which he claims the application of wood divided into small parts, such as saw-dust, the leaves of trees, and the envelopes of certain fruits, for the cementation of pieces of cast-iron to form steel suitable for the manufacture of wheel tires, cutlery, and other articles.

### Paint Room.

#### COMPOSITION OF PAINTS.

BY H. HARPER.

(Continued from Page 57.)

How we "live and move" among poisons—Poisonous paints very useful for some purposes; but not for decorating "sugar-toys"—Prussian blue and chrome yellow make a comparatively harmless paint—Blacks entirely so, are absorbents—The effects of the sun on black and white colors—The nature of Prussian blue, ultramarine, &c.—Ultramarine anciently more precious than gold.

CONSIDERING how deficient and ignorant men are of the composition of paints, and how much they are given to the besetting sin of making a fine appearance—to this we are all more or less addicted—it may with truth be said, that "we live, and move, and have our being" in an atmosphere of poison. What prudent man, having knowledge of the fact, would have arsenic or any other poison "laying loose" about his home, yet it is an every-day occurrence that he is paying men for spreading over his house and its surroundings this very thing. The very walls of his house are covered over with paper, into the color of which poison enters largely. Perhaps he congratulates himself on having found some green paper for his window-shades that will not fade; but how nervous it would make him, if he knew he was exposing the life of his darling babe, in case that it got some of that paper into its mouth, as children are apt to do.

Another folly of which too many are guilty is that, in procuring a mechanic who is to apply paint to any kind of work, the one who has mastered a knowledge of the composition of the paints used, if he asks a remunerative price for his skill and knowledge, is set aside for the one that has little or no knowledge on the subject, because he offers to work cheaper than the man of knowledge. These poisonous paints, in skillful hands, are indispensably useful. For instance, in painting the bottom of a ship, verdigris, or some similar poisonous paint, should be used. Insects that live in water, and which would otherwise attach themselves to the bottom of the ship, on account of the poisonous nature of the paint are kept off, and the bottom does not need cleaning as frequently as it otherwise would. This would be a more useful and safe way of using poison than decorating sugar-toys with it for children to eat. But it is lamentable to say that many who are entrusted with the use of paints do not know the difference.

The Prussian blue that is mixed with chrome yellow in making chrome green, is not a deadly poison; but the chrome yellow, where it is made of lead, is; and this will be found the most harmless of any kind of green paint, no matter what name it may have assumed. In carriage-painting, the paint is generally protected by a coat of varnish, and it is seldom that any inconvenience arises from its use after it is once put on; but the painter should be careful about inhaling it when dry, or while mixing.

Black paint is generally a carbon of some vegetable matter, and, as has been said, will resist the action of the atmosphere longer than any other paint. It is not classed among the poisonous paints. There are many varieties of this paint. The common lamp-black is the soot of resinous vegetables after burning the same. It is a useful paint, not only when used alone, but for tinting other

paints. The various kinds of this paint have assumed various names at different times, generally derived from the article that was burnt to make the black, such as ivory-black, peach-stone-black, vine-black, &c. Drop black seems to have taken its name from the appearance of it, being filtered or ground when in a semi-liquid state, and which by dropping forms itself into conical-shaped masses. All the last mentioned varieties have a preference over lamp-black so far as regards color; they being a deeper and clearer tint of black. None of the black paints that are carbons have any drying quality on linseed-oil, yet, when the oil is prepared with some other dryer and mixed with black it will dry quicker than the same oil will with white paints. The reason of this it is well to understand, for it will help us materially in applying colors to their proper places. Black absorbs heat, white reflects it back, therefore, the color that will absorb heat, having equal dryer mixed with the oil, will dry the quickest.

All dark colored paints partake more or less of this quality of absorbing heat in proportion to their darkness. We often see a covering over a coach, rail-road car, deck of a steamboat, &c., which is expected to exclude the rays of the sun as well as rain, painted a dark color. The consequence is, that the heat is absorbed by the covering to such a degree that but very little heat is excluded by the covering. On the other hand, if a pure white was used the heat would be excluded by its reflection, and the desired object would be attained. White clothing, on the same principle, is warmer in cool weather and cooler in warm weather. The same law of reflection affects carriages to a considerable extent,—a dark color is subjected to a greater degree of heat than a light colored one, consequently more liable to shrinkage. In using black paint these conditions should be well weighed, and a true balance struck between its usefulness and beauty. Here we may observe that white houses are more comfortable in hot weather than dark colored ones, on account of the coolness.

Sometimes we see dark colored carriages, when exposed to the sun, blister, and it is very unsafe to expose a newly painted black carriage to the steady rays of a hot sun. The heat will become so intense that we cannot hold our hands on the black paint for any length of time. We have noticed this effect on wooden ships. The black that was spread over a seam that was pitched would become so hot that the pitch would melt and run out, leaving the caulking exposed to wet, which would absorb water and rot out in a short time. Hence sailors learned to say that black rotted the ship. All the effect that it had, either in rotting or preserving the ship, was, that it excluded the water and atmosphere. The painter who expects to excel, should be familiar with these facts, for they surely find an opportunity to use their judgment on this subject.

Prussian blue is a prussiate of iron. It is manufactured from old leather, blood, and other things that contain iron. Prussic acid, in combination with iron, forms this blue. This paint, when used alone, makes a handsome blue-black, which, for intensity of color, exceeds any black that we have, besides being a good paint to polish over. Mixed with white it forms every shade of blue that may be desired. It does not hold its color as well as some other paints of the blue shade.

The modern ultramarine-blue takes its name from the

ultramarine-blue so highly prized by the ancients. Like the ancient ultramarine, it is extremely lasting in its color. The process of making, or what it is made of, we are unacquainted with, or whether it is poisonous or not. The ancient ultramarine was made of the Lapis Lazuli stone, and was more precious, ten times over, than gold. The paint that has taken its name is a beautiful blue; but it is so transparent that when used on carriages it should be over Prussian blue, toned down to the same color with white paint.

(To be continued.)

## Trimming Room.

### OBSERVATION ON THE PRESENT STYLE OF TRIMMINGS.

NOTWITHSTANDING our national troubles, we can see no abatement in the popular desire for maintaining and keeping-up appearances. The moneyed aristocracy have lavished their funds as freely as ever, or, if anything, a little more liberally, and, the past season, bought the finest and most costly vehicles ever before built in America. Prices have ruled twenty-five per cent. higher than last year, and sales have been double in number. The call for costly trimmings has increased unprecedentedly, and, to a casual observer, it would appear as though we were running to ruin! So far from it, however, is the fact, that nobody fails, and the country never seemed to be in as good circumstances financially, nor at any time so hopeful of a triumph over its enemies, either domestic or foreign, as now.

For the heavier kinds of carriages Cotelines of various colors—brown, red, blue, &c.—still maintain their popularity, although costing as high as \$5.50 per yard. At one time it was thought that Terry would take its place to a great extent, but the high price it commands, without exhibiting a corresponding show of richness when put into a carriage, seems to operate against its use for that purpose. Silk is still used to some extent, but is not as durable as coteline. It takes about 14 yards of coteline to trim a coach, and about 10½ for a coupé. For many jobs an article between coteline and damask is found very serviceable, called Pekin cloth. It is furnished of various colors, at about \$2.50 per yard, and is so good a representative of coteline as to be scarcely distinguishable from it at a little distance off. For the head linings of buggies it supplies a pretty article to take the place of damask.

Cloth still continues to be used for the linings of summer rockaways and all light vehicles, laces of every kind having been discarded altogether. For the cushion straps, instead of the expensive and clumsy leather one, a fine kind of worsted webbing, costing 42 cents, furnishes a neat substitute, and looks nicer in contrast with the cloth linings. It is a rare thing to find silk sun-curtains in city-made work. The festoon fringe takes its place, universally, in the best work.

Leather for linings are only used for vehicles, or that portion of them, entirely exposed to the weather, such as the dickey-seat, &c. The fancy, gew-gaw style of trimming got up for the southern trade a few years ago has dropped with their orders, and we trust that for the credit and honor of the craft it will not again be in vogue. In this connection we may observe, that we find in a foreign periodical a notice of a new mode of tanning hides and

skins, which may possibly have some influence, hereafter, on the carriage business.

The inventor is M. Henry, of Fleet street, London. Before the hides are curried he treats them with chondine, glutine, or other proteic and gelatinous matters, or with substances congeneric thereto employed by preference, in combination with neutral salts, or with zinc, to make them thicker, stronger, and more durable, and to improve their qualities generally. A composition for this invention is provided by coating gelatine, glycerine, and animal albumen with a neutral salt, or one of the oxyds before mentioned.

A word about stitching plates. In our recent travels we find some localities where such would be acceptable, but they are so limited that we think our usual plate devoted to the purpose can be more usefully filled with something else. We shall, therefore, for the present omit them.

---

## Editor's Work-bench.

---

### VISIT TO CANADA.

(Concluded from page 60.)

A HASTY visit to Brantford, and then we returned and spent our first Saturday and Sabbath at St. Catharine's, with our kind friend Robert McKinley, Esq. This gentleman more than once has shown himself a true friend of the *Magazine*. A ride of several miles in his company took us to his bending works, the motive-power of which is drawn from the Welland Canal, a noble work, completing ship navigation between Lakes Erie and Ontario. To us it was a novel sight to find at all hours steamers, ships, &c., passing and repassing among hamlets and forests, often nothing observable above surrounding objects but the masts and rigging. Mr. McKinley is prepared to furnish the trade with spokes, bent-stuffs, seat spindles, &c., from timber of the first quality, "in lots to suit purchasers"—much of which he obtains from the States. We were shown hickory, ash, and oak of Canadian growth which, in appearance, surpassed anything we had imagined it possible to find there. Our friends, of course, will find it their interest to patronize these "home productions." There is one fact about a Canadian Sabbath worthy of imitation among us: it is, outwardly at least, observed as a day of rest—a holy day.

Early on Monday morning, *armed* with numerous introductory letters, we bade adieu to our friend and his good lady, and journeyed on to Galt; but no business could be done. Galt and his wife were engaged in celebrating Her Majesty's Birthday—the fourth of July for the Canadians—and honored with many proceedings quite as boyish as with us on our anniversary: a juvenile entertainment and horse-racing in the forenoon; in the afternoon boat-racing, games, and sports of various kinds, closing with a torch-light procession in the evening. We saw a man stand and jump 11 feet; and a "darkey" bar-

ber of the place astonished the "white trash" by a running hop, step, and jump of 38 feet 10 inches. A sack race of 400 yards ended the sports, and amused us not a little. But the crowning exhibition of all was the display made by Sir John Falstaff and his recruits, which threw everything in that line ever got up in New York quite into the shade. We have space for only a condensed account.

Soon after five o'clock P.M. an *avant courier*, in the character of an Indian warrior, with a train of followers, made his appearance, succeeded by "Gideon's Band from Africa," in the most grotesque and comical-looking car ever "improvised" by a company of carriage-makers in any country. We suspect this "piece of architecture" had its origin in the shop of our friend Davidson, of the "Victoria Works," as we saw it, stripped of its *outward adornings*, in his yard on the following day. An artillery company came next, with an awning-post for their Whitworth, bestrode by artillerists in variegated costumes; then Falstaff's recruits, armed *contrary* to law; a colored gentleman and his Dinah, a lovely couple, in a dilapidated carriage, begging description; a couple of "jintlemen" from Donnybrook, in a *sulky*, looking sulky "enough to make a horse laugh;" a barber and his assistants, Ethiopian serenaders, devils, and other equally interesting characters. But our brother of the *Dumfries Reformer* must tell the remainder of the story:

"The whole company presented such a motley, ridiculous, heterogeneous mass of colors and absurdities, and the actions, gestures, and various performances of the different characters and groups were so amusing, that the faintest idea could not be given of the proceedings. Lieut.-Gen. Falstaff and his recruits, fatigued from their long march, sat down to a bountiful repast of raw turnips, and, after being refreshed, went through their military exercises, to the call of a three-penny trumpet. Their commander gave the calls, and surveyed their movements through an opera glass formed of two black bottles, ever and anon flourishing his sword—a hand-saw—in burlesque imitation of a heroic leader. All at once the band struck up a lively air, and commander and recruits for the time forgot their high occupation and engaged in a general hoe-down. In another quarter the barber and his assistants were plying their avocation very industriously, with razors and scissors of Brobdignagian proportions, and a comb which had evidently done duty as the head of a rake. The natives from Donnybrook—"a broth of a boy" and two Biddies in character—engaged in a lively jig; and the Ethiopians had vocal and instrumental music and dancing. The artillery company went through their exercises, but seemed more proficient in *priming* than loading. The other characters were amusing the crowd by displaying their grotesque dresses and going through laughable antics, and the whole was enlivened by the hideous discord made by the Band. After remaining for about half an hour on the Square, the company took their departure."

The day following (May 26), through the kind offices of Mr. Thos. Todd, the gentlemanly foreman of the Vic-



toria Works, and others, we obtained, in one half day, subscriptions amounting to over \$50. Mr. E. Holmes will also please accept our thanks for attentions shown in furtherance of our mission, on this occasion.

Having visited some intermediate places, we afterwards found ourselves in London, a very pretty city, terminating our journey westward. We noticed here, as elsewhere in Canada, that the early hours of the morning are not disturbed by the bustle and hum of business, as among us. They take matters there more in the English fashion—very leisurely. We had the pleasure of making the acquaintance here of Messrs. H. and J. McBride (one member of which firm is a candidate for Parliament), Mr. McKellar, Mr. Dart, and others. To the credit of the craft, we found among its members, in Canada, several mayors of towns, &c., from which we infer that the carriage-makers occupy an important place in the ranks of society. The work made in London is very creditable to the craft.

On leaving for Stratford, by the Grand Trunk Railway, we had a trick played on us, which outdoes anything charged to Yankeedom. The fare is one dollar, for which we offered a two-dollar Canadian bill. Instead of handing us change in kind, as we had a right to demand, we were put off with silver, because the tricky ticket vender—or his masters—could get forty cents premium on the paper by selling it. A remonstrance from us against this dishonesty brought no redress, so we had to pocket this peculating wrong as best we might. We could have got over the matter with better grace had we not found the Grand Trunk—the Grand Humbug, more properly—exorbitant in their charges to way passengers, such as our business made us, and their “first-class” cars dirty and uncomfortable, particularly on the western division of the line.

At Guelph, further eastward, we found three shops, at one of which we made the acquaintance of Mr. Robert Scott, a worthy Scotchman, disposed to avail himself of every help for the advancement of his mechanical interests. Stepping into the shop of one “Savage,” on business, our republican ears were treated to a lecture on the beauties of a monarchical form of government over ours, as bringing more peace and happiness to its subjects; but “we could not see it,” and so told him rather decidedly. We need not tell the reader that he was an English gentleman; but in our opinion appropriately named. On the journey from Guelph to Toronto we unfortunately aroused the anger of another Englishman, the conductor, by impertinently asking, as a question, why the people did not paint their houses more in that part of the country, as the Yankees do. The answer came, “We do not issue as many shinplasters as you do.” Of course *that satisfied us*.

At the station in Toronto we found a clamorous set

of jehus, and an antiquated assortment of coaches, that claimed our coach-maker inspection, and gave us unfavorable impressions of the trade in the place. It is due, however, to mechanical genius in that city to state that, at the best shop—that of Mr. C. F. Hall—we saw carriages of different patterns, seldom equaled, either in originality of design or mechanical finish, anywhere,—of which we hope to give our readers proof hereafter. The proprietor of this establishment, and his accomplished foreman, Mr. David Ford, could not have shown us greater kindnesses had we been, instead of a stranger, an own brother. They warmly entered into the interests of our enterprise, and swelled our subscription lists considerably.

Calling a carriage, Mr. Hall took us to the Normal School Buildings, and other places of interest. The busts, statuary, and paintings alone in the edifice would well repay our readers for a visit to the place. The public grounds in Toronto are creditable to the city, and well laid out. In a park of about one hundred acres, the access to which is through a long avenue, macadamized and beautified by rows of horse-chestnut trees, in bloom at the time of our visit, we found laid the foundation for a monument to the Queen. On two sides in front are two trophies of the Crimean war; the following inscriptions explain, on the right-hand side: *Victoria Regina e spoliis, quæ Britanni Gallique conjuncti Sebastoli expugnati victores ceperunt Torontonensibus, D. D., A. D. MDCCCLIX.* On the left: “Taken at the capture of Sebastopol, by the allied armies of Great Britain and France, and presented by Queen Victoria to the citizens of Toronto. A. D. MDCCCLIX.” There are many objects of interest about Toronto which will well repay the tourist to inspect. The country east of Toronto is well cultivated, and has much the appearance of the lands in our New England states. But we must be brief, since our story is already too long.

A flying visit to Whitby, Oshawa, Bellville, Nappanee, and Kingston—the latter place sadly in need of a carriage-maker with a little enterprise—and we made our way home, *via* Cape Vincent, after an absence of twenty-two days. A few general remarks must suffice.

Thanking our numerous friends in Canada for their marked attentions to us personally—among these we include many our space forbids naming—we hope to revisit them at a future time under more prosperous circumstances; for we cannot disguise the fact that the American rebellion is ruining the business prospects of Upper Canada. With fifty per cent. discount made on his “greenbacks,” no American will venture there to trade a second time while this state of things exist; and as Canadian interests are promoted by trading with us, she must consequently suffer seriously while our war continues. That the people feel it to be so is painfully evident in the ste-

reotyped question, everywhere put to us in our journey, "When will this war end?" This question, more natural than reasonable, of course could not be satisfactorily answered. Our humor sometimes led us to exhibit our patriotism in a questionable shape, and punish their sensitiveness about the Trent affair, by assuring them that "we should dedicate fifty years to subduing the rebels, and go on making money, while they would be starving." This encouragement, of course, was intended particularly for the English element. We like the native Canadians; they are a noble class of people, generous and kind, to whom we shall always extend a friendly hand and a welcome interview when visiting our office.

#### SHIFTING-RAILS ONCE MORE.

MANY correspondents have written us in relation to the shifting-top rail patented by Harmon Hibbard in July, 1851, stating that damages are still claimed for infringements upon it. Four years ago (see Vol. II. of this Magazine) we *ventilated* the whole subject by giving the specifications of the patent with drawings, a full report of the meeting of carriage-makers in New Haven, Conn., with several letters from the craft in various parts of the country, and editorials, all going to show previous use,—as early as 1844. We have not space to go over the whole ground again, did we feel inclined, nor time to answer all the letters with which we are burthened; we therefore simply say, that those who are interested can learn all about the matter by mailing us \$4, for Volume II., bound, which will be sent by return post.

In connection with the above we publish two letters, and would, in conclusion, inquire of Mr. R. H. Sargent, what is *his* object in querying us? We can't imagine. Perhaps some of our readers may, by "putting this and that together."

CHICAGO, ILL., June 15th, 1863.

E. M. STRATTON, Esq.—*Dear Sir*:— \* \* \* I will take it very kindly, if you know anything about any patent for removable tops, if you would write me about them. There is a Ramson H. Sargent, who claims to be the assignee of a Patent for removable carriage-tops dated 1851, and is trying to get damages for infringements of said Patent. He claims the rail round the seat like the following: [In the letter is a diagram showing that S. claimed damages on the common rail of 1844, altogether different from Seymour's diagrams accompanying his patent, as given in Volume II., of this work.] Now, if you know anything of this matter, please inform me, and I will be greatly obliged for your kindness. I do not wish to be duped in the matter, and will rely on your information. Yours truly,  
T. H. B.

CONNEAUTVILLE, PA, July 29, 1863.

MR. E. M. STRATTON—*Dear Sir*:—Lewis Seymour, of Auburn, N. Y., has a patent granted to H. Hibbard in July, 1851, for shifting tops on carriages. His agent is now traveling through the county collecting infringements on *all* shifting tops. His patent provides for fasten-

ing the tops to the bottom of the seat by portable bearers, while those that are now made are fastened to the arms of the seat, and the bearers are made permanent, to which the rail is fastened by nuts. Will you have the kindness to inform me whether there was any kind of shifting tops made prior to July, 1851. An immediate answer will greatly oblige, yours truly,

R. H. SARGENT.

We repeat, What can be Mr. Sargent's motive in querying us, if, as our Chicago correspondent says, he himself claims to be the assignee? Who knows?

#### EDITORIAL CHIPS AND SHAVINGS.

RIOTERS AND THE CRAFT.—During the four days of terror, beginning July 14, among other classes of manufacturers, the carriage-makers came in for their share of troubles. Nearly all the shops in this city were visited (ours by some unaccountable circumstance they slighted) by some scoundrel, and the proprietors told that unless the hands were discharged and the doors closed they would be burned out. We are sorry to say that generally this threat was cowardly complied with. We say cowardly, for many, by arming their men might have bid defiance to such "people" as the mob was made up of. But we are glad to find one exception. Instead of being put down, in repeated threats, our friend, Mr. John Stephenson, put his premises "on a war footing," and prepared to give all hostile visitors a *warm salute*. As might be expected, the cowards gave 47 East 27th street the "go-by." Two wheelwright shops were destroyed in different parts of the city. May we never witness such scenes again.

LINSEED OIL.—The high prices charged for linseed oil, the past season, ought to encourage our farmers to cultivate flax. It is said that 14 bushels to the acre may be produced, and the seed has sold lately as high as \$3.50.

LARGEST CARRIAGE-FACTORY IN THE WORLD.—The largest carriage-factory in existence is said to be that of a Berlin (Prussian) company, formed for supplying railways with cars. Last year it employed 1,552 men, and made sales to the amount of \$1,350,000. It delivered 290 railway passenger carriages; 993 goods wagons, and 187 post, military and other carriages.

THE VALUE OF ENGLISH CARRIAGES IN AMERICA.—Our public journals lately contained the following advertisement: "A handsome and fashionable newly imported English carriage for sale—cost to import £500 sterling. May be seen at 45 East Fifteenth street. For terms apply to E. R. Crouch, 75 New Canal street." All the satisfaction we got on inquiring why the owner wished to sell it was, that "he was not able to keep it." He therefore offered it for \$400. Quite a discount to be made on "a handsome and fashionable newly imported English carriage," and not very encouraging for the next importer! We sympathize with the "importer," and therefore advise others to engage in some better business—until the rebellion is put down and horse feed gets cheaper.

MRS. GOV. YATES' PHAETON.—The citizens of Chicago have recently presented the wife of the Governor of Illinois with a splendid six-seated phaeton, costing nearly \$1,000, and added a fine span of horses at a cost of \$1,500, with harness to match. They did this as evidence that

they appreciated the patriotism of the Governor, as shown in his conduct since the rebellion broke out.

**CARRIAGE-BUILDERS' ART JOURNAL.**—This publication of great promises and small performances "fizzled out," in December, 1862, nearly a year ago. We do not wonder at this at all. The second publisher was less honest than the first. Under a promise—at his solicitation—of his furnishing a set of the Journal for a set of our Magazine, we forwarded to our agent in London, as requested, two years ago, the books, which he took, and has, up to this time, steadily refused to pay for—thus branding himself a dishonest man. Such men cannot and ought not to prosper. We have very little doubt that he thought it a pretty trick "to come it" over a Yankee. Perhaps it was; but we think that it cannot be done again in the same way.

**FAIR OF THE AMERICAN INSTITUTE.**—This year the Fair will be held in the Academy of Music, directly opposite our office, commencing September 2d. Those who may visit the Fair are invited to make us a call.

**A LONG STAGE ROUTE.**—The stage route between Atchison in Kansas and Placerville in California is believed to be the longest in the world, being 1,915 miles. The fare is two hundred dollars—ten and a half cents per mile.

**ANCIENT ANVIL.**—The father of Gen. Green, of Revolutionary fame, was a blacksmith. The anvil he used is still shown to the visitor by his family, who still occupy the old homestead at East Greenwich, Rhode Island.

#### LITERARY NOTICES.

*The First Year of the War*—a Southern history by a Southern author—has recently been republished by our friend, C. B. Richardson, 594 Broadway, in cloth, at \$2 per vol. As might be expected, it is a one-sided story, full of charges of wrongs committed by the Northern people against the South. To swallow the story as told by the Southern historian, will require a strong dose of *Copperheadism*, but to those who are anxious to *andi alteram partem*, the volume will prove highly interesting. Truth never suffers from interchange of thought. We understand that the work has had a large sale, and is amply remunerating the enterprising publisher.

*The New England Hist. and Genealogical Register*, for July, lies before us. This work, published quarterly by Mr. J. Munsell, 78 State street, Albany, at the low rate of \$2 for 400 pages, with several portraits, is one of the most "useful books to have in the house" we have seen in a long time. We would like to find that every New Englander was taking it. Try it for one year at least, and see what a treat it will afford you.

*The Atlantic Monthly* seems to improve in interest and value with every issue. It is judiciously edited, neatly printed, and is one of those periodicals one is not obliged to get bound before he may place it in the library—it is folded in a stiff cover, and lettered to hand. The August number has a variety of interesting articles, among which are, An American in the House of Lords, Debby's Debut, Wet-weather Work, The Geological Middle Age, Side glances at Harvard Class-day, &c. Ticknor & Fields, pub., Boston.

#### AMERICAN PATENTED INVENTIONS.

March 10.—**IMPROVED WAGON BODY.**—N. B. Cooper, Gratis, O.: I claim the ends of the wagon body as herein fully set forth and described, in combination with the frame D, and the side pieces H and O, as and for the purpose specified.

**IMPROVED BENDING AND SETTING TIRE.**—J. C. Singer, Ebensburg, Pa.: I claim the arrangement and combination of the rack plates B, the movable upright I, the fluted roller J, the portable rollers E, with movable collars G, as operated by gear wheels M and N, and gaged by figures as described, and for the purposes herein set forth.

**IMPROVED WRENCH.**—G. H. Griswold, Logansport, Ind.: I claim making the notches or openings of a bar wrench of two sizes or capacities, so that, by turning it over, it will present different areas of openings, substantially as herein represented.

17.—**IMPROVED CARRIAGE JACK.**—George L. Cummings, of New York city: I claim the combination of the eccentric lever C, with the upright slide-rest D, by which the power to raise the axle is obtained, substantially as described and set forth as above.

**IMPROVED RING FOR MARTINGALES.**—W. M., of New York city, assignor to S. C. Welling, of New Rochelle, N. Y.: I claim the ring for martingales, &c., manufactured as set forth, with a metal ring enveloped in composition, as and for the purposes specified.

24.—**INSTRUMENT FOR TRIMMING OR CUTTING BOLTS.**—Hiram Beckwith, Grass Lake, Mich.: I claim the bars A C, provided with the semi-circular recesses *e e*, and cutters G G, in combination with the link B, cam D, and lever E, all constructed and arranged as shown, to form a new and improved implement for the purpose specified. [This instrument is designed especially for trimming off the ends of carriage bolts close to the nuts.]

**IMPROVED WAGON FOR TRANSPORTING MEDICINES.**—Jacob Dunton, Philadelphia, Pa.: I claim the subdivision of the body of a wagon or cart into a number of packages or compartments, so constructed and arranged that they will adapt themselves to the twisting and lurching of the wagon, preserve their contents from injury, and be capable of convenient transportation on the backs of animals, substantially as set forth.

31.—**IMPROVED FURNACE FOR HEATING TIRES.**—Oliver M. Brown, of Toledo, Ohio: I claim the above described furnace as a new article of manufacture, the same being provided with a peculiar arrangement of flues with doors, in the manner and for the purposes set forth.

April 7.—**IMPROVED MODE OF MANUFACTURING NUTS, BOLTS, &c.**—John Marsden, of Orrell, England: I claim, *First*, The making, forging, and punching nuts and washers, without waste of metal, from round, rod or bar iron, or other metal, by the combination of mechanical parts, put together and working essentially as herein before described and shown. *Second*, I claim the making of bolts or spikes, by and with the combination of mechanical parts, the modification herein directed being previously made, put together and working essentially as hereinbefore described.

**IMPROVED HARNESS SADDLE-TREE.**—John Fonda, of Albany, N. Y.: I claim forming an elevated recess *a*, above the arch of the front bow, and attaching the cantle piece in a socket or cavity behind the bolt hole of the front bow above said elevated recess, substantially as and for the purpose herein specified.

## CURRENT PRICES FOR CARRIAGE MATERIALS.

NEW YORK, August 14th, 1863.

Apron hooks and rings, per gross, \$1.25.  
 Axle-clips, according to length, per dozen, 50c., 63c., and 75c.  
 Axles, plain taper, from  $\frac{1}{4}$  to 1 in., \$5;  $1\frac{1}{2}$  in., \$6;  $1\frac{1}{4}$  in., \$6.50.  
 Swelled taper, 1 in. and under, \$5.25;  $1\frac{1}{2}$  in., \$5.75;  $1\frac{3}{4}$  in., \$6.75;  
 $1\frac{1}{2}$  in., \$8.50;  $1\frac{1}{2}$  in., \$10.  
 These are a superior axle, and more frequently called for than any others.  
 Do. case-hardened, half-patent, \$7; do. \$8; do. \$8.50.  
 Bands, plated rim, under 3 in., \$1.75; over 3 in., \$2.  
 Do. Mail patent, \$2.50 a \$3.25.  
 Do. galvanized,  $3\frac{1}{2}$  in. and under, \$1; larger, \$1 a \$2.  
 Basket wood imitations, per foot, 88c.  
 When sent by express, \$2 for a lining board to a panel of 12 ft.  
 Bent poles, each \$1.  
 Do. rims, under  $1\frac{1}{2}$  in., \$2 per set; extra hickory, \$2.50.  
 Do. seat rails, 44c. each, or \$4.50 per doz.  
 Do. shafts, per pair, 75c.; bundles, \$4.50; extra, \$5.50.  
 Bows, per set, light, 75c.; heavy, \$1.12.  
 Bolts, Philadelphia, per gross, as per printed list.  
 Do. T, per 100, \$3 a \$3.50.  
 Do. tire, \$1.05 a \$1.80, according to size.  
 Buckram, per yard, 25c. a 35c.  
 Buckles, per gross, 88c. a \$1.25.  
 Burlap, per yard, 25c.  
 Buttons, japanned, per paper, 15c.; per large gross, \$1.50.  
 Carriage-parts, buggy, carved, \$4.  
 Carpets, Brussels, per yard, \$2; velvet, \$2.75; oil-cloth, 60c. a 80c.  
 Castings, malleable iron, per lb, 12c.  
 Clip-kingbolts, each, 30c.  
 Cloths, body, \$3.75 a \$4.50; lining, \$2.25 a \$3.25. (See *Enameled*.)  
 A Union cloth, made expressly for carriages, and warranted not to fade, can be furnished for \$2 a \$2.25 per yard.  
 Cord, seaming, per lb, 25c.; netting, per yard, 5c.  
 Cotelines, per yard, \$3.50 a \$5.  
 Curtain frames, per dozen, \$1 a \$1.50.  
 Do. rollers, each, 75c. a \$1.  
 Dashes, buggy, \$1.75.  
 Door-handles, stiff, 50c. a 63c.; coach drop, per pair, \$2 a \$3.50.  
 Drugget, felt, \$1.62.  
 Enameled cloth, 5 qrs., 65c.; 50 in., \$1.40.  
 Enameled linen duck, 4 qrs., 55c.; 5 qrs., 75c.; 52 in., 90c. Colored, 15c. higher per yard.  
 Felloe plates, wrought, per lb, all sizes, 15c.  
 Fifth-wheels wrought, \$1.25 a \$1.38.  
 Fringes, festoon, per piece, \$1.75; narrow, per yard, 15c.  
 For a buggy top two pieces are required, and sometimes three.  
 Do. silk bullion, per yard, 35c. a 75c.  
 Do. worsted bullion, 4 in. deep, 35c.  
 Do. worsted carpet, per yard, 6c. a 10c.  
 Frogs, 38c. per pair, or \$1.63 per dozen.  
 Glue, per lb, 25c.  
 Hair, picked, per lb, 50c.  
 Hub-borers (Dole's) for light work, \$15; heavy, \$18 a \$20.  
 Hubs, light, morticed, \$1; unmorticed, 75c.—coach, morticed, \$1.50  
 Japan, per gallon, \$4.50.  
 Knobs, English, \$1.75 a \$2.  
 Laces, broad, silk, per yard, 70c.; narrow,  $5\frac{1}{2}$ c.; silk, 8c. a 10c.  
 Do. broad, worsted, per yard, 31c. a  $37\frac{1}{2}$ c.  
 Lamps, coach, \$14 a 18.  
 Lazy-backs, \$9 per doz.  
 Leather, collar, dash, 25c.; slit do., 15c.; enameled top, 25c.; harness, per lb, 45c.; flap, per foot, 15c. a 20c.  
 Linen, heavy, a new article for roofs of coaches, 55c. a 70c. per yard.  
 Moquet,  $1\frac{1}{2}$  yards wide, per yard, \$5.  
 Moss, per bale, 10c.  
 Mouldings, plated, per foot, 12c. a 15c.; lead, door, per piece, 30c.  
 Nails, lining, silver, per paper, 6c.; ivory, per gross, 25c.  
 Name-plates.  
 See advertisement under this head on 3d page of cover.  
 Oils, boiled, per gallon, \$1.50.  
 Paints. We quote white lead, extra, \$3.50; Eng. pat. black, 25c.  
 Pekin cloth, per yard, \$2.  
 A very good article for inside coach linings.  
 Plushes, per yard, \$2.  
 Pole-crabs, silver, \$5 a \$6; tips, \$1.12.  
 Rubbing stone, per lb, 12c.

Sand paper, per ream, \$3.50.

Screws, gimlet.

Add to manufacturer's printed lists 20 per ct.

Do. ivory headed, per dozen, 38c. per gross, \$4.  
 Serims (for canvassing), 15c.  
 Seats, buggy, pieced rails, \$1.75; solid rails, \$2.50.  
 Shaft-jacks (M. S. & S.'s), light, \$2.60; heavy, \$2.87. a \$3.25.  
 Do. tips, extra plated, per pair, 31c.  
 Silk, curtain, per yard, \$1 a \$2.25.  
 Slat-irons, wrought, per pair, 55c.  
 Slides, ivory, white and black, per doz., \$6; bone, per doz., \$1.50;  
 No. 18, \$1.75 per doz.  
 Speaking tubes, each, \$4.50.  
 Spindles, seat, per 100, \$1.  
 Spring-bars, carved, per pair, \$1.  
 Springs, best temp. Swedes, per lb, 24c.; black, 17c.; bright, 18c.;  
 best tempered, 21c.  
 Two springs for a buggy weigh about 28 lbs. If both 4 plate, 34 to 40 lbs.  
 Spokes, buggy, per set, \$3, or about 5c. each for all under  $1\frac{1}{2}$  in.  
 For extra hickory the charges are  $6\frac{1}{2}$ c. each.  
 Steel, Farist & Co.'s Homogeneous American, per lb, 16c.  
 Do. English Homogeneous, do. 20c.  
 Do. Compound tire, do. 7c.  
 Stump-joints, per dozen, \$1.25 a \$1.50.  
 Tacks, 5c. and upwards per paper.  
 Tassels, holder, per pair, 63c. a \$1; inside, per dozen, \$3; acorn  
 trigger, per dozen, \$1.25 a \$1.50.  
 Terry, per yard, \$7.  
 Top-props, Thos. pat., per set, 35c.; plain, com., 35c.  
 The patent props, with silver-plated nuts, per set,  $87\frac{1}{2}$ c.

Tufts, ball, per gross, 50c.; common worsted, 12c. a 25c.  
 Thread, Marshall & Co.'s Machine, No. 432, \$2.40 per half lb; No.  
 532, \$2.75 do.; No. 632, \$3.50 do.  
 Turpentine, per gallon, \$4.  
 Twine, tufting, per ball, 35c.  
 Varnishes (Amer.), crown coach-body, \$5 a \$5.50; hard drying, \$5;  
 nonpareil, \$7.  
 Do. English, \$9 a \$9.58; or \$6.25 in gold, or equivalent.  
 Do. American imitation of English, \$7.  
 Webbing, per piece, 44c.  
 Whiffle-trees, coach, turned, each, 25c.; per dozen, \$2.50.  
 Whiffle-tree spring hooks, \$2 per doz.  
 Whip-sockets, rubber, per dozen, \$7 a \$9; pat. leather, stitched, \$3.  
 Window lifter plates, per dozen, \$1.50.  
 Yokes, pole, each, 75c. to \$1.25.  
 Yoke-tips, 50c. a 75c.

We intend to enlarge and correct this list monthly, so as to enable those who commission us to make their purchases to ascertain by computation about the amount they require to remit us. This should be done, if a large sum, by draft to our order in New York, or if small, in a registered letter to our address. None but cash orders filled, and where C. O. D. bills are forwarded with the goods by express, charges for collection must be added, which amount in ordinary cases to from 25c. to \$1, according to distances. All this may be saved by sending us the money with the order. Please read notice of "General Business Agency," on 3d page of the cover, in connection with the above.

## TO READERS AND CORRESPONDENTS.

BACK VOLUMES of this work will be sold, in numbers, for \$3; when bound, for \$3.50, to which, if sent by mail, 48 cents must be added to prepay postage; if two or more volumes are called for at one time, they can be had for \$3 each, or will be sent by express, at the purchasers' expense, at the same price. The subscription to the Fifth Volume, now in course of publication, will be (in consequence of the advance in paper and printing) four dollars, IN ADVANCE, for the twelve numbers; and these will be issued, in 1863 for Jan., March, May, July, Sept., Nov., Dec., and afterwards monthly until the close of the volume in May, 1864.

AGENCY.—Our friend Mr. Henry Harper, who is traveling in the West, is authorized to take subscriptions for us, and receipt for moneys paid; and any contract he enters into concerning this Magazine will be honorably carried out by the Publisher. In Canada West, Mr. Robert McKinley, at St. Catharines (dealer in carriage-hardware), will act as our local agent.



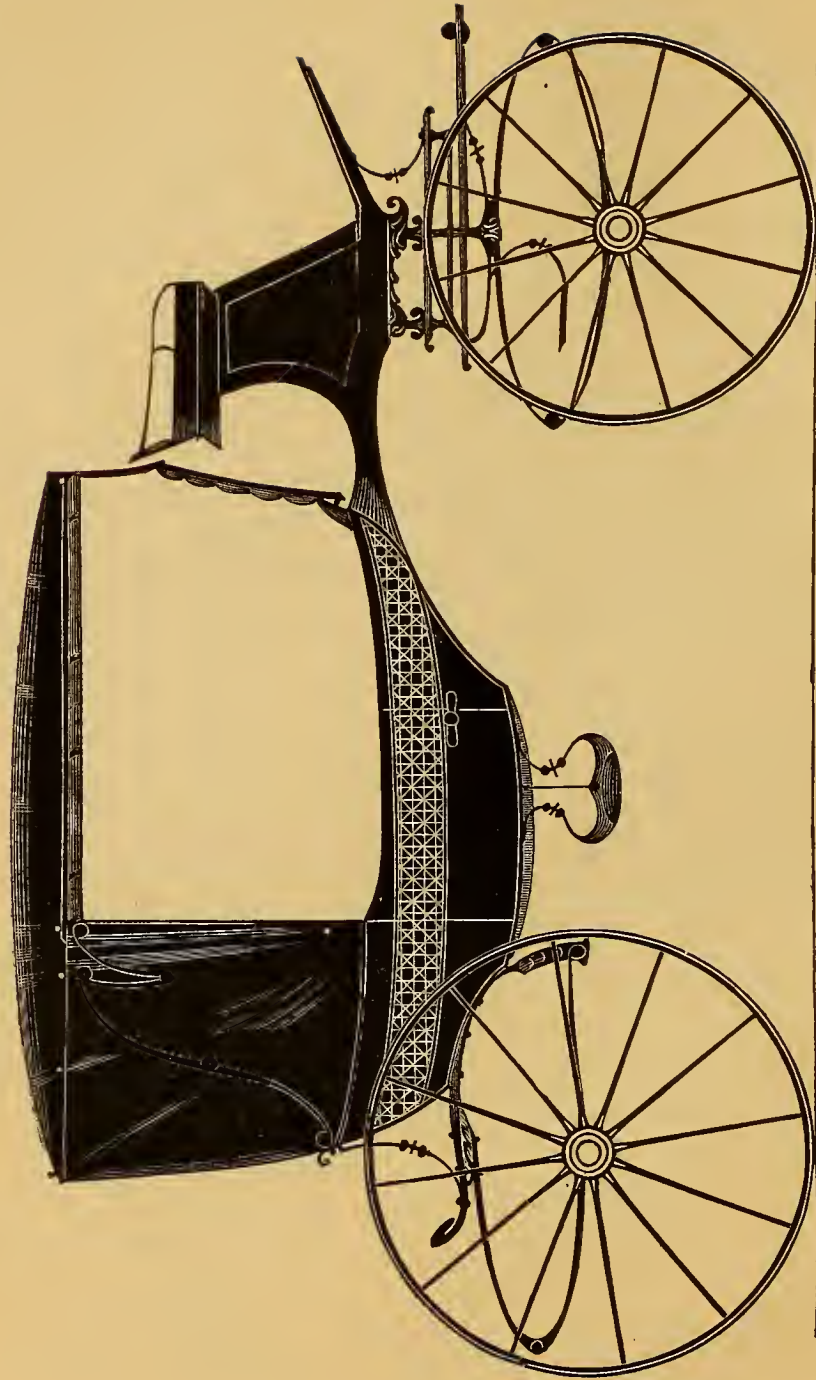

SOMERSET CALECHE.— $\frac{1}{2}$  IN. SCALE.  
*Designed expressly for the New York Coach-maker's Magazine.  
Explained on page 87.*

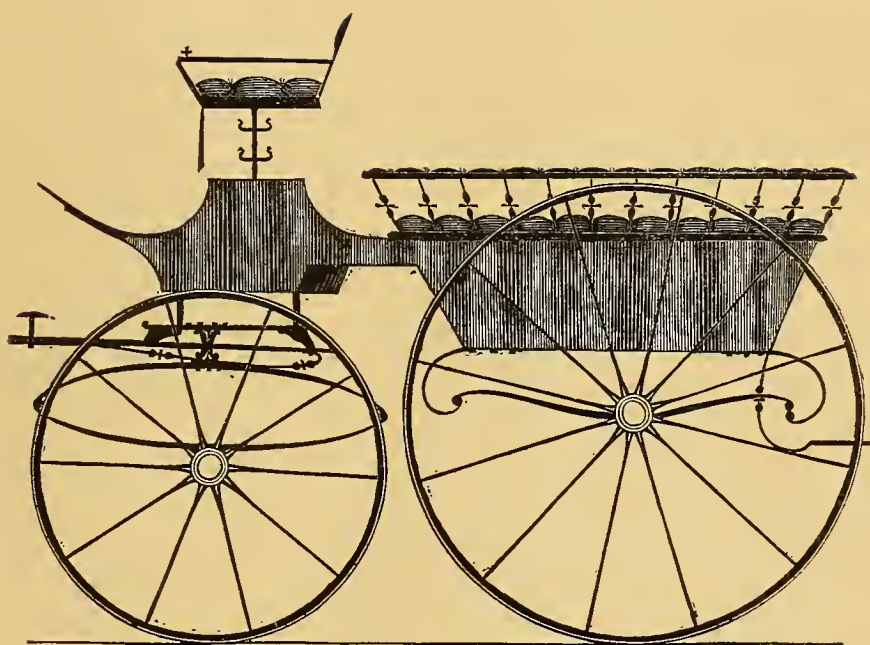

SPORTING PHAETON.— $\frac{1}{2}$  IN. SCALE.

*Designed expressly for the New York Coach-maker's Magazine.*

*Explained on page 87.*







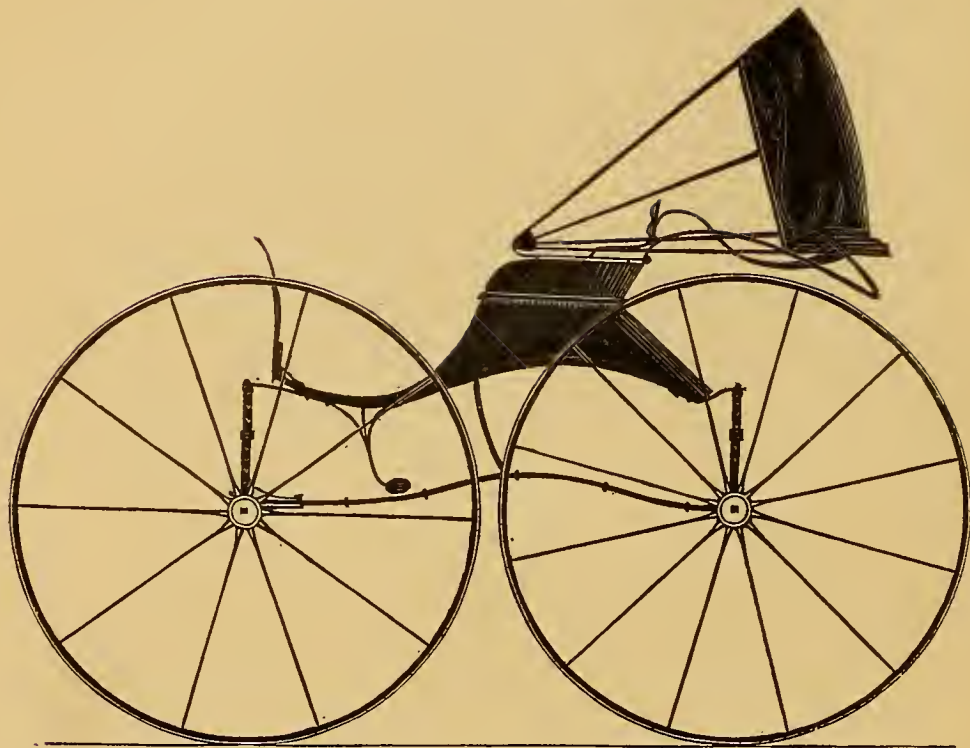

LINCOLN BUGGY.— $\frac{1}{2}$  IN. SCALE.

*Engraved expressly for the New York Coach-maker's Magazine.*

*Explained on page 87.*



No. 1.



No. 2.



No. 3.

ORNAMENTAL DESIGNS.

*Engraved expressly for the New York Coach-maker's Magazine.*

*Explained on page 89.*





DEVOTED TO THE LITERARY, SOCIAL, AND MECHANICAL INTERESTS OF THE CRAFT.

Vol. V.

NEW YORK, NOVEMBER, 1863.

No. 6.

## Mechanical Literature.

### THE TIREVILLE MISCELLANY;

BEING SELECTIONS FROM THE PRIVATE JOURNAL OF JOHN  
STILWAGEN, ESQ.

BY THE EDITOR.

(Continued from page 66.)

MANUFACTURERS are frequently put to expense and trouble, from the incompetence or mistakes of workmen employed by them; especially is it the case in an Art business, such as carriage-making, and where skill is in demand. An applicant comes to the shop for a job, representing himself to be a first-rate workman in some one of the departments into which our profession is subdivided, and he is forthwith set to work, under the supposition that *he* knows best what he can do, and that he will suit. The first week convinces us that we have been imposed upon, when perhaps a job is about one-half finished. The natural repugnance many workmen entertain against undertaking to complete what another has attempted induces the manufacturer to let the incompetent one continue on another week, in hopes that he may "get the hang of the shop," and show an improvement in the work undertaken. In most instances such experiments terminate in loss; either in the reputation of the shop, or in the pocket of the proprietor. An experienced mechanic will decide as to the mechanical *status* of a person as soon as he sees him handle tools; and a poor workman, in a shop where the manufacturer takes pride in getting up nice work, cannot be dismissed too soon. Such men may possibly get along with some detail, in a large factory of systematized labor; but for an indifferent hand, in a small shop, to go through with the entire job, is suicidal to all fair business prospects. Having suffered some in this respect, I have been induced to advise for the benefit of those who may come after me.

May 20. Sitting in my office this morning, pondering over my business prospects for the year, I was startled by the letter-carrier putting into my hands the following note:

PROSPECT HILL, May 17th, 18—.

JOHN STILWAGEN, ESQ: Dear Sir,—A complaint against you has

VOL. V.—11

been placed in our hands for damages, by Mr. Wm. Makeshift, for having infringed upon his patent shifting-rail. He claims damages \$150. An early call will save costs, and oblige,

Yours, respectfully,

GRABEM & SWINDLETHEM,  
Attorneys for Plaintiff.

Horrible! thought I; will these harpies, who go about preying upon the craft, never be *caged*? Must I forever exhaust my strength in order to earn a few dollars, and then hand over to some adventurer half my earnings, when he ought long ago to have been arrested for vagrancy, or put to hard labor in the State prison? Why, the "thing" has been in use, to my certain knowledge, at least ten years, and no one ever heard of this patent before. Surely, Job never suffered as we unfortunate carriage-makers do. But then he lived in an age anterior to the *legalization* of dishonesty, and before Patent offices were established. That probably makes some difference!

Smarting under the conviction that I was about to be made the victim of harpies, I sent Grabem & Swindlethem the following *polite* note:—

TIREVILLE, May 24th, 18—.

MESSRS. GRABEM & SWINDLETHEM: Gentlemen, I am in receipt of your letter of the 17th ultimo, threatening me with a law suit, unless I "come down" with \$150, the amount of damages claimed by your client, Makeshift, from me, through you. As I have never infringed on any reputed patent of his, I decline doing any such thing, at present. If it were not for a set of idlers, calling themselves inventors, backed up by another set of men denominated "pettifoggers," together studying how they may the more readily fleece honest mechanics, carriage-makers might live on the proceeds of their hard labor, and, perhaps, manage to make a decent show among their cotemporaries. However that may be, for my part, I have as much as I can do to pay my honest debts, at present, without encouraging a system of cheating in this community. You will, consequently, have to *make shift*, and obtain your bread out of some other person. Yours, &c.,

J. STILWAGEN.

June 10. Conversing with a friend from Courageville, this morning, I learn that he, too, has been threatened with a lawsuit by Makeshift several times, for an infringement on his nominal patent; but, as yet, it has only amounted to a threat. I therefore conclude that the letter from the lawyers of Prospect Hill is intended for a *scare*; but I am determined not to be frightened. [On page 12 of this volume we published the outlines of "A proposed Coach-maker's Protective Association," designed to meet just such a case as this of Stilwagen's, and

to put a stop to all illegal and improper claims made by dishonest adventurers, who, wolf-like, prowl around among the craft at the present time.] There are many cases where original inventions have been properly patented; these should be respected; but there are likewise many so-called *original* improvements no one is bound to respect, for they have been public property for many years, and in common use. Against this latter class I declaim. They have been the common source of "unnumbered woes" to almost every member of the craft engaged in manufacturing carriages in this country.

July 6. For the benefit of those who contemplate learning the "art and mystery" of carriage-making, I will here relate an instance in which *I* made money—out of pocket. It will serve to show the manner in which many of the craft *get rich*. An old customer, A, came to me, saying that he wanted a new carriage made; and, having described it, wanted to know my lowest figure for the same. Having ascertained this, he next wanted to know what I was willing to allow him for his old one. Here I was placed in a delicate situation. In the first place, having mentioned a certain price for the new carriage, expecting to be paid the money therefor, I could not well afterwards ask more, although that sum would scarcely reimburse me the expenses incurred in getting it up. In the second place, I found my customer set a higher value on old wagons of my manufacture, even, than I did myself, and much higher than I could ever bring the public to think them worth. One does not, under any circumstances, like to depreciate the value of his own productions, yet, in most cases, he cannot allow for them more than their commercial value, even in part exchange for a new one. Well, I had either to take the old wagon, at the customer's estimate of value, "or he would go somewhere else with his order." Of course I submitted; but the sequel will prove that there is some difference between one hundred dollars—*cash*, and one hundred dollars—*old wagon*. After laying out fifteen dollars in repairs, and spending several hours in chaffering with buyers, at the end of two months I succeeded in getting it off my hands at ninety dollars. As may be seen, *that* old wagon proved a profitable speculation—to *somebody*. This is a sample of the way in which many carriage-makers get—into the poor house, and is brought about by the inconsiderate and reckless mode of doing business competition induces some manufacturers to adopt, in order to get custom. The idea on the part of customers, that "if one won't, another will," and that other idea on the part of manufacturers, that, "if I do not take the man's order, somebody else will at his price," combined, has effected the ruin of thousands of business men, and will doubtless continue to do so for ages to come.

July 29. Having purchased a bale of moss, marked A, at what I considered a low figure, I was congratulating myself on having made a good bargain; but on opening the bale, I found it full of sticks and dirt, a very poor article of second quality. A closer inspection of the outside covering convinced me that the end of the original B canvass had been removed, and A substituted therefor, showing a fraud on the part of some parties through whose hands it had passed. Small business that, and yet I know of dealers, not far from Tireville, who are just *small enough* to engage in such mean business. In the end they will reap "bitter fruit" from such labors.

(To be continued.)

## A DECADE OF ENGLISH CARRIAGE-MAKING.

BY AN OBSERVER.

IN the Exhibition of 1851, the jury on carriages complained of a lack of variety, and feared that the trade was not fairly represented, and thought that a higher standard of merit might be claimed for English carriages than was there shown. They said that "while we recognize very generally the use of superior woods, leather, and other materials, in the construction of carriages, the most admirable workmanship, and a nice attention to details, we perceive many defects in style, and the display frequently of bad taste. There is often an injudicious expenditure of costly ornament and elaborate finish, which are incompatible with the serviceable class of carriages to which they are applied. In many instances this is carried to an extent that mars instead of enhancing the beauty of the vehicle, and, besides increasing the cost, is a positive detriment." This costly ornamentation and "gew-gaw" display sufficiently proved that a refined taste was yet lacking among many British carriage-builders. This same "defect in taste" was formerly exhibited in our carriages to gratify the fancy of Southern customers. It is a taste of the barbarian kind, which, we trust, will never again be seen in this country.

In the report of the Exhibition of 1862, we are told that "most of the English carriages show excellent workmanship and materials, some of them are also of elegant design, of well-proportioned construction, and finished with good taste as regards choice of colors and decoration; there are, however, some marked exceptions, chiefly as to the choice of colors and decoration, which the jury cannot but refer to as showing that there is room for improvement on this point." Although the carriages now made are lighter than formerly, our English friends have much to learn from us yet, in this respect. They have yet to learn that *quality* in material is far better than *bulk*, and that a clumsily-built carriage not only kills the animals drawing it, *but wears itself out*.

In the first Exhibition, 79 carriages were shown; in the last, 86. The difference in numbers was small, but the variety was evidently greater—proof that a new interest is awakened by these Exhibitions, and, as we doubt not, the result will be a greater improvement in building carriages the coming ten years. We trust that, before the time for another Exhibition rolls round, we shall be in a condition to show a greater variety in carriage-making ourselves, and hope to see the same class of work—American and English—side-by-side in honorable competition; for, after all, this is the only fair test of comparative merit. We would like the judges to have, for instance, two Victoria Phaetons—one from each nation—in contrast, believing that the liberality heretofore shown us, and the decidedly light and tasty work manufactured here, would bear away the prize, and increase respect for us and our productions in Europe.

EDITOR'S PORTRAIT.—Several subscribers have urged us to present them with our portrait. This we have until now declined to do, chiefly from delicacy. As we must, however, give one in each volume, and no other at present being available, we shall lay aside *our modesty* for once, and appear, as "natural as life," before our friends next month.

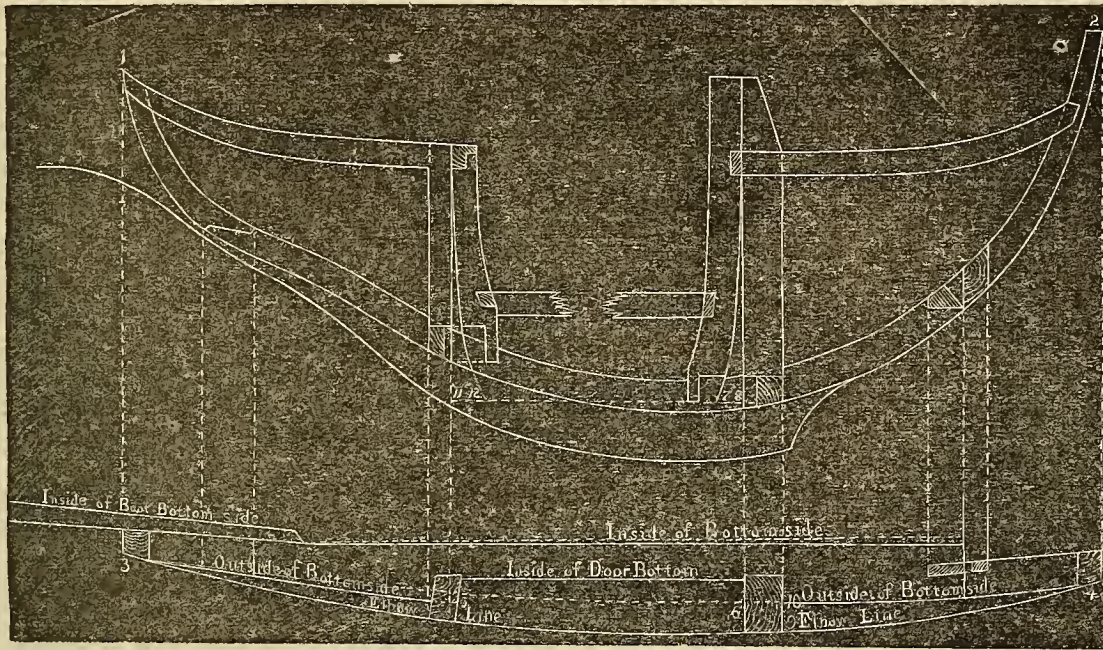
BAROUCHE, WITH A CANT-BOARD.— $\frac{1}{4}$  INCH SCALE.

## ENGLISH CARRIAGE ARCHITECTURE.—No. XIII.

BEGIN by laying the length of the body as seen in the dotted lines, on the cant-board. Next, draw the elbow lines as shown at the bottom from 3 to 4. Afterwards, the width of the door at 5 and 6. Then, the turn-under of the standing-pillar, shown at 7 and 8. This done, we next lay down the distance from the arm line, inwards (9 to 10), which must be the same as the turn-under of the standing-pillar at 7 and 8. Now draw a perfect sweep from 3, through 6, and continuing to 4. To get the proper turn-under of the front pillar, draw a parallel line, as shown on the body, at 8 to 11. Finally, lay down the same distance from 11 to 12, as shown from 7 to 8; this shows the distance the standing and front pillars require to be framed inwards from the arm-line.

## CARRIAGE-MAKING IN SAN FRANCISCO.

WE know of no branch of domestic manufacture that has, within so short a time, assumed, and is assuming, such increased proportions within our city as that of carriage-making. San Francisco already boasts several carriage shops, which, not only in their extent, but in the amount and character of the work they do, vie with those of the larger Eastern cities, where such work is made a specialty. In proof of this, one has but to pay a visit to either the extensive establishment of Henry Casebolt, or to that of George P. Kimball & Co., on Market street, or to any of the many other shops of smaller extent that abound in that and other neighborhoods. They are all full of business, many of their orders being for the replacement of vehicles destroyed by the unparalleled storms of the last winter. Kimball & Co. have just taken possession of a new two story brick building (built expressly for their use) near the corner of Market and Fourth streets. It has an iron front, a deep and extensive cellar, is 170 feet deep and 50 feet front, and extends through to Stevenson street. It is contemplated to extend its front still further. This addition will make it the largest carriage manufactory on the Pacific coast, if, indeed, it is not so now (the establishment of Mr. Casebolt competes with it here), and among the largest in the country. It is crowded with ve-

hicles of every description, from the light and diminutive sulky to the strong mountain coach—of home manufacture. But even yet it is found necessary to rely on the Atlantic cities for much of the materials of California-built vehicles, especially those parts designated as "trimmings." The necessity for importing such, however, is daily diminishing, and soon, doubtless, it will cease altogether, though Eastern wood will long, if not always, continue in demand. Most kinds of Eastern carriages can yet be sold in this market at a less price than those here made; but such will not long continue to be the case, as, among other reasons, the difference in the

rates of wages paid is constantly diminishing. This is not, perhaps, a matter for congratulation, but it is, nevertheless, a plain fact, made so by the governing law of supply and demand. The demand for home-built vehicles is just now very large. The orders are mostly from the interior, many come from Washoe, and not a few from Oregon and Washington Territory. The city demand, particularly for drays and trucks, is large. The number of light, fancy and family vehicles ordered, is an evidence of the social progress and permanency of our population; and that such can and are being made here, complete and thorough throughout, must be a source of gratification to all interested in the growth, not only of San Francisco, but of the entire State.—*San Francisco Daily Call.*

## ANCIENT ROMAN CARRIAGES.

BY THE EDITOR.

(Continued from page 67.)

ANOTHER very soft and comfortable carriage was called the *Pilentum*, and fashionable among all classes. It was a special favorite with the Roman ladies. Its light construction, when compared with other vehicles previously illustrated in these chapters, must have recommended it to general use. The name is said by some to have been derived from *pilens*, a hat, the *pilentum* often having a half-round top; and by others from *pila* (a pilaster), four of which supported the covering, as shown in our illustration on the next page.

According to Livy, 5, 25, as well as some other authors, this, the most popular of all Roman carriages, was a favorite with the matrons when they went to the temples to perform the sacred rights or mysteries of their religion. "*Honorem ob eam munificentiam ferunt matronis, habitum ut pilento ad sacre ludosque, carpento festo profestoque uterentur.*" The strictly classical character of our illustration is significant, and stamps it as being the result of much study on the part of its original designer. From a passage in Virgil (*in mollibus pilenti—*

in the easy Pilentina), some have inferred that the Pilentum was suspended on poles or straps, or some other contrivance, rendering them easy riding; but all such conjectures are merely speculations, unsupported by any

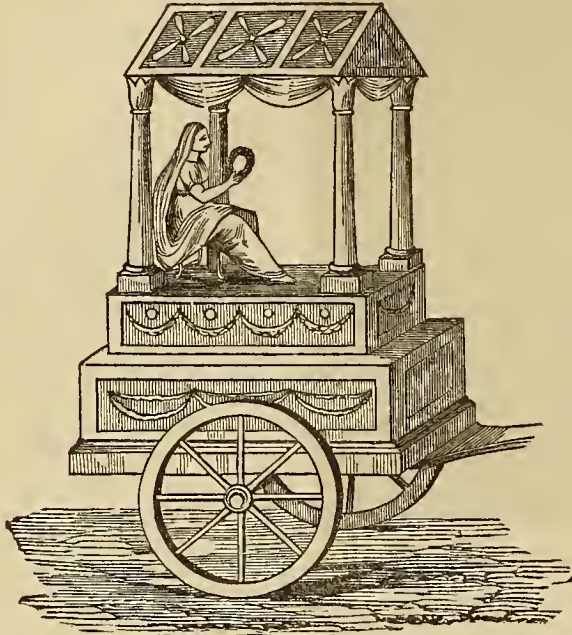

Fig. 5.

pictorial evidence descending down to our time. The roof was sometimes supported by long and slender pillars, the sides having only narrow festoon curtains, leaving them entirely open, so as to expose to view the occupants. The wheels appear to have been much lighter and higher than in other Roman vehicles; and this fact, in connection with their light and airy construction generally, is sufficient (by comparison) to entitle them to the qualification "easy"—particularly so to the draught animal.

We have before remarked that the ancient Romans had carriages adapted to different purposes. The Pilentum was well adapted for showing off the rich costumes of the matrons on public occasions, and for the exhibit of the votive offerings consecrated to the heathen deities, and, therefore, for a long time was the only vehicle allowed in religious processions—a particular mark of distinction from the Senate to those who had sacrificed their jewels and ornaments for the public weal. The Pilentum was frequently used to convey the vestals to the temple, for Prudentius says, "meanwhile, the celibate priestess, as in public pomps, rides in the Pilentum, blowing the sacred fire, and showing herself to the city." A passage in Macrobius confirms this opinion. The Pilentum seems to have been used extensively by all classes, in traveling great distances, their lightness, no doubt, contributing to this end.

We have evidence that the Pilentum was often made expensive and costly, the pillars supporting the top being rich in material as well as workmanship; in some instances, the cushions and other interior furniture being made from wool or silk, according to the purses of the owners. According to the authority of Servius, the body of these vehicles was generally painted a red color in his time; but earlier, sky-blue prevailed.

The Cisium was another, and supposed to have been a still lighter vehicle, on two wheels, and much used in transmitting the mails from one town to another; and its name

would seem to indicate speed—"Inde cisio celeriter ad urbem vectis."—Cic. Phil. 2, 31. The Pilentum was frequently termed "the covered Cisium," which it is supposed to have resembled in some respects. The drivers of the Cisium were called Cisiarii, who were often punished for fast driving and the ill-treatment of passengers—worthy prototypes of our modern Jehus.

The *Pegma* has been (we think), without sufficient authority, classed among Roman carriages. It was probably nothing more than an improvised triumphal car for public pageants. Pliny tells us that "*Caius princeps in circo Pegma duxit, in quo fuere argenti pondo cxxiii.*" A cotemporary, remarkable for its *diluted* literature, has run this *Pegma* "into the ground," under the serious impression that he was writing sober history.

The *Currus* or chariot, as among other cotemporary nations, was a very important vehicle with the Romans, but differing materially from the *Arma* of the Greeks. It does not appear to have been much used for warlike purposes in the Roman armies; in fact, they were held in contempt by the Roman soldiers, when these were sent against them by Mithridates in the battle of Thurium (see volume I., page 144, of this Magazine), even when armed with scythes. From a passage in Cæsar's Commentaries on his War in Gaul (B. IV., c. 33), we infer that war chariots were a novelty to his army, and Livy tells us that, on that occasion, "the enemy, mounted on chariots and cars, made towards them with such a terrible noise, from the tramping of the horses and the rolling of the wheels, as affrighted the horses of the Romans, unaccustomed to such operations.—See volume I., page 164, of this Magazine. In fact, a war chariot taken in Britain was afterwards exhibited, in a triumphal procession at Rome, as a great curiosity.

Although war chariots figured more often in the Latin poet's works than in the Roman armies, yet we must not conclude that they were unknown to the people of that nation. They were used in the Circus Maximus in celebrating the public games at different periods of the year. These chariot-races were divided into four factions—the *Prasina*, *Russata*, *Alba* or *Albata*, and the *Veneta*. The first, spring, was represented by green colors, summer by red, autumn by white, and winter by sky-blue. Green was the most taking color under the chief emperors. (Juv. Sat. 7, 193.) To these four, Domitian afterwards added golden and purple colors. To these chariots, not only horses, but mules, camels, and sometimes elephants, were hitched. The seventh time around the *metæ* generally decided a race.

"What charioteer would with the crown be graced,  
Ere his seventh wheel the mark has lightly grazed!"

According to Virgil, there were anciently twenty-four matches of chariots; four in each match, so as to make one hundred in all. *Centum quadrijugos agitabo ad flumina currus.* (Geor. 3, 18.) The last *missus* (course) was at the expense of the people, who made up a purse to defray the expense. This was called *Ærarius*.

Chariots filled very prominent places in the triumphal processions of the Romans. One lasting three days, given to Paulus Æmilius, in honor of his victories over Perseus, showed over two hundred and fifty chariots and a great number of wagons, carrying the spoils taken from the Macedonians in battle. The whole story is told by Plutarch, to which the reader is referred. In Kenneth's



Roman Antiquities may be found a plate of this pageant, where several varieties of Roman chariots are depicted.

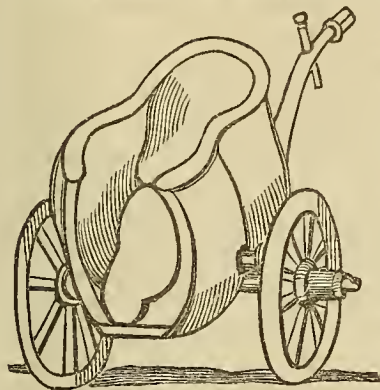

Fig. 6.

Chariots were distinguished as *sejuges*, *septemjuges*, *decemjuges*, &c., according to the number of horses drawing them. They seldom carried more than two persons, both standing, and were always drawn with the horses harnessed abreast.

We must add to the above a few observations regarding the construction of chariots. In ancient authors, the *antyx* or rail was

looked upon as a very important part of the body, and, therefore, it was taught that it should be made much thicker than the body to which it is attached. This, for greater security, was often supplied with plates of ivory, bronze, and sometimes the more precious metals. Among the Romans the axles are supposed to have been made of beach, ilex, ash, or elm. (Pliny's Nat. His. XVI., 84.)

An ancient chariot of excellent finish is preserved in the Vatican at Rome, from which it would seem that the axle was fastened to the body by nuts and bolts, as with us. Every circumstance warrants the conclusion that the wheel revolved round the axle arm as in modern times, and not fast to the axle turning with the wheel. The hub (*modius*) was made of some tough wood and banded with iron. In figure 6 this appears to have been extravagantly long. The spokes (*radii*) were six or eight in number; very rarely ten. The felloe or rim (*apsis*) was formed of four pieces, but whether bent or worked out by the Roman artist is an unsettled question, although most probably the latter. The tire (*canthus*) was put on in pieces or sections, in the "strake" form, when made of metal. This was undoubtedly often made of wood, and bent to the shape of the felly, like our half rims, and used for shoeing the felloe. An example of this mode of tiring may be found in Vol. I., page 43. Poetical license has often manufactured tires out of gold,—*aurea summe curvatura rotæ* (Ovid, Met. 2, 108),—but this was too expensive for practical use. The pole was secured to the under side of the body. Homer tells us that Juno's chariot had a silver pole; but those of mortals, we opine, were made simply of wood—what wood we are not told. The yoke (*jugum*) was attached to the necks of (when more than two) the two central horses. A chariot harnessed to two horses among the Romans was called a *Begæ*; to three, a *Triga*; to four, a *Quadriga*. We would remark, *en passant*, that the *jugum* among the Romans was a significant emblem of humiliation. Whenever they obtained possession of new territory by conquest, the people were made to pass under it in token of absolute subjection to the conquerors. Several examples may be found in Cæsar's Commentaries on his Wars in Gaul, where the proud opposers of his ambitious designs, being subdued, were compelled to submit to this humiliating ordeal. The conquered were supposed to be as effectually *yoked* to the Roman republic, by this ceremony, as were their beasts of burthen to plows or chariots; but history has shown that there is some difference between subduing rational men and the lower animals.

(To be continued.)

## Home Circle.

THIRTY-FIVE.

BY HENRY MORFORD.

Halt on the road a little space!  
Pull up your team, old charioteer!  
You're hurrying on at a slapping pace;  
Suppose we stop and consider, here!  
If our lives are three score and ten—  
If my count is all to be told—  
The half-way house we are passing, then,  
Thirty-five long winters old.

How has the ride been, charioteer?  
Plenty of dust and a little of mire?  
Cold north winds on the hills severe,  
And the air of the valley thick with fire?  
Horses balking, then running away—  
Lynch-pins lost and an axle down?—  
Creeping, crippled, at close of day,  
To a night of rest at tavern or town?

More than this, oh charioteer!  
We have rounded the hills at the flush of morn—  
Heard the sunrise bird sing loud and clear,  
And snuffed the breeze on the blue waves born.  
We have caught such glimpses of Eden vales,  
Heard such sounds by wood and stream—  
Drank such breath on the summer gales—  
As made all life an Elysian dream!

Rough and loud have voices been—  
Pelting and bitter missile and storm;  
But ever at last have we hurried in  
And found some shelter snug and warm.  
Kind, sometimes, have been word and fare;  
Strong and steady the helping hand;  
And erring roads had many a prayer  
Breathed o'er them from the better land!

How much further, charioteer,  
To the end? And he shakes his head.  
No, to the eyes of an olden seer  
Peril is looming near, and dread!  
Tell me not, oh charioteer!  
Bold and blind let me meet my fate!  
Only thus our journey steer—  
So that we wreck at the Beautiful Gate!

Onward, now, but tighten the rein!  
Downward, now, our journey lies!  
Weakened soon will grow hand and brain,  
And the mist comes over failing eyes!  
God be with us, charioteer!  
Keep us with heart and hope alive!  
Sad and short is our stoppage here—  
At the half-way house of thirty-five!

LOTTIE HILL.

BY LUA DELINN.

"DEAD leaves! How suggestive! But no name to tell who placed them here. It must have been that most romantic of all romantic school-girls, Arabella."

"You would do better to think of the most matter-of-fact person you know."

"O no! for then I should say *Lottie Hill*, and it would be absurd to accuse her of anything like sentiment."

"And yet those leaves are the token by which I was to remember Lottie."

"Charlotte Hill? Impossible."

"Charlotte Hill, verily!"

"Beautiful in decay! No doubt they were intended as a vignette to some chapter in her history. But who'd have thought it of *Lottie*?"

"I'm fast finding out that *all* my friends have histories. 'Make a book of them' did you say? I couldn't give them to the public without betraying confidence. O no! I wouldn't for the world speak of them to any one outside of the '*Home Circle*.' Here is a part of *Lottie's*, that I copied just as it fell from her lips; the remainder I shall have to tell in my own way.—

"You love poetry, Lucy, and so, in truth, do I. No one but you would believe me, because I don't interlard my conversation with metrical quotations. When tempted to do it, I am restrained by the thought that most persons who could appreciate poetry would render it better than I; and as for those who have no such appreciation, it would be like giving that which is holy unto dogs. For your sake as well as my own, I should be glad to relieve the hard, harsh prose of my recital with some poetic strains, such as the memories of one's childhood are popularly supposed to awaken. I could not do it without sacrificing truth. When I was about six years old, my parents moved from some place in Virginia, I don't know what, and came to Tompkinsville, on their way to some village in the far west, I don't know where. Here my father died; and my mother, giving up the idea of journeying farther, settled down in an old cabin that stood in the corner of Squire Tompkins' cornfield, just at the cross roads. The hut was in such a wretched condition that the Squire hadn't the face, the *conscience*, he said, to charge anything for the rent. He told my mother that she might settle that with his old woman. Perhaps she could "turn in and help 'em sometimes, when they had an uncommon lot o' hard work on hand. The house wasn't much, but there was room enough in the lot round it to raise a right smart chance o' garden sass; and she could have half of whatever she raised." My mother accepted the offer unhesitatingly, saying it was the best, the only thing she could do. The old house wasn't so very much worse than those we had been used to live in. But its surroundings!—no matter—a correct description would be too prosy. When I begged my mother to go somewhere else, where there were big trees, and grass, like it used to be in *Virginny*, she said I was getting old enough to help along, and that I wouldn't have no more time for playing in the shade. I believe the poetic element exists in different degrees in every nature, but is often crushed out, before it has had the slightest development. Did you ever, in all your life, see a child whose ear wasn't charmed by the murmuring music of the waterfall, the glad, gushing melodies of wild birds; and whose eye, however dull, wouldn't sparkle with pleasure at the sight of green hills and waving woods? I never have, and I've seen all the young Tompkinses of Tompkinsville. Four years my mother and I lived in the one little room at the cross-roads—at least we were there four years as tenants, my mother spending the most of her time helping Mrs. Tompkins with her 'uncommon lot o' hard work,' and I, when not busy with the weeds in the 'garden sass,' was expected to 'mind the children.' You laugh at the expression, but will not question its propriety, when I tell you that it was literally what I had to do. If I failed in any instance to humor their caprices, the dis-

pleasure of their mother fell heavily upon me, and upon my poor, broken-spirited mother. The latter must, I think, have had naturally a yielding disposition; and then she was one of that class who are born without wills, simply to do the bidding of others. She was 'poor white folks.' That was the way we were designated. There were other poor families in the village, but they all, however humble, showed some signs of thrift, were gradually improving in circumstances; we, only, were 'poor white trash.' I remember hearing my mother say once, that she thought when she left *Virginny* she had heard the last of that. She didn't see why they need talk that way in the *free states*. My poor mother! She couldn't see that *here*, the difference between us and others was more strongly marked than ever. I had even then a vague feeling that such was the fact, and have since learned to understand it all.

"When I was ten years old, my mother died. There was no Potter's Field in Tompkinsville; but one marshy corner of the village grave-yard was more dismal than all the rest, so they buried my mother there. Everybody wondered what would become of the girl. Some *reckoned* she would stay at the Squire's; and she'd be a heap better off, for her mother wasn't never o' no account. Others thought the Squire had done more 'n his part already for the family. One man, Mr. Arnott, *guessed* the Squire nor none of his family had done any more than they'd been over-paid for, cause '*twan't their way*.' The woman and her child had had that hut to stay in—'*twan't* half so comfortable as his pig pen—and they'd had a few feet of ground around it, where they could raise vegetables—*on shares*. They'd had some of Mrs. Tompkins's cast-off clothes, that would have been thrown away if it hadn't been for them.

"All the while the woman was working herself to death in the Squire's family, the girl was stunting herself with the weight of the overgrown young Tompkinses. It finally came about that I was the village *protege*; going from house to house as one family after another grew tired of me, and back again, as work was discovered in each household, that the girl could do as well as not. I was quick to learn, and quick in motion; soon learned to cook such coarse fare as the farmers usually had on their tables, to wash and iron, and to sew well enough to make their coarse clothing. But before I had acquired these accomplishments, I became quite an expert field hand; better, except where strength was required, than the men and boys I worked with. Everybody felt at liberty to demand my services. They would even arrange it among themselves, without any reference to me, when I should go to this family, and when to that. Was I *contented*, that I lived on in this way seven years? Not at all; but it was the only way I could think of by which to accomplish something better. Before my mother died, I had learned the alphabet—picking up the letters, one by one, from the children whom I had to 'mind,' while they were trying to learn of the older ones—and had mastered all the easy lessons in Noah Webster's Elementary Spelling Book. There was a large connection of the Tompkinses, as you may have inferred from the name of the village. Every family in the connection had a host of children, so they quite monopolized the teacher of the District School, who 'boarded around' with the different families, so many days for each scholar. It was my good fortune to follow the teacher, for whom special preparation was

always made, and perform the additional labor. In this way I picked up many items of general information, and learned the reasons for sundry operations in Arithmetic, which, when studying by myself, I had despaired of ever understanding, so sorely had they puzzled me. No one suspected that the village drudge had any thought of ever rising above her present level.

"When I was a little girl minding the children, I joined some of them one day, in attempting to say an easy spelling lesson; but they laughed so at the idea of my knowing anything about it, that ever after I carefully concealed my interest and my progress in the simplest studies. There was but one family in the whole settlement that had never required my services, the only one for whom I would have been glad to work. Mr. and Mrs. Arnott said the girl was kept busy enough working for the rest. They never seemed to think it was in their power to render my life less dreary, by giving me, for even a few weeks at a time, a pleasant home in return for services, really efficient, that I could have rendered.

"They had one child, a boy about my age, or only a few months older. This boy, Adam, had often interfered in my behalf, when the other boys, and sometimes the girls, too, had tormented me, as they always did when I happened in their way. When alone in the house or in the field, I never stopped to rest, without devoting the time, however short, to study. For this purpose, I carried with me, everywhere, some book; or, if that was not convenient, a few leaves, of which there were always plenty lying about loose in every house. On several occasions Adam Arnott had surprised me studying, and rendered me valuable assistance. Won by his kindness, I confided to him my plans and hopes, and told him of all I had yet accomplished. He, too, had plans that no one knew of till he told them to me, as we sat among the ruins of the old cabin, in the corner of Squire Tompkins' cornfield.

*(To be continued.)*

## Pen Illustrations of the Drafts.

### SOMERSET CALECHE.

*Illustrated on Plate XXI.*

THE Caleché, of which we give a drawing, is intended to be extremely light and airy, and is well adapted for a summer carriage, on account of the many forms it may be shifted into. The roof in front can be attached to the flap and first and third bows with thumb-screws by any ingenious mechanic. By attaching side curtains it will form a comfortable close carriage for winter. X. Z.

### SPORTING WAGONETTE.

*Illustrated on Plate XXII.*

ON this plate the reader is presented with an original design for a Wagonette, kindly made for our Magazine by Mr. J. Neuss, of Berlin, Prussia. We pronounce it to be a beautiful drawing, and have no doubt our friends will appreciate it. The seats in this kind of vehicle usually extend along the sides and front end, but may be made removable, so as to be placed across the body, for the passengers to ride facing the horses, as well.

### LINCOLN BUGGY.

*Illustrated on Plate XXIII.*

WHILE visiting New Haven, recently, we saw, in the shop of Messrs. S. V. Ingham & Co., the buggy to which our friends have given the name as above. It is an improvement upon the Jagger Wagon, as given on plate VII. of our Third Volume. That was a skeleton body. This is a paneled one. The crooked perch, which should be made of bent timber and iron-plated, to correspond with the shape of the body, gives it a very good and appropriate finish. It will be noted that the back corners of the body and seat are round-cornered. We understand that these buggies have found a ready sale the past season.

## Sparks from the Anvil.

### CHANGES EFFECTED BY HEATING AND COOLING HOOP-TIRE.

RECENTLY, a paper on this subject was read at a meeting of the Royal Society, in London, by Lieut. Col. H. Clerke, R. A., showing the results of experiments interesting to our readers. It seems that the author, when about to tire a wheel with a hoop-tire to which it was necessary to give a bevel of three-eighths of an inch, had it suggested to him, by one of the workmen employed, that the bevel could be given by heating the tire red hot, and then immersing it in one-half its depth in cold water. This was tried, and found to answer perfectly; that portion of the tire which was out of the water, being reduced in diameter. The tire was three inches wide, one-half inch thick, and four feet two inches in diameter.

As the result was curious, and not generally known, the writer made some further experiments, in order to try how far, by successive heatings and coolings, this change could be augmented; and, also, whether the same effect could be produced on other metals than wrought iron. We here, however, give the results only as far as they interest our readers.

The experiments were made on cylinders of wrought iron of different dimensions, both hollow and solid, immersed one-half of their depth, others to two-thirds; also, on similar cylinders of cast-iron, steel, zinc, tin and gun-metal. The specimens were all accurately turned in a lathe to the required dimensions, which were carefully noted: they were then heated to a red heat in a wood-furnace used for heating the tires of wheels. As soon as they had acquired the proper heat, they were taken out and immersed in water, to one-half or two-thirds of their depth, as stated in the experiments. The temper of the water ranged from 60° to 70° Fahrenheit. The specimens were allowed to remain in the water about two minutes, in which time the portion in the air had lost all redness, and that in the water had become sufficiently cool to handle. These alternate heatings and coolings were repeated, until the metal showed signs of cracking, or giving way.

The experiment showed that the general effect is a maximum contraction of the metal about one inch above the water-line; and that this is the same whether the metal be immersed one-half or two-thirds of its depth,

or whether it be nine, six, or three inches deep. With wrought iron, the heatings and coolings could be repeated from fifteen to twenty times before the metal showed any signs of separation; but with cast-iron, after the fifth heating, the metal was cracked; and the hollow cylinder separated all round just below the water-line, after the second heating. Cast-steel stood twenty heatings, but was very much cracked all over its surface. As respects the change of form of cast-iron and steel, the result was similar to that in wrought iron, but not nearly so large in amount. The cast-iron did not return to its original dimensions, but the smallest diameter was one inch above the water-line.

After the paper had been read, Mr. Stokes, the Secretary of the Royal Society, remarked that the cause of the curious phenomenon described by Col. Clerke seemed to be indicated by some of the figures exhibited, especially those relating to hollow cylinders of wrought iron, which are very instructive. Imagine such a cylinder divided into two parts, by a horizontal plane at the water-line, and in this state immersed after heating. The under part, being in contact with water, would rapidly cool and contract, while the upper part would cool but slowly. Consequently, by the time the under part had pretty well cooled, the upper part would be just jutting out; but when both parts had cooled, their diameters would again agree. Now, in the actual experiment, this independent motion of the two parts is impossible, on account of the continuity of the metal: the under part tends to pull in the upper, and the upper to pull out the under. In this contest, the cooler metal being the stronger, prevails; and so the upper part gets pulled in, a little above the water-line, while still hot. But it has still to contract on cooling; and this it will do to the full extent due to its temperature, except in so far as it may be prevented by its connection with the rest. Hence, on the whole, the effect of this cause is to leave a permanent contraction a little above the water-line; and it is easy to see that the contraction must be so much nearer to the water-line as the thickness of the metal is less, the other dimensions of the hollow cylinder, and the nature of the metal, being given. When the hollow cylinder is very short, so as to be reduced to a mere hoop, the same cause operates; but there is not room for more than a general inclination of the surface, leaving the hoop beveled.

#### MACHINE CUT ENGLISH FILES.

FROM the *Ironmonger*, an English monthly, we learn that the manufacture of files is now carried on by machinery, in Birmingham. The blanks are forged by machinery, and afterwards cut with the French machine of M. Bernot. The machine, which is very compact, resembles a small steam hammer in its general appearance. It is provided with a vertical slide, carrying a chisel on the lower end. The top of this slide is pressed by a flat spring, which is governed by a cam mounted upon a shaft, and actuated by a ratchet wheel and pawl; and thus the strength of the blow of the chisel is regulated to the varying breadth of the file. A projection at the other end of the slide comes in contact with a cam upon the driving shaft of the machine, and so sets the machine in motion. The blank to be cut is placed upon a traveling slide, which rests upon a semi-circular bed, which is mounted trunnions resting upon swiveling journals, so that the sur-

face of the blank can be presented at the desired angle to the chisel. The blank is held parallel to the edge of the chisel by means of a weighted leveler.

All being ready, the file is fixed in the bed, the machine is set in motion, and presently the file runs out cut. The chisel makes from 800 to 1,500 cuts per minute, and will produce about five or six times the amount of work which can be supplied by hand-cutting. A comparison of the two modes of cutting—hand and machinery—shows, that, while a machine, to cut 14-inch hard files, makes 1,000 cuts per minute, or 600,000 cuts per day, a good file cutter, upon the same size and description, could only make 140 cuts per minute, or 84,000 per day.

#### Paint Room.

##### STIMSON, VALENTINE & CO.'S VARNISHES.

OUR readers will have noticed the advertisements of the respectable firm heading this article, printed on the cover of this Magazine; but those who wish for further information will not fail to read the very interesting account of the company's establishment, as given by a correspondent, on page 230 of our second volume. Since that article was given to the public we have visited the premises in person, and find them all our correspondent depicted, and the proprietors gentlemen in the best sense of the word. We are also using their turpentine varnishes, and find them just as represented—first-rate articles—none better.

But we designed, in this article, more particularly to call attention to the "Imitation English Varnish" made by this firm. The extreme modesty (or whatever else you may term it) displayed by this house in their business transactions has had such an effect that they have never presented the "Imitation" to the public as strongly as its intrinsic value demands. We have found this out by ordering the article and using it in our own manufactory; and our painter says, "it works just as freely in spreading it, and looks just like it when dry; and he can see no difference between the American imitation and the genuine English." On our part, it only remains for us to see how the weather and time will affect it. For old jobs, in repainting, it is found economical to use it, as it costs much less and looks just about as well. We have only to add that we get nothing for this notice, and give it unsolicited; believing that, in so doing, we are paying a just tribute to genuine merit.

##### ULTRAMARINE BLUE.

OUR correspondent (page 75), in his "Composition of Paints," says that he is unacquainted with the process of making ultramarine, and does not know what it is made of. We supply the following information from *Dingler's Journal*:

The composition for a dark aluminous ultramarine consists of 100 parts of slightly burned kaolin (porcelain clay), 90 parts of soda-ash (95 p. c.), 100 parts of refined roll sulphur, 6 parts of rosin, and 4 of dry pine charcoal. Each of these ingredients is powdered, with the exception of the rosin, which is only added in pieces the size of a walnut when the materials have been mixed, and the whole is rolled together for the space of four hours. It then forms a smooth gray powder, and is loosely packed

into fire-proof boxes, which are covered up, properly luted, and placed on the lower floor; and after closing up all the apertures of the furnace, it is rapidly brought to a point of temperature equivalent to the fusing point of an alloy of equal parts of gold and silver, at which temperature the oven is kept for from five to six hours. By means of small tubes inserted in the front of the furnaces, the process is watched: samples being taken from time to time, by means of hollow cylinder screws. When these samples remain of a green color on cooling, the fire is gradually slackened, and afterwards the draught is shut off; the furnace being left to cool for 28 hours. Two days afterwards the mass is removed from the boxes. It is first broken up under mill-stones, then finely powdered, filled into cast-iron annealing boxes ( $1\frac{1}{2}$  feet high, 2 feet long, and  $1\frac{4}{5}$  feet wide on top, somewhat narrower in the bottom, the iron  $\frac{1}{2}$  of an inch thick), the covers of which overlap the sides. These boxes are placed on the upper floor of the furnace, at the same time that a fresh charge is placed on the lower floor; and are removed about twelve hours after the firing has ceased. This annealing or coloring, which changes the green to blue, by partly oxydizing, and partly removing an excess of sulphur, is similar to the process of coloring red lead.

The blue pigment now obtained is lixiviated, and then, while moist, ground between granite or quartz millstones. When the desired fineness is obtained, the pulp is run into draining bags, and afterwards put in cast-iron dishes, which are also placed in the upper floor of the furnaces to dry, whenever the iron annealing boxes have been removed. On the Rhine, some factories are supplied with reverberatory furnaces, the soles of which are heated from below by the fire, which then again passes over the charge before reaching the flue. Such furnaces hold as much of the crude materials as will yield about 1,300 pounds of ultramarine.

Another method consists in mixing the materials in smaller quantities, and forming them into batches, in boxes containing only about 700 pounds each. These boxes are placed in pairs on the benches of a double floor reverberatory furnace, constructed after the manner of a smalt furnace, heated by one fire, which first passes around the boxes on the lower floor, and from underneath them to the upper floor. The masonry of the lower floor is fire-brick, the supports of both soles and arches being stone, and the upper floor is formed of iron plates. The boxes are made from fire-proof tiles, one inch thick, grooved and let in at the edges. The fuel used is bituminous coal.

### ORNAMENTAL DESIGNS.

*Illustrated on Plate XXIV.*

NUMBERS 1 and 3 were designed expressly for this Magazine; the other, we confess, has been imported, and we therefore have little to say about it. A few remarks in relation to coloring No. 1 may be necessary; but we will leave the rest for young artists to exercise their tastes upon.

No. 1. First, lay gold leaf over the entire figure; then, color the central portion of the band black, leaving the white edges (left in the figure by the engraver) in gold. The ruffled, central figure, and the cords and tassels may be colored with vermilion; the scallops either pale lead or a crimson ground, the lines being formed with black. It is a fine ornament to practice on.

## Trimming Room.

### TRIMMING THE BACK OF A BUGGY.

WE present our readers with two diagrams this month, illustrating the mode of trimming the backs of buggies where a full back is desired.

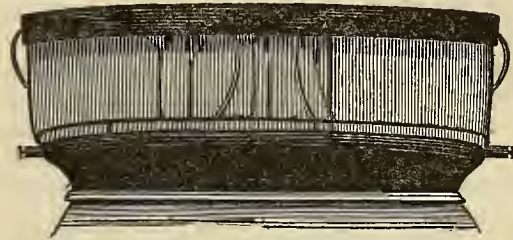

Fig. 1.

The first gives a back view; from which it will be seen that the back is nailed at the top to a common "Lazy-back," on a rail, in the usual manner. This back is covered on the outside with patent leather.

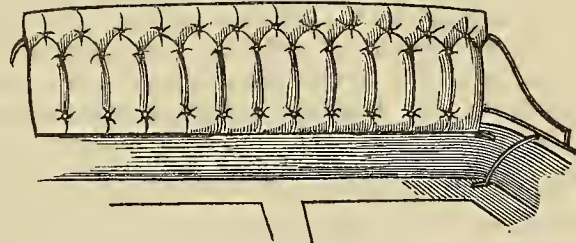

Fig. 2.

The next illustration shows the front side of the back lining with the cushions removed. In this instance we will suppose the lining faced with cloth and lined with muslin. The "pipes," stuffed with curled hair, are made on a back (shown in our first engraving) of dash leather, stiffened with two thicknesses of buckram. We trust this explanation will be found all-sufficient for the instruction of the trimmer; and, therefore, dismiss the subject by stating that these backs are applied to rails formed similar to those shown on pages 43 and 44 of this volume, making what is called a close-back.

### LUSTROLÆ, OR LEATHER VARNISH.

A FRENCHMAN has recently patented a new article of varnish for leather, which is attracting some interest among the Parisian carriage-makers. The discoverer has published an account of his invention in connection with the history of leather varnishes generally. From this we condense for our pages his remarks on the subject.

About forty years ago, the only material in use for varnishing leather was a frightful mixture called egg-polish. Polish of the leather, however, it was not; since it merely lay on the leather, and so glistened, without in any way entering it. It possessed very little cohesion, and, hardening the leather, rendered it liable to crack; and, at last, after repeated applications, became conglomerated to such a thickness on the leather, that it was necessary to scrape it off with a knife, very carefully used. At the commencement of the Restoration in England, blacking of various kinds was exported into France. These were applied to the leather with a brush. Here was progress; for the blacking penetrated the leather, and did not cause it to crack, while its oily nature, in a measure, protected the leather to which it was applied. But, unfortunately,

to render all these blackings durable, it was necessary to have recourse to acids, the corrosive nature of which ended by drying, or, rather, *burning* the leather, so that, wherever the most stress was exercised upon the material, there it broke.

After this followed the introduction of varnished leather, which does not date more than thirty years back. This, on its introduction, was comparatively contemptible, compared with the state of beauty which it exhibits at the present time. At that day it was passed through hot stoves, whence it came out half destroyed by the action of the fire: hence, varnished leather was exceedingly expensive, owing to the extreme shortness of its duration. This necessitated the introduction of a varnish to fill up the cracks—which was the forerunner of the final disruption of the leather—and this varnish has remained in vogue to the present day. Owing to the fact that varnished leather, no matter in what way used, is generally required for use almost immediately after the application of the varnish, and before it has had time thoroughly to dry; the consequence is, that the surface of the leather gradually becomes corrugated by the adhesion of dust; and the result is, that no amount of polishing will yield a pure, brilliant surface. The new aspirant proposes to remedy all this by using the “Lustrolæ,” which, he says, is composed of oleaginous matters having the peculiar virtue of restoring leather to all its original brilliancy. Patent leather treated with this varnish will last many years, so efficacious is its effect; while, at the same time, it imparts an admirable polish. If the Frenchman accomplishes one half he promises, he will receive, as he deserves, the gratitude of all carriage-makers in the world.

### Editor's Work-bench.

#### TO OUR FRIENDS.

WITH this number, we once more resume our regular monthly issues; trusting that the effects of our national difficulties have so far been overcome as to induce our friends to come forward with their generous subscriptions in such numbers as to insure us against serious losses, while we are studying to profit them. We are happy to say—though our time has been gratuitously given—that by economy, and a bi-monthly issue for the past two years, we have managed to weather the storm so disastrous to others, and come off with our spars and masts all standing. We hope to have smoother sailing hereafter. Indeed, if we may judge of the future by our sales the past two months, our old success has already in a measure returned.

In connection with the above, we would mention that we have a few sets of this work still on hand, and for sale, bound in muslin, gilt, and only charge for the four volumes \$12, at the office. If sent by mail, postage paid, \$14. If by express, with bill for collection, \$13. Either of the first three volumes may be had at the office for \$3.50 each; the fourth volume for \$4. The four volumes, in numbers, will be mailed to any address on re-

ceipt of \$10, postage being paid by the receiver. Persons desiring a set of this work had better send for it soon, as, not being stereotyped, the opportunity to purchase may soon pass away. To the carriage-maker these volumes are invaluable. They treat upon all subjects pertaining to carriages, and the plates serve as one of the best means for securing custom. The simple drawing often strikes a visitor's fancy, when shown, and induces him to have a carriage built. Try it, as we have done, and no doubt you will acknowledge that your \$12 was used to a good purpose. As a book of reference, the patent journal alone is worth more than we charge for the volumes. Then there are examples in the so-called French rule, never so correctly given before; lessons in drafting carriages; instructions in painting; ornamental designs, and other useful matters we need not enumerate—all nowhere else to be found. Send along your orders. They will receive immediate attention.

#### COMMERCIAL REVIEW OF AMERICAN CARRIAGE-MAKING.

CONTRARY to all anticipations, the sale of carriages for the past season has far exceeded that of other years; in fact, the demand, in this locality, has exceeded the supply in some of the lighter kinds of work. Manufacturers have some difficulty in obtaining help, particularly in the wood-work and blacksmithing departments. Some of the wood-workmen, we are told, are making \$3 and \$4 per day. It is an undisputed truth, that *good workmen, at this time, have things about all in their own way.* The reason is, they are scarce. The dull times at the beginning of the Rebellion *drove* them into the army, where many of them have died fighting in the cause of freedom. Some few engaged in other employments. These two circumstances, together, have contributed to bring around the harvest our journeymen are now reaping. We advise them to improve it, for this state of things cannot be lasting.

We hear a good report from the western portion of our new country, and are told that business is thriving; so of the Western part of this State and portions of the State of Massachusetts. But the most anomalous thing is—*we hear of but few that will admit they are making any money.* This may appear strange to the uninitiated; but it may in a measure remove much of this doubt to say that, while for many articles we pay 40 and 50 per cent. higher than formerly, we get but about 25 per cent. more for the manufactured article. This, of itself, is evidence of a bad state of things; and, when the excise man comes in for a share of the small profits awarded the carriage-maker for his labor, we see that his chances of getting *independently rich* are becoming “smaller by degrees, and *discouragingly* less,” as time advances.

We have been asked, “What effect would peace have

on the carriage-making business?" We candidly confess that *we* cannot tell. We, however, venture a few "speculations." Suppose an enterprising manufacturer was to get up a large stock of carriages this Winter, paying the high prices now ruling for stock and labor, and then, in March or April, with the return of peace, everything should come down in price,—who does not see that he must loose money? for, undoubtedly, with the fall of material comes also the fall of the manufactured article. We are disinclined to even hint at a contingency which, in effect, serves to check a laudable ambition; but, we opine, from the present state of our political history, that we are standing upon a volcano, which, when it bursts out, will destroy the hopes and dispel the avaricious dreams of many people. We can only hope that the storm may be long distant, while we pray for a speedy return of peace.

#### PAYING WORKMEN IN STORE ORDERS.

In some portions of this country the boss carriage-makers have been in the practice of, weekly, paying off their hands with a part of the wages due them in orders for groceries, &c., at some store—in some instances, it has been asserted, where the payer had himself some pecuniary interest. Especially was this the case in Rahway, N. J., in its more prosperous days. This system is decidedly wrong; for it is well known that in most cases, with cash in hand, a purchaser can do better with it than by orders on certain individuals. With the money, he goes where he chooses—where he can buy the cheapest; with an order, he has no alternative—he must pay just what the shop-keeper charges. We are glad to find that there are indications of reform, in this particular, in some parts of the Union.

The Pennsylvania Legislature has recently passed a law on this subject, which provides that "It shall not be lawful for any iron-master, foundry-man, collier, factory-man or company, their agents or clerks, to pay the wages or any part of the wages of workmen or laborers by them employed, in either printed, written or verbal orders, upon any store-keepers or shop-keepers or other dealers in merchandise, or other articles, whether connected in business with the said iron-master, foundry-man, collier or factory-man, or not. Any iron-master, foundry-man, collier or factory-man, paying to the said workman, so by him employed, or authorizing their agent or agents to pay any part of the wages of his said workman in orders upon any such store-keeper, shall forfeit the amount of said order or orders so given or paid; the same shall not be defalked against the wages of said workman or laborer; and he shall be entitled to recover the full amount of his wages as though no such order or orders had been given or paid, and no settlement made with such employer shall bar such recovery; and any iron-master, foundry-man, collier or factory-man, offending against the provisions of

the first section of this act, shall be guilty of a misdemeanor; and, upon conviction thereof, shall be punished by a fine and imprisonment, or either, at the discretion of the court trying the same; and, provided further, that this act shall extend to all seamstresses or females employed in factories or otherwise."

The system of paying in store-orders is a relic of the olden times, when "legal tenders" were scarcer than now, and it gives us genuine pleasure to chronicle any move towards their suppression. Their longer continuance, in any form, ought not to be tolerated or countenanced by either employers or the employed. A little determination on the part of workmen is all that is now necessary to terminate this evil.

#### CARRIAGE-MAKERS' DISSATISFACTIONS.

WE often hear some dissatisfied fellow-tradesman, in a fretful mood, saying: "This is the meanest business a man ever engaged in. One can make more money as a common day-laborer than by carriage-making." Such conclusions are decidedly wrong. This systematically whining class of men will never succeed in any business undertaking. They are not the stuff rich men are made of—they are deficient in that article we call energy—in that fixedness of purpose which is requisite in order to make successful any pursuit in life—they never have what some people define as "luck." Now, to our mind, *luck* is but another term for industry, and, did some others realize this, matters would improve with them.

Men never make a greater mistake than to suppose they can find any business exactly suited to their peculiar fancies; to think that their neighbors are traveling a smoother road than themselves. The charm only consists—in this case—in the fact that "ignorance is bliss," and "things are not what they seem." When we learn the precise state of things, we discover that every business undertaking has its peculiar vexations, and there is no use in leaving the business you know all about, to engage in another, blindfolded. Instead of retreating, exert every power in overcoming seeming difficulties, and in most cases you will succeed. Constant effort, steadily persevered in, will add new pleasure to your occupation, and give you confidence of finally obtaining a remunerative reward. Ours may appropriately be termed one of the fine arts, and he whose heart is studiously engaged at it will find it both pleasant and moderately profitable.

#### EDITORIAL CHIPS AND SHAVINGS.

AN EDITOR IN DISTRESS.—The editor of the *Journal of Arts and Manufactures for Upper Canada* is very much troubled by the remarks made by us in the September number of this Magazine, and says we made a "sorry mistake" in charging "the tricky ticket vendor" of the Grand Trunk Railway with speculation when he took our two-dollar Canadian bill, for a passage from London to

Stratford, and refused to pay us back the change in kind. He tells us that "a single question from any one on the cars would have satisfied him [us] that silver and Canadian paper were at par, on this line, at the time." Our excited cotemporary may rest assured we knew it all, if the concession is confined solely to Canadian issues; but this does not negative the fact that we had ourselves already paid—in Canada, too—a premium of forty cents on the dollar, and that the same was then worth to us, on our return to New York, forty-five cents. We had the best of reasons for inferring that the Grand Trunk managers knew the value of Canada money as well as we did; for we found out, without asking, that a general complaint was made by the passengers on the cars that, whenever they offered a bill, they never could get back change in kind, on this line. Many of them even went so far as to say that, was it not for a law forbidding it, the managers would put provincial issues on a level with American silver, and shave it at the rate of 8 cents discount. But there are none found so blind as those who have eyes and yet won't see. Such, we think, is our distressed cotemporary; and, knowing the folly of arguing with a mad man, who, for aught we know, may be one of the stockholders of the company of which he seems to have been appointed the Cerberus, we abandon him to his fate, hoping that he may be more successful in conducting the *Journal* than he has in attacking us.

**NAPIER'S BATTLE CHARIOT.**—From the manuscript papers of Anthony Bacon, lately examined in the Lambeth Library, England, it appears that one John Napier, of Merchiston, as early as A. D. 1596, among other "secret inventions, profitable and necessary for the defence of England, and withstanding of strangers, enemies to God's truth and religion," proposed that of "a round chariot of metal, made of the proof of double musket, whose motion shall be such that those that be within the same shall be more easy, more light, more speedy, and more safe in battle, than any hitherto contrived. The use hereof in moving is to break the array of the enemy's battle, and to make a passage, as also staying and abiding within the enemy's battle. It serveth to destroy the environed enemy, by continual charges and shot of the harquebuse, through small holes, the enemy in the meantime being abased, and altogether uncertain what defence or pursuit to use against a moving mouth of metal."

**RECIPES FOR COMPOUNDING AXLE GREASE.**—Dissolve half a pound of common soda in one gallon of water, add three pounds of tallow and six pounds of palm oil (or ten pounds of palm oil only), heat them together from 200° to 210° Fahrenheit; mix and keep the mixture constantly stirred till the composition has cooled down to 60° or 70°. A thinner composition may be made with half a pound of soda, one gallon of rape oil, a quarter of a pound of tallow or palm oil, and a gallon of water.

Another compound is prepared by using one part of fine black-lead, ground fine and mixed with four parts lard. Add to all a little camphor.

**PADDY'S POETICAL HORSE.**—At a town in Ireland the drivers of several jaunting-cars were competing for the honor, but especially the emoluments, of conveying a gentleman on his journey. One urged his claim on the ground that his horse was a *poetical* horse, and, "of course, the gentleman would prefer a *poetical* horse." Such a curiosity was irresistible, and so the *poetical*-horse jaunt-

ing-car and driver were engaged. After having gone some little distance, and rather slow, the gentleman remarked to Patrick, "Your horse does not go along very fast." "Oh, no," replied Pat, with a sly shrug of the shoulders and a peculiar twinkle of the eye, "he is a *poetical* horse, sir." Wishing further explanation, Pat enlightened the gentleman as follows: "Why, sir," said he, "you see the horse's speed is *more in the imagination than in the reality.*"

**WESTERN TRAVEL.**—A correspondent, living near Omaha City, Nebraska, says, that "the roads in that vicinity are covered most of the time with wagons, some of them going to Pike's Peak and others to Washington Territory, California, and Oregon. Most of these are ox-teams. There are nine-hundred wagons going through to the mines, escorted by one hundred cavalry. A horse train, consisting of about twelve hundred wagons, is already about 300 miles ahead."

**THE BEST PLACE TO BUY YOUR LAMPS.**—Carriage-makers in want of lamps will find it to their advantage to call on Messrs. Cary & Young, whose advertisement appears on the third page of the cover to this Magazine, before purchasing elsewhere. We are personally acquainted with them, and know them to be fair dealers, either in quality or prices. They make the most fashionable and tasty lamps—a specimen of which we here give in illustration—and sell them more reasonable than any manufacturers we are acquainted with. City manufacturers will also find, at 43 Greene Street, bands, pole crabs, shaft tips, and almost anything in the plated line they require, as well as have their plating done immediately.

**MONTHLY ISSUES RESUMED.**—With this number, as before announced, we again begin our regular monthly issues, trusting that in so doing our generous friends will not forget to send us all the subscribers they can influence within their circle of acquaintances. For over two years we have given our time to this Magazine without remuneration, and, we think, the fact only need be made known to enlist the sympathies of the craft, that of our Western friends especially. Fifteen minutes through your shops, with pencil and paper, would greatly increase our subscription list, and contribute to make this work more useful. Suppose you try it.

**SEVENTH AVENUE (N. Y.) CARRIAGE DRIVE.**—It is in contemplation to widen the Seventh Avenue to 150 feet, and then to lay out a park, the entire length, 30 feet wide, with a bridle-path for equestrians. Four rows of shade trees will divide the side-walks and bridle-path from the carriage drives; so that a section of the road would represent a bridle-path in the center, 30 feet wide, bordered on each side by a row of trees, and a carriage drive 38 feet wide, with a side-walk on both sides, each 22 feet wide. Should this plan be carried out, additional encouragement to purchase carriages would be given to the public, and, consequently, the interests of the trade be promoted.

#### LITERARY NOTICES.

SINCE our last issue we have received both the September and October numbers of the *Atlantic Monthly*.





The first opens with "The Puritan Minister," and is the best thing we have read in many years. Every New Englander will see that it is a life-like sketch, by a worthy descendant of an early Puritan, true to the letter. The October number is equal to any preceding it, which, where all are first-rate, is saying much. We are really sorry space admonishes us to be brief, and that we can only say to our friends, that we consider the *Atlantic* the prince of monthlies and a credit to American literature. It should find a place in every library.

Are any of our readers owners of a garden? Such should send for *The Rural New-Yorker*, published by D. D. T. Moore, Rochester, N. Y.—the best rural, literary, and family newspaper published in the world, and all for only \$2 a year. Try it for one year. A new quarter begins with October 3d; a good time to subscribe.

#### FOREIGN IMPROVEMENTS IN CARRIAGES.

**RUNNING-GEAR OF FOUR-WHEEL CARRIAGES.**—June 30, 1862. W. Thomas, of Liverpool, takes an omnibus body of a convenient form, supported on springs of any kind, resting on, suspended from, or in any way attached to the axles, and the carriage-parts fluted in the ordinary manner. On the axle, near the inner ends of the hubs of every wheel, are secured brackets which carry studs, pins, or bolts for receiving the ends of the tension-rods of the equirotal lock arrangement or system. These rods are made preferably of metal, and are carried diagonally from the near-fore to the off-hind wheel, and from the off-fore to the near-hind wheel. To prevent friction and flattening of such tension-rods the patentee uses four or more friction rollers, so arranged in a frame or bracket that the rods shall be kept a sufficient distance from each other, and the friction reduced to a minimum, both in turning and doing the shaking and jolting in straight running. The gear to which the pole of the omnibus is fixed, as well as the gear permitting quick turnings to be made, is the same at both ends, and the main parts of each end consist of four metal tension-rods, two or more elliptical shape, or other wise formed, metal bars, rods, or springs, a futchel piece, and a curvilinear metal forging, with a bracket or brackets, and friction roller or rollers therein. All the tension-rods are jointed on studs, pins, or bolts, secured by brackets or otherwise to the axle, two at or near each end of the same and close to the inner ends of the hubs of the wheels. One of these tension-rods at each side is carried forward to or near to the front or end of the omnibus, and is then coupled by a joint to two or more elliptical or other metal bars, rods, or springs. The other two tension-rods are carried forward and almost meet near the center of the said elliptical or other bars, rods, or springs; and the socket for the pole is secured in the same position, that is, equidistant from the ends of the elliptical or other bars, rods, or springs. The bracket is secured or jointed to the said socket piece, to the elliptical or other bars, rods, or springs, or to both, or either of them, and pass and encompass a curvilinear, or other suitably formed metal forging, principally in a horizontal position, made fast by flanges, or otherwise, to the bottom of the body of the omnibus. This curvilinear piece, which carries the whole of the fore-draught gear, allows the bracket or brackets, and the elliptical or other bars, rods, or springs, as well as the tension-rods, to travel or move laterally a sufficient distance for quick turning of the omnibus, friction being diminished by a roller or rollers in the ends of the said bracket or brackets. A further

improvement in running-gear consists in making the naves of the wheels, of the kind known as the "patent mail wheel," of iron, instead of iron and wood combined—the sockets for the wooden spokes being cast or formed in the hub.

**CONSTRUCTION OF OMNIBUSES, &c.**—July 1, 1862. E. F. Prentiss, of Birkenhead, has invented and patented a mode of applying the running-gear to four-wheel carriages so as to facilitate turning, and so that they may be driven either end foremost; and, also, to a peculiar construction of light body for passenger carriages, which it is proposed to call the "skeleton," or "spider," chariot. The first part of these improvements consists in constructing and fitting both the front and hinder axle-trees of four-wheeled vehicles in such a way that they will both turn horizontally round on their vertical axle-pins (or "perch bolts") a given distance in connecting the two axle-trees together by two curved connecting rods. One of these rods the patentee joins to the front axle-tree near the nave of the rear wheel, and carries it across to the hinder axle-tree, and joins it thereto near the inner side of the off-wheel; and the other rod he joins to the front axle near the off-wheel, and which he also extends to the hinder axle, to which he joins it in like manner near the inner side of the near-wheel. By this arrangement it will be readily seen that, if the leading wheels are turned towards the left, the two wheels on the left side of the carriage will be brought toward and at a right angle to each other; and that the two wheels on the right side of the carriage will be proportionately separated from each other, when the carriage can be readily turned toward the left, and, by turning the leading axle toward the right, the reverse motion will take place in the wheels and the carriage can be turned in the opposite direction. The second part of the invention relates to the construction of light carriage bodies for open passenger vehicles, and consists in a light parallelogramical frame of wood, angle-iron, or other suitable material, between and from the longitudinal sides of which spring a number of l arched spanners of wood, fluted with metal tie-rods; or they may be constructed entirely of metal. On the corner of the arched spanners he constructs a vertical longitudinal railed, or other suitably shaped, back, for longitudinal seats fitted on each side thereof. The seats he prefers should be cane-seated frames, fitted with hose cushions. The foot-rests and the stages at each end of the body he proposes to form of light open grating framework, and to surround the whole with a light rail, or light open frames, or closed panel work, except at the openings left for ingress and egress. He further proposes to erect two or more standards, extending above the center back rail, for supporting a suitable double hood, which can be let down at both or either side of the carriage.

**APPARATUS FOR ASCERTAINING THE FARES AND EARNINGS OF PUBLIC VEHICLES.**—Aug. 14, 1862. N. J. Curtis, Holloway, Eng. In adapting this invention to a cab or omnibus the inventor provides a packet of cards, having on their faces a graduated dial, numbered and representing distances, in miles, half miles, and quarter miles if necessary. Each omnibus passenger or hirer of a cab will receive one of these cards on entering a vehicle, it having been pierced by a punch to indicate a starting point on the dial. On leaving the vehicle the card is to be again pierced, and the distance between the two nicks in the card will show the distance traversed. The punch will,

however, when making the second nick, which indicates the termination of the passenger's journey, strike out a portion of the card, and discharge it into a receiver, which is accessible only to the proprietor of the vehicle. This punched out portion will have a counterpart of the nicks retained by the passenger, and will, therefore, show the amount of the fare chargeable to the passenger. *Not proceeded with.*

**CONSTRUCTION OF WHEELS AND AXLE-TREES.**—Aug. 29, 1862. Wm. Uphill, W. Morton, and W. Ashing, of Birmingham, have patented a novel mode of constructing and combining the hubs and axle-boxes of wheels, and also of securing the hub or axle-box of the wheel to the axle-tree. In carrying out this invention the hub and axle-box are constructed separately; but previously to being adapted to the axle-tree they are secured together by screwing or otherwise. The hub, which receives the spokes, is bored out, or cast with a hole to fit on to the axle-box, on which it is secured by a screwed cap or bolts, or otherwise. By this means the hub with its cap and axle-box are connected together, and form one piece, which is secured on to the axle-tree by means of tongues, pins, studs, or projecting pieces, which are made to take into a groove or grooves cut or made round the axle-tree. These are made movable, and are inserted in dovetailed grooves or sockets made in the metal washer, which is by preference cast on to the end of the axle-box, but may, if desired, be made separate; and, in order to prevent these tongues or their equivalents from coming out accidentally, they are secured in their places by cross-pins or screws.

**MANUFACTURE OF AXLES.**—Sept. 25, 1862. E. G. Muntz, of Birmingham, has invented and proposes to employ cast and wrought iron or steel in combination in the manufacture of axles. He takes for the arm or center of the axle a bar or fagot of wrought iron or steel, around which he casts iron or steel; he thus obtains the form of the axle by casting, saving the labor of forging, while the wrought iron metal in the center affords the requisite tenacity. *Not proceeded with.*

**CONSTRUCTION OF AXLE-BOXES.**—October 6, 1862. C. Chinnoek, of Queen's-road, Regent's Park, London. As declared by the inventor, the chief object of this invention is to neutralize or remove the friction that is now created between the axles and axle-boxes of carriages, caused by the lateral pressure of the wheels against the collars or shoulders of the axles. This is effected by coupling together the axle and axle-box, by means of anti-friction balls, in such a manner that, when a cap is used for closing the axle-box, the connection may be readily made and maintained on the temporary removal or displacement of this cap, without risk of the anti-friction balls dropping out of place. By a modified arrangement he is enabled to provide against the displacement of the balls on the removal of the box itself from the axle.

**COVERING STREET OMNIBUSES.**—October 13, 1862. A. F. Gallis, of Dean Street, Soho, London. In carrying out this invention the iron rails are higher than usual, the actual height of them being still increased by a curtain which passes all round the omnibus. In wet weather the conductor requires but a few minutes to raise the cover, and a still shorter time to let it down, together with the upper rails, after the rain has ceased. Lateral openings in the cover serve to check the action of the wind. These

openings can easily be closed and opened again by the passengers. The invention further consists in a mechanical contrivance by which a number of solid iron or other bars, contained within iron or other tubes, may, by means of chains, &c., worked over rollers with a handle within easy reach of the conductor, be raised to the proper height to support the covering or awning. The water-tight covering or awning lies folded up, in fine weather, behind the driver's seat. When required for use, the conductor simply draws a string attached to the cover, when it then glides easily over the bars, by means of rings or otherwise. When it is no longer required, the driver pulls it back by another string behind him.

**HANSOM CABS.**—Oct. 14, 1862. J. Snyder, Jr., of Dorset Street, London, applies to the forward part of the top, or front of the vehicle, a folding or movable cape or curtain, sustained by a frame, and which can be projected and retracted at pleasure, and which is primarily destined to serve as a protection from the weather in lieu of the present inside folding glass, or framed shutters or flaps called "the glass," but also as a sun-shade.

**SCREW LINCH-PIN FOR CARRIAGES.**—October 17, 1862. J. Smith, of Egdon, near Worcester. This invention consists in making an aperture in the linch-pin large enough to receive a screw; a hole is then drilled from the end of the arm up to the linch-pin, and the screw is then applied and fixed in the aperture of the linch-pin. This arrangement prevents the possibility of the linch-pin falling out. *Not proceeded with.*

#### AMERICAN PATENTED INVENTIONS.

May 5. **APPARATUS FOR UPSETTING TIRES.**—M. P. Larry, of Windham, Maine, antedated Jan. 16, 1863: I claim a tire-shrinker, constructed, combined and arranged as above set forth and described.

**PARALLEL VISE.**—N. P. Otis, of Yonkers, N. Y.: I claim, *First*, The strap D, and bar C, applied to the part *a* of the shank, or pillar B of the vise, and connected by the keys E, when the said part *a* has any angular or irregular form which will adapt it to be firmly held, substantially as and for the purpose described. *Second*, The combination of the cross-bars J J, bar C, strap D, shanks or pillars B H, swivel jaw A, permanent jaw I, screw G, and socket F, when arranged as shown, to form an improved article of manufacture for the purpose specified.

**MACHINERY FOR DRESSING AXLE-BOXES.**—William Hamilton, of Alleghany, Pa.: I claim facing both ends of an axle-box at the same time, by means of two cutters placed parallel to each other at right angles to the axle of the axle-box, which is caused to revolve on its axis, the cutters being so operated as to approach each other as the box is being faced, in the same relative position to each other, and to the axis of the axle, substantially as described. The combination of cutters for facing the ends of the boxes, placed at each end thereof, and susceptible of motion toward each other while preserving a given angle of inclination to the axis of the box, with a mandrel for holding the box from its inside, capable of opening on each side of its center, for the purpose of holding the axle-box with its axis at the proper angle to the cutters, and yet allowing the cutters to pass beyond the point of contact of the exterior surface of the mandrel, and the interior circumference of the axle-box, substantially as described. The use of an adjustable gage, interposed between the two cutters, for the purpose of stopping the operation of the machine when the axle-box has been faced down to the required length.

**ELLIPTIC SPRING.**—Richard Vose, of New York city: I claim the combination of one or more curved metallic bearing plates, A and A', with one or more curved metallic tension plates, B

and B', when said plates are arranged in planes at right angles to each other, substantially as herein set forth. When bearing plates A and A' are arranged and combined with tension plates B and B', in the formation of an improved spring, substantially as herein set forth, I claim confining and securing said plates by means of the metallic heads C C and D D, or their equivalents, substantially in the manner herein described. I also claim the use of intermediate compensating springs, when combined with the bearing plates A and A', and tension plates B and B', of my improved spring, substantially in the manner and for the purpose herein set forth.

12. FASTENING TIRE ON WHEELS.—Wm. C. Whiting, and Henry F. Edwards, of Worcester, Mass.: We claim a metallic plate, with any number of prongs on either or both ends, introduced between the tire and felloe in the manner and for the purposes set forth. [We would like to know if this is the invention of any practical carriage-maker. We deem all such *contrivances* a direct injury both to the mechanic and his customer. Nothing short of resetting a loose tire will effect any practical good.—Ed.]

19. COMPOSITION FOR WELDING STEEL.—Andrew Briggs, of Lowell, Mass., antedated Aug. 8, 1862: I claim the composition of matter consisting of the above-named ingredients, substantially as described and for the purpose set forth.

APPARATUS FOR CLIPPING BOLTS AND RIVETS.—Zephaniah B. Coutant, of Greenwich Station, Ohio: I claim, in combination with the jaws B and E, the stump H, and screw K, for the purpose set forth. I also claim the general construction and arrangement of devices described, forming the improved bolt and rivet clippers or cutters.

METAL-PLATED SHOES FOR CARRIAGES.—John DuBois, of Williamsport, Pa., antedated May 15, 1863: I claim the flanges *b b*, and their fastenings, clamps *c c*, and keys *e e*, when combined with a broad runner, and constructed to operate substantially as described and for the purposes set forth.

CARRIAGE HOLD-BACK.—Rufus Nutting, of Randolph, Vt.: I claim, *First*, The adjustable hold-back A, I, K, F and H, or its equivalent, in combination with the spring B, or its equivalent, for thills or shafts for the use of one-horse teams, or poles for two-horse teams, substantially as described. *Second*, The chafe-plate D, or its equivalent, in combination with the hold-back A, I, K, F and H, substantially as described and for the purposes set forth.

CARRIAGE COVER.—James I. Rankin, of Astoria, N. Y., antedated April 2, 1863: I claim the suspended cover, constructed substantially as described, and provided with cords and pulleys, all arranged to operate as and for the purpose herein set forth.

PAINT OIL.—Adolph Millochan, of New York city, assignor to himself and Alfred Birney, of Jersey City, N. J.: I claim as a new product an article of manufacture, the paint oil, of a character substantially as described, produced from the acid residuum remaining after the purification of petroleum or coal oil, or other bituminous oils, in the manner set forth.

PROCESS OF PREPARING OIL AS A SUBSTITUTE FOR LINSEED OIL.—Adolph Millochan, of New York city, assignor to himself and Alfred Birney, of Jersey City, N. J.: I claim the combination of these two methods, the whole together constituting a new and useful process for making a fine, clear and limpid paint oil from the acid residuum remaining after the purification of petroleum, coal oil, or other bituminous oils, substantially as described. [We would remind our friends that all *aciduous* oils must have a more or less injurious effect on colors, and are altogether unsuited to the interests of the coach-painter.—Ed.]

26. DRAFT CLIP-TIE FOR CARRIAGES.—Philos Blake, of New Haven, Conn.: I claim the combination of my elongated clip-tie with an elastic presser, when constructed and fitted to produce the result substantially as herein described. *Second*, I claim the combination of the cap with the elastic presser, when so constructed and used that the cap will insure the entire equilibrium of the presser, as well as prevent it from wearing, substantially as herein described.

OMNIBUS AND CAR REGISTER.—Rowland Cromelien and William R. Crisp, of Washington, D. C.: We claim the hollow shaft B, No. 1, to carry arms of turnstile in combination with

lock-plate D, Nos. 1, 3, 4, and the latch B, Nos. 1, 3, 4, and connecting rod F, Nos. 1 and 2, thereby presenting its use only at the will of the party in charge. We further claim the arrangement of the turnstile in the interior of the car, without injuring the appearance or destroying any part of the same.

CARRIAGE WHEEL.—George W. Gilbert, of Radnor, Pa.: I claim the axle-box B, with its flange B', nut E, and washer F, in combination with the plate A, and the spokes D, fitted to each other and to the box, as described, and secured to the spokes by bolts *a a*, the whole being constructed and arranged substantially as and for the purpose herein set forth.

WAGON BRAKE.—John Row, of Mantorville, Minn.: I claim the arrangement of the lever C, hinged to the front end of the draught-pole A, and connecting with the hold-back straps in combination with the hinged lever E, draught-chains H H, and sliding brake F, constructed and operating in the manner and for the purpose substantially as specified.

JUNE 2. HANGING CARRIAGE BODIES.—Edward Lane, of Philadelphia, Pa.: I claim hanging the body of a vehicle to the front and rear axles of the same, by means of the gum-elastic springs H H and H' H', the levers D D and D' D', the rods G G and G' G', or their equivalents, arranged as set forth, when the spring of one lever is independent of the springs of the other levers, as described, for the purposes specified.

CARRIAGE BRAKE.—M. K. Lewis, of Iowa City, Iowa: I claim, in combination with a cam-shaped brake block arranged to turn on the brake bar, the links or chains which connect it to the axle or some parts of the carriage, substantially as described, for the purpose set forth.

16. MACHINE FOR ROUNDING TENONS.—Ira L. Beckwith, of Providence, R. I.: I claim the improved spoke-tenoning tool or machine, as provided, not only with the separate guide tube B, and its socket *g*, but as having one or more adjustable cutter-carriers *k k*, made and applied to its stock A, substantially as herein before specified. I also claim the guide tube B, as made with a recess *i*, for the reception of the cutter and its carrier, such recess being arranged in the said guide tube, as and for the purpose specified. I also claim the arrangement of the cutter-rest *f*, the adjustable cutter-carrier *k*, and the clamping and adjustable screws or devices *n n*, of the latter.

INDIA-RUBBER WHIP SOCKET.—Charles Goodyear, Jr., of New York city: I claim the manufacture of soft, vulcanized india-rubber whip sockets, and substantially as hereinbefore described.

30. COMBINED COLLAR AND HAMES FOR HORSES.—S. B. Stewart, of Center Township, Pa.: I claim, *First*, The combination of the collar A and hames B, substantially as described, so that they shall form but one piece as set forth. *Second*, The combination of the tenon C, ferrule D, strap *d*, staple *e*, and hooks *e'*, as described, for the purpose of uniting the two sides of the collar as set forth.

July 21. MACHINE FOR COMPRESSING CARRIAGE WHEELS.—George Cook, of New Haven, Conn.: I claim the arrangement described, of the ring F, screws H, and bracket I, when the same are combined in the manner and for the purpose as herein substantially set forth.

WHEEL VEHICLE.—C. S. Manning, Springfield, Ill.: I claim the springs C, composed of two principal parts *a c*, connected together by a link *b*, and secured to the axles B, and to the vehicle, in the manner substantially as herein set forth.

28 WAGON.—L. M. Ham, of Boston, and J. H. Dodge, of Chelsea, Mass.: We claim, *First*, The means herein described for obviating the strain upon the center-bolt or rod of the front axle-tree, the same consisting of the connecting chain *n*, and fixed staple *v*, arranged with regard to the same, and operating substantially as specified. *Second*, The arrangement of the pole with regard to the body, the spring and futchells of the front axle-tree, substantially as herein described and for the purpose specified.

APPARATUS FOR HEATING WAGON TIRES.—Samuel G. Reed, Worcester, Mass.: I claim the application of gas for heating tire. I also claim the apparatus for heating when constructed in the manner, or its equivalent, substantially as and for the purpose set forth.

## CURRENT PRICES FOR CARRIAGE MATERIALS.

NEW YORK, October 14th, 1863.

Apron hooks and rings, per gross, \$1.25.  
 Axle-clips, according to length, per dozen, 50c., 63c., and 75c.  
 Axles, plain taper, from  $\frac{3}{4}$  to 1 in., \$5;  $1\frac{1}{8}$  in., \$6;  $1\frac{1}{4}$  in., \$6.50.  
 Swelled taper, 1 in. and under, \$5.25;  $1\frac{1}{8}$  in., \$5.75;  $1\frac{1}{4}$  in., \$6.75;  $1\frac{3}{8}$  in., \$8.50;  $1\frac{1}{2}$  in., \$10.  
 These are a superior axle, and more frequently called for than any others.  
 Do. case-hardened, half-patent, \$7; do. \$8; do. \$8.50.  
 Bands, plated rim, under 3 in., \$1.75; over 3 in., \$2.  
 Do. Mail patent, \$2.50 a \$3.25.  
 Do. galvanized,  $3\frac{1}{2}$  in. and under, \$1; larger, \$1 a \$2.  
 Basket wood imitations, per foot, 88c.  
 When sent by express, \$2 for a lining board to a panel of 12 ft.  
 Bent poles, each \$1.  
 Do. rims, under  $1\frac{1}{2}$  in., \$2 per set; extra hickory, \$2.50.  
 Do. seat rails, 44c. each, or \$4.50 per doz.  
 Do. shafts, per pair, 75c.; bundles, \$4.50; extra, \$5.50.  
 Bows, per set, light, 75c.; heavy, \$1.12.  
 Bolts, Philadelphia, per gross, as per printed list.  
 Do. T, per 100, \$3 a \$3.50.  
 Do. tire, \$1.05 a \$1.80, according to size.  
 Buckram, per yard, 20c.  
 Buckles, per gross, 88c. a \$1.25.  
 Burlap, per yard, 25c.  
 Buttons, japanned, per paper, 15c.; per large gross, \$1.50.  
 Carriage-parts, buggy, carved, \$4.  
 Carpets, Brussels, per yard, \$2; velvet, \$2.75; oil-cloth, 60c. a 80c.  
 Castings, malleable iron, per lb, 12c.  
 Clip-kingbolts, each, 30c.  
 Cloths, body, \$3.75 a \$4.50; lining, \$2.25 a \$3.25. (See *Enameled*.)  
 A Union cloth, made expressly for carriages, and warranted not to fade, can be furnished for \$2 a \$2.25 per yard.  
 Cord, seaming, per lb, 25c.; netting, per yard, 5c.  
 Cotelines, per yard, \$3.50 a \$5.  
 Curtain frames, per dozen, \$1 a \$1.50.  
 Do. rollers, each, 75c. a \$1.  
 Dashes, buggy, \$1.75.  
 Door-handles, stiff, 50c. a 63c.; coach drop, per pair, \$2 a \$3.50.  
 Drugget, felt, \$1.62.  
 Enameled cloth, 5 qrs., 65c.; 50 in., \$1.40.  
 Enameled linen duck, 4 qrs., 55c.; 5 qrs., 75c.; 52 in., 90c. Colored, 15c. higher per yard.  
 Felloe plates, wrought, per lb, all sizes, 15c.  
 Fifth-wheels wrought, \$1.25 a \$1.38.  
 Fringes, festoon, per piece, \$1.75; narrow, per yard, 15c.  
 For a buggy top two pieces are required, and sometimes three.  
 Do. silk bullion, per yard, 35c. a 75c.  
 Do. worsted bullion, 4 in. deep, 35c.  
 Do. worsted carpet, per yard, 6c. a 10c.  
 Frogs, 38c. per pair, or \$1.63 per dozen.  
 Glue, per lb, 25c.  
 Hair, picked, per lb, 50c.  
 Hub-borers (Dole's) for light work, \$15; heavy, \$18 a \$20.  
 Hubs, light, morticed, \$1; unmorticed, 75c.—coach, morticed, \$1.50  
 Japan, per gallon, \$4.50.  
 Knobs, English, \$1.75 a \$2.  
 Laces, broad, silk, per yard, 70c. a 85c.; narrow,  $5\frac{1}{2}$ c.; silk, 8c. a 10c.  
 Do. broad, worsted, per yard, 31c. a  $37\frac{1}{2}$ c.  
 Lamps, coach, \$14 a 18.  
 Lazy-backs, \$9 per doz.  
 Leather, collar, dash, 25c.; slit do., 15c.; enameled top, 25c.; harness, per lb, 45c.; flap, per foot, 15c. a 20c.  
 Linen, heavy, a new article for roofs of coaches, 55c. a 70c. per yard.  
 Moquet,  $1\frac{1}{2}$  yards wide, per yard, \$5.  
 Moss, per bale, 10c.  
 Mouldings, plated, per foot, 12c. a 15c.; lead, door, per piece, 30c.  
 Nails, lining, silver, per paper, 6c.; ivory, per gross, 25c.  
 Name-plates.  
 See advertisement under this head on 3d page of cover.  
 Oils, boiled, per gallon, \$1.50.  
 Paints. We quote white lead, extra, \$3; Eng. pat. black, 25c.  
 Pekin cloth, per yard, \$2.  
 A very good article for inside coach linings.  
 Plushes, per yard, \$2.  
 Pole-crabs, silver, \$5 a \$6; tips, \$1.12.  
 Rubbing stone, per lb, 12c.

Sand paper, per ream, \$3.75.

Screws, gimlet.

Add to manufacturer's printed lists 20 per ct.

Do. ivory headed, per dozen, 38c. per gross, \$4.  
 Scrims (for canvassing), 15c.  
 Seats, buggy, pieced rails, \$1.75; solid rails, \$2.50.  
 Shaft-jacks (M. S. & S.'s), light, \$2.60; heavy, \$2.87. a \$3.25.  
 Do. tips, extra plated, per pair, 31c.  
 Silk, curtain, per yard, \$1 a \$2.25.  
 Slat-irons, wrought, per pair, 55c.  
 Slides, ivory, white and black, per doz., \$6; bone, per doz., \$1.50;  
 No. 18, \$1.75 per doz.  
 Speaking tubes, each, \$4.50.  
 Spindles, seat, per 100, \$1 a \$1.25.  
 Spring-bars, carved, per pair, \$1.  
 Springs, best temp. Swedes, per lb, 24c.; black, 17c.; bright, 18c.;  
 best tempered, 21c.

Two springs for a buggy weigh about 28 lbs. If both 4 plate, 34 to 40 lbs.

Spokes, buggy, per set, \$3.30, or about  $5\frac{1}{2}$ c. each for all under  $1\frac{1}{2}$  in.

For extra hickory the charges are 7c. each.

Steel, Farist &amp; Co.'s Homogeneous American, per lb, 16c.

Do. English Homogeneous, do. 20c.

Do. Compound tire, do. 7c.

Stump-joints, per dozen, \$1.25 a \$1.50.

Tacks, 5c. and upwards per paper.

Tassels, holder, per pair, 63c. a \$1; inside, per dozen, \$3; acorn trigger, per dozen, \$1.25 a \$1.50.

Terry, per yard, \$7.

Top-props, Thos. pat., per set, 35c.; plain, com., 35c.

The patent props, with silver-plated nuts, per set, 87c.

Tufts, ball, per gross, 50c.; common worsted, 12c. a 25c.

Thread, Marshall &amp; Co.'s Machine, No. 432, \$2.40 per half lb; No. 532, \$2.75 do.; No. 632, \$3.50 do.

Turpentine, per gallon, \$3.75.

Twine, tufting, per ball, 35c.

Varnishes (Amer.), crown coach-body, \$5 a \$5.50; hard drying, \$6.50; nonpareil, \$7.

Do. English, \$6.25 in gold, or equivalent in currency on the day of purchase.

Do. American imitation of English, \$7.

Webbing, per piece, 44c.

Whiffle-trees, coach, turned, each, 25c.; per dozen, \$2.50.

Whiffle-tree spring hooks, \$2 per doz.

Whip-sockets, rubber, per dozen, \$7 a \$9; pat. leather, stitched, \$3.

Window lifter plates, per dozen, \$1.50.

Yokes, pole, each, 75c. to \$1.25.

Yoke-tips, 50c. a 75c.

We intend to carefully correct this list monthly, so as to enable those who commission us to make their purchases to ascertain by computation about the amount they require to remit us. This should be done, if a large sum, by draft to our order in New York, or if small, in a registered letter to our address. None but cash orders filled, and where C. O. D. bills are forwarded with the goods by express, charges for collection must be added, which amount in ordinary cases to from 25c. to \$1, according to distances. All this may be saved by sending us the money with the order. Please read notice of "General Business Agency," on 3d page of the cover, in connection with the above.

## TO READERS AND CORRESPONDENTS.

BACK VOLUMES of this work will be sold, in numbers, for \$3; when bound, for \$3.50, to which, if sent by mail, 48 cents must be added to prepay postage; if two or more volumes are called for at one time, they can be had for \$3 each, or will be sent by express, at the purchasers' expense, at the same price. The subscription to the Fifth Volume, now in course of publication, will be (in consequence of the advance in paper and printing) four dollars, IN ADVANCE, for the twelve numbers; and these will be issued, in 1863 for Jan., March, May, July, Sept., Nov., Dec., and afterwards monthly until the close of the volume in May, 1864.

AGENCY.—Our friend Mr. Henry Harper, who is traveling in the West, is authorized to take subscriptions for us, and receipt for moneys paid; and any contract he enters into concerning this Magazine will be honorably carried out by the Publisher. In Canada West, Mr. Robert McKinley, at St. Catharines (dealer in carriage-hardware), will act as our local agent.



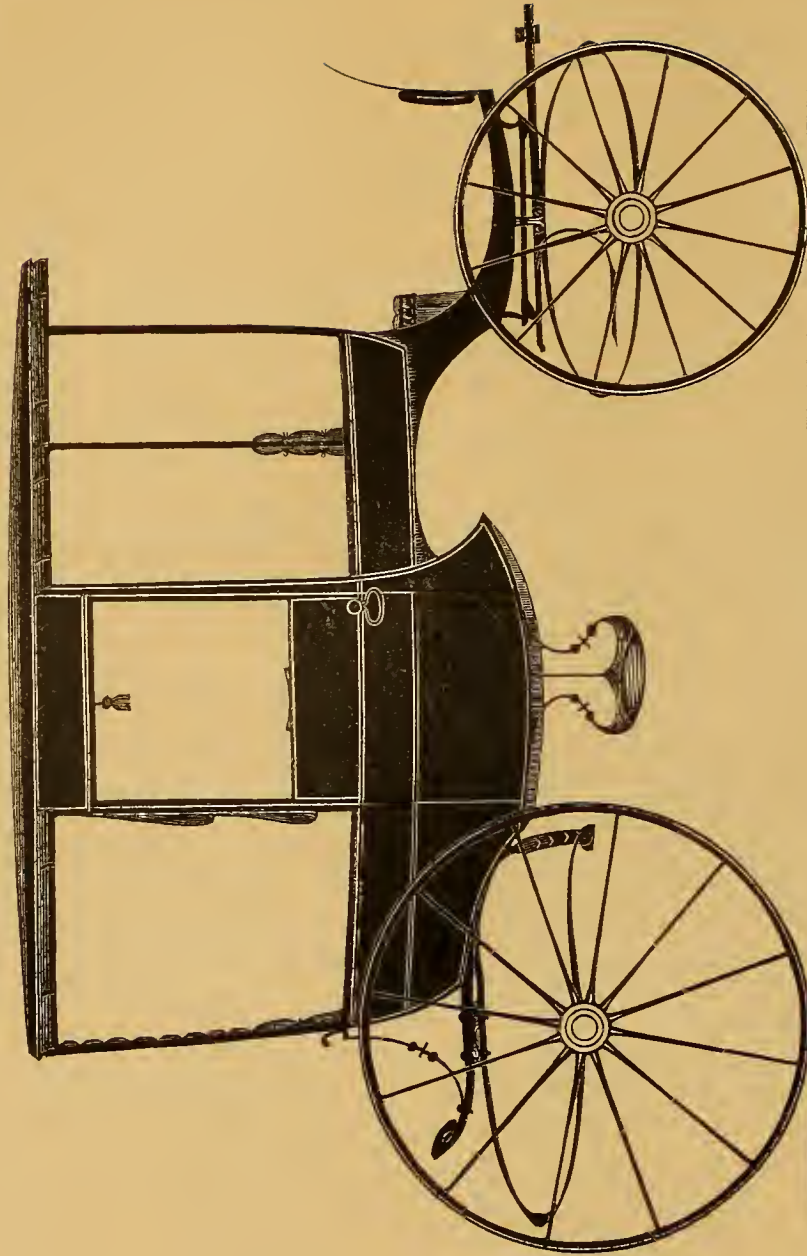

COUPÉ FOR SIX PASSENGERS.— $\frac{1}{2}$  IN. SCALE.

*Designed expressly for the New York Coach-maker's Magazine.*

*Explained on page 104.*



AMERICAN VICTORIA.— $\frac{1}{2}$  IN. SCALE.

*Designed expressly for the New York Coach-maker's Magazine.*

*Explained on page 105.*









THE DECOMEO.— $\frac{1}{2}$  IN. SCALE.

*Engraved expressly for the New York Coach-maker's Magazine.*

*Explained on page 105.*



*Yours fraternally*

*Esra M. Stratton.*

*Engraved expressly for the New York Coach-maker's Magazine.*

**December, 1863.**





DEVOTED TO THE LITERARY, SOCIAL, AND MECHANICAL INTERESTS OF THE CRAFT.

Vol. V.

NEW YORK, DECEMBER, 1863.

No. 7.

## The Coach-Maker's Portrait Gallery.

### EDITORIAL AUTOBIOGRAPHY.

(WITH PORTRAIT.)

It is sufficiently difficult to write the biography of any living subject; but when one undertakes to give his own history, the difficulties increase manifold, as it imposes a heavy tax on his modesty, and may seriously expose him to criticism. In this instance two reasons induce the writer to act as he does—the first is that, during his editorial career, his readers have frequently requested him to give them his portrait, that they might see how he looked; the second, that he is under obligations to give at least one portrait of some coach-maker in each volume, and no other being available at this time, seems to offer an apology for its appearance. The biography accompanying it will be purposely brief.

The writer is the oldest of five children, and came into this troublesome world on the 11th day of May, 1809, at a place known in the locality as Benjamin's Hill, Parish of Green's Farms, Fairfield County, Connecticut. Like many other literary men, he was born in a cottage of humble pretensions; but this cottage was situated on one of the loveliest sites bordering on Long Island Sound. As if by inspiration, Dwight, in his "Greenfield Hill," has truthfully sung the beauties of the prospect from this spot:

"Here, crowned with pines  
 And skirting groves, with creeks and havens fair  
 Embellished, fed with many a beauteous stream,  
 Prince of the waves, and Ocean's favorite child,  
 Far westward fading in confusion blue,  
 And eastward stretched beyond the human ken,  
 And mingled with the sky, there Longa's Sound  
 Glorious expands. All hail! Of waters first  
 In beauties of all kinds; in prospects rich  
 Of bays, and arms, and groves, and little streams,  
 Enchanting capes and isles, and rivers broad,  
 That yield eternal tribute to thy wave!  
 In use supreme: fish of all kinds, all tastes,  
 Scaly or shell'd, with floating nations fill  
 Thy spacious realms; while, o'er thy lucid waves,  
 Unceasing commerce wings her countless sails.  
 \* \* \* \* \* Round yon isles,  
 Where every Triton, every Nereid, borne  
 From eastern climes, would find perpetual home.  
 Were Grecian fables true, what charms intrance

VOL. V.—13

The fascinated eye! where, half withdrawn  
 Beyond yon vivid slope, like blushing maids,  
 They leave the raptur'd gaze. And O, how fair  
 Bright Longa spreads her terminating shore,  
 Commixed with whit'ning cliffs, with groves obscure,  
 Farms shrunk to garden-beds, and forests fallen  
 To little orchards, slow-ascending hills,  
 And dusky vales, and plains! These the pleased eye  
 Relieve, engage, delight; with one unchang'd,  
 Unbounded ocean, wearied, and displeas'd."

Descended from Puritan stock of the fourth generation, he has the satisfaction of knowing that, on the maternal side, his grandfather was the celebrated Capt. Solomon Morehouse, of the Revolutionary Army, and a personal friend of Gen. George Washington, for whose character he entertained a respect bordering on fanaticism. On the paternal side very little can be said, except it be that his grandfather was an honest weaver, anterior to the introduction of machinery into this country for the fabrication of cloths, and that the good cider his cellar contained always brought him plenty of friends. The father of the writer was a farmer, who never rose to any higher public office than that of Lieutenant in the Connecticut Militia; and his only exploit with his sword, as he humorously boasted, was to vanquish a rat who defiantly faced him one evening on the cellar wall. His personal character was such as to challenge the respect of all who knew him, and is well expressed in the reply made by that late eminent lawyer of Westport, Samuel B. Sherwood, Esq., to a skeptic, who said, "I do not believe there is a truly honest man on earth." "Yes, there is," said the squire. "Who is it?" "Eliphalet Stratton," was the quick reply.

The author of Caleb Snug (see page 22, Vol. III.) has already, under an assumed name, given a very good sketch of the life of the Editor, and, among other things, he says that his neck was so weak in his babyhood that, to prevent its breaking, the constant care of a nurse was demanded. "About these days," as the almanacs have it, a circumstance occurred which came near prematurely ending the drama, as far as he was concerned. While sleeping at night another of the rats, with which the cottage appears to have been infested, opened a vein on the bridge of his nose, which at the time proved a serious affair, and the marks of whose teeth can be seen to this day. The only other occurrence to be noted, in this cottage, is the fact that the writer having, when three years of age, climbed up to the second floor, on a flight of stairs devoid of rails,

a misstep precipitated him, head foremost, some ten feet, which, as he remembers, caused an "awful squalling." It may thus be seen that, like Hercules, the writer had his trials before he got into pantaloons.

When about five years of age the writer was sent to the District School, for three months during the Winter and four in the Summer season, until ten years of age; after that, until sixteen, only for short periods during the Winter—his time being required on the farm. Although the writer was very industrious in committing his lessons to memory, and very successful in carrying off prizes, "the rewards of merit," yet he remembers that on one occasion he was induced to play truant with some other boys for one-half day. This act, also, was rewarded with two *lickings*—one, when he went home at night, from his parents, and another the next day, at school, from the master—both of which served to dampen his ambition in that line of business. While very young, he was given to making sketches of any interesting object which came in his way, and these were accompanied by poetical descriptions, which attracted attention from his acquaintances, and received their commendations at the time. His education—if he has any—has mainly been the result of private study, and to accomplish which he may briefly state, without boasting, he has devoted at least six hours of his life daily, for over thirty-five years.

The mechanical life of the writer dates from April, 1824, when he was apprenticed to Charles Townsend, of the firm of Platt & Townsend, of Saugatuck (now Westport), Connecticut. There he spent over five years of his life; with how much *comfort*, the reader may gather from "The Autobiography of Caleb Snug," already published in earlier numbers of this Magazine. Suffice it here to say, that nearness to his parental domicile was a fortunate circumstance for him, as it relieved him from starvation on more than one occasion. Boys who are apprenticed to trades now know nothing of the hardships endured by the former generation of apprentices. May they never experience them!

Having stayed his time out faithfully, the writer soon after removed to New York City, where, after two or three years' labor as a journeyman, he started business on his own account, in 1836, with such success that he has paid his way, and put a little in his pocket for "a rainy day." During these thirty years of city life his pen has not been idle, as numerous publications testify; although up to 1858, when this Magazine commenced, he had no pecuniary interest nor active editorial labor on any. It is true he once allowed his name to appear as an assistant Editor, to give a character to a Western publication, but which he regrets having done to this day—not because he lost pecuniarily by the operation, but that, like Tray in the fable, it turned out that he got into bad company—at least he found out that the stranger to whom he lent his character proved afterwards to be "no better than he should be." When this became known he immediately "cut loose," and started this Magazine; with what success, the public must know already. The acquaintances he has made with some of the best minds in the trade has been very gratifying, and he is happy to number individuals among his regular correspondents who have done much to adorn the literature of their country. It is true, his editorial life has not been all sunshine; some who ought to have stood by him have proved false friends; but, in the main, it has been the happiest portion of his days.

## Mechanical Literature.

### EFFECTS OF WHEEL-CARRIAGES ON ROADS AND HORSES.

BELIEVING that what follows will be of value to our readers, we are induced to reproduce it in our Magazine from the London edition of 1820. This—the first and only edition—is very scarce, and, therefore, of greater interest. Some of its theories experience condemns, and others may be useless to Americans; still, upon the whole, it will be found worthy of perusal. The full title of the book is, "An Essay on the construction of Wheel-carriages, as they affect both the Roads and the Horses; with suggestions relating to the principles on which Tolls ought to be imposed, and a few remarks on the Formation of Roads. By Joseph Storrs Fry. London, 1820."

In the preface the author tells us "the greatest part of the following essay was written in the Winter of 1798-'9, since which time several valuable communications have been made to the public on the subject of wheel-carriages. Still, however, the author of these pages conceives that there are some important considerations connected with this subject that have never been noticed by any other writer; otherwise his manuscript would have remained on the shelf. But, considering that it is a duty we owe to society to endeavor to add to the stock of useful information, he has presumed to submit his thoughts to the public; and he hopes they will meet with candid and impartial investigation from those by whom they may be perused.

The author deems it proper to add that, as it is his wish to render this work an object of interest to persons not conversant with such subjects, he has studiously avoided technical phrases, as well as those that are not in frequent use; but when such necessarily occur, they are generally accompanied with an explanation; on this account, his style may be censured as *too familiar*—a charge he very willingly risks for the sake of obtaining what ought to be the great object of every writer, that of being understood by his readers; and how far he has succeeded they will judge.

FRENCHAY, near Bristol, 6 month 21, 1820.

#### CHAPTER I.

1. On the Mechanical Use of Wheels in lessening Friction. 2. Polished Axles in Oil cause very little resistance to the Horses. 3. Objects which are the principal Causes of Resistance to the Labor of the Horses. 4. Axle-friction, in some cases, very great. 5. Wheels act as Levers in surmounting obstacles, demonstrated. 6. High Wheels advantageous only to a certain extent. 7. Table of Powers equal to the Resistance of Wheels when opposed to certain objects. 8. Power is actually exerted in surmounting an obstacle, as set down in the Table, notwithstanding the velocity of momentum that any carriage may have acquired.

1. THE use of wheels, in lessening friction, is well defined in an essay published in the year 1790, by my friend, Robert Anstice, of Bridgewater. He says, 'A carriage, such as a sledge, sliding over a plane (or road), suffers a friction, or rubbing of its parts against the plane, equal to the distance through which it moves; but, if an axle be applied to it, whose circumference shall be six

inches, and on that wheels be placed, whose circumference shall be eighteen feet, it is evident that, in moving the carriage eighteen feet over the plane, the wheels will make but one revolution; and, as there is no sliding of parts between the plane and the wheels, but a mere change of surface by one part of the latter rising and the other descending nearly perpendicular to the former, no friction will take place there; the whole being transferred to the nave [hub] acting on the axle; which nave, having made but the same one revolution as the outer circumference of the wheel, there has been but a sliding of parts equal to the circumference of the hole in the nave; which, if it fitted the axle, would be but six inches; consequently the friction is lessened as one to thirty-six, besides the advantage gained of confining it to so small a surface, whereby the parts are more easily kept smooth, and fitted to each other, and substances (oil or grease) applied and retained to lessen the remaining friction.' Indeed the difference between drawing a sledge eighteen feet, or even fifteen feet, upon a rough road, and drawing the weight supported by polished steel, sliding upon polished brass, with olive-oil between them, six or even nine inches, is astonishingly great.

2. In the latter case, the friction is so wonderfully reduced as to be scarcely an object of consideration. In what degree it is reduced it would be difficult to determine, even by experiment; as the friction of sledges varies on every variety of road, it is also different in wet weather and dry. I do not, however, think that more than one-hundredth part of the labor of the horses is expended in overcoming the friction of these polished, oiled metals one against another. I insist the more on this point, as it is important to know what causes the resistance which our horses have to overcome, and because I think that the friction of the axles is very much overrated. That it is very highly rated, is evident by the wonderful effects that are announced as produced by such and such patent boxes; as though the labor of the horses were to be reduced in a very considerable degree by the use of them. Those axles and boxes are undoubtedly the best, of which the axles are polished steel, and perfectly cylindrical; and the boxes brass, neatly bored, and well fitted together, with the least *shoulder-friction*, and furnished with a reservoir of oil.

3. The other ninety-nine-hundredths of the power are applied in overcoming all the objects which cause resistance under ordinary circumstances, which would not exist if the outward edges of the wheel were of steel, accurately turned in lathes, and if the carriages moved on surfaces of polished steel, perfectly horizontal, and if all resistance from the atmosphere were removed. These objects consist of—first, the greater inequalities of the roads, which we call hills. Secondly, the lesser inequalities which everywhere present themselves; for even the best roads are not mathematical planes, but a succession of little risings and fallings. Thirdly, the resistance occasioned by the pressure of the wheels in the surface of the road, which is generally *something*, more or less according as the road is more or less hard or soft and more or less clean or dirty, which is commonly a cause of prodigious expenditure of the strength of the horses. Soft materials, dirt, dust, and sand, operate as a perpetual hill against the wheels. I have known a horse with a gig more fatigued by going a few miles on a firm sand sea-beach, when the wheels did not sink more than half an

inch, than he would have been by going three times the distance on a hard road. The fourth cause of resistance is the air, which, to lofty coaches, covered with outside passengers and luggage, is often very great; particularly when they *meet* a strong wind. It frequently happens that when a coach is traveling at the rate of nine miles an hour, it is opposed to a wind going as fast, which forms a resistance equal to a wind going eighteen miles per hour. Therefore, carriages should be so constructed as to meet with as little resistance of this kind as possible.

4. It were, however, absurd to speak of axle-friction in general terms. I have ventured an opinion that, in case of polished axles and brass boxes, with fine oil between them, which should be pure olive-oil, unadulterated with rape-oil, which is of a viscous, glutinous quality, axle-friction is not more than equal to one-hundredth part of the power of the horses. But, in the case of clumsy wooden axles, smeared over with a composition of tar and cow-dung, the friction may be so considerable as to neutralize a fifth, a fourth, or even more, of the strength of the horses; and so in proportion as axles are well or badly constructed, and as the substance interposed may be of a lubricous, or of a viscous and tenacious quality, the axle-friction will be less or greater; or, in other words, in that proportion the wheels will turn round with ease or with difficulty.

5. The action of a wheel as a lever, in overcoming an obstacle, may be demonstrated by the following diagram:

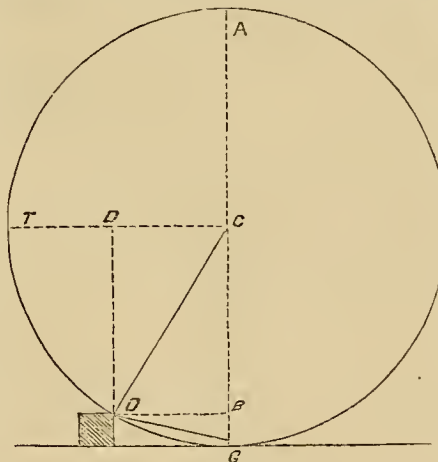

The circle represents a wheel 6 feet in diameter,—C being the center, O an obstacle three inches high, G the ground, T C the line of draft or traction. The lever is represented by the lines C O and O G, of which C O is the arm of the lever, and O G the opposite or lifting end; O being the fulcrum on which the lever turns. In order, how-

ever, to ascertain the power of this lever, we must reduce each member of it to right angles with the lines of their respective directions. This will give us the line D O, at right angles with the line of traction, and the line O B at right angles with the line in the direction of which the weight is to be lifted. Now, the power required to be applied to the line T, to balance 100 pounds at the end of the lever at B, is inversely as the length of the line D O is to that of O B. The length of the line D O is equal to one-half the diameter of the wheel, minus the height of the obstacle, or 33 inches. The line O B, being the mean proportional between the two lines A B, which is 69 inches long, and B G, which is 3 inches long, is 14.3875 inches long. (*Euclid, B. VI., 13.*) The question, then, may be stated thus:

Inches.	Inches.	Pounds.	Pounds.
As 33 :	14.3875 :	100 :	43.589,

or little more than 43 pounds and a half; which is the power, or weight, falling over a single pulley, drawing in the direction T, necessary to balance 100 pounds, on a

wheel 6 feet high, when opposed by a stone, or other obstruction, 3 inches high.

It will be obvious that, as the wheel rises over the stone, the line O D must gradually lengthen; and the line O B must gradually shorten; consequently the resistance occasioned by the stone gradually decreases, until C rises perpendicular to O, when it entirely ceases.

6. It is shown above that a wheel is really a mechanical power, operating as a lever; and this philosophical advantage increases with the increased size of the wheel. But this advantage is more than counterbalanced by a disadvantage which, after a certain period, increases in a much greater ratio than the advantage, which is the weight of the wheel itself. Because, to make a cart wheel 10 feet high, it would be necessary to have the spokes not merely twice as long as for a 5-foot wheel, but they must be twice or thrice the substance, consequently four or six times as heavy; there must also be more of them. The stock of the nave must also be much heavier; the axle much stronger; and the felloes, as well as the tire-iron, must be both much stronger and twice the circumference; therefore, such a pair of wheels, with the axle, would be a load of themselves. In order to convey a tolerably correct idea on this subject, I have calculated what weights, falling over a single pulley, would be equal to the resistance which wheels of different heights, carrying 100 pounds gross weight each, would occasion when opposed by an obstruction 3 inches high, and also by an obstruction of 1½ inch high; the wheel, in each case, being supposed to be in a state of rest.

7. An obstruction three inches high would cause resistance to wheels, carrying 100 pounds gross each, as follows, viz.:

To a wheel 6 feet 0 inches, equal to 43½ pounds.				
5	"	8	"	45
5	"	4	"	46½
5	"	0	"	48½
4	"	8	"	50½
4	"	4	"	52½
4	"	0	"	55
3	"	8	"	58
3	"	4	"	62
3	"	0	"	66
2	"	8	"	71½
2	"	4	"	78½
2	"	0	"	88

An obstruction 1½ inch high would cause resistance to wheels, carrying 100 pounds gross each, as follows, viz.:

To a wheel 6 feet 0 inches, equal to 30 pounds.				
5	"	8	"	30½
5	"	4	"	31½
5	"	0	"	32½
4	"	8	"	34
4	"	4	"	35½
4	"	0	"	37
3	"	8	"	39
3	"	4	"	41
3	"	0	"	43½
2	"	8	"	46½
2	"	4	"	50½
2	"	0	"	55

My object being to make these remarks as plain as possible, I have thought it best in these tables to omit decimal fractions. The result of both evidently is, that the small advantage gained from the use of wheels above 4 feet 6 inches high would not compensate for the inconvenience and increased weight of higher wheels.

It is evident, from the latter table, that the disadvantage of using small wheels does not increase so rapidly as in the former table.

Another circumstance also is to be observed in these tables as important: that, in the latter table, wheels require exactly the same power as those of twice the height in the former table, or in exact proportion as the obstruction is reduced. Hence the necessity of making our roads as smooth and as hard as possible.

8. It may be here proper to meet an objection that may possibly be raised respecting the power which I have stated as necessary to carry a wheel over an obstruction. It may be said that velocity or momentum which a coach may have acquired is sufficient to carry the wheel over the object. Be it so. But the coach does, by going over this object, lose just as much of its momentum as is equal to the power necessary to carry the wheel over the object from a state of rest; and the horses must exert exactly so much additional power to keep up or recover the speed of the coach before their traces will be as slack as they previously were."

### ANCIENT ROMAN CARRIAGES.

BY THE EDITOR.

(Concluded from page 85.)

In our last article mention was made of the *cisium*, a kind of two-wheeled cart, supposed to have been one of the lightest of the Roman traveling vehicles. Some authors maintain that the name of *cisium* is derived from the Latin word *cito*—quick; while others assert that it received the name of *scissum* from the form of the body, being cut through the middle something like our coupés.

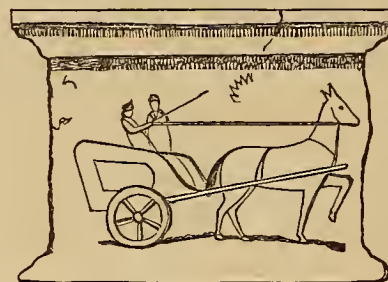

Fig. 7.

The engraving which we annex is supposed to represent the *cisium*, and is copied from a monumental column at Ingel, near Treves, in France. Cicero states that messengers traveled in them fifty-six miles in ten hours—believed to be "quick" time for that day. Ausonius,

in speaking of a three-horse *cisium*, says "it is so light and expeditious that when two only required to travel, the gentry could easily visit their neighbors at their villas in the country." They are said to have had the two wheels much larger than those of any other carriage in use among the Romans. In the speech before the Roman Senate, in defence of Roscio, it is stated that, in ten hours of the night, he flew 56,000 steps in *cisiis*; not only mentioning the speed at which he traveled, but plainly showing that several carriages were employed between different posts; that, no sooner was the traveler landed at one *cisiarii*, or stage office, than the *cisiarius* was ready to forward him to the next without the least delay. The drivers of these vehicles, like many of their successors at the present day, were rather "fast boys," and among the Roman laws are found some severe penalties for their punishment. They were not only reckless drivers, but very negligent towards those who employed them. In traveling at night, as they frequently did, the Roman postillions often upset the *cisium*, by racing with other



vehicles, or in passing them on the road. Having higher wheels than other carriages rendered them more liable to such accidents.

In the time of Julius Cæsar the *cisium* was the post-carriage of the Roman Empire, and was by them introduced into Italy and Gaul by their Roman conquerors. Intercourse was kept up, by means of them, between the chief stations and the military camps—their light construction rendering them very efficient for the purpose. The Romans were noted for making good roads—being made solid, level and dry, and carried forward in a straight line as possible, so as to economize in distance and time. The highest elevations were selected as points for survey, from which the next post or station, often at considerable distance, might be seen.

We learn, from good authority, that in these early times almost every wealthy family had its courier, or messenger, selected generally from their slaves, or dependents, who carried their messages either on horseback or in a *cisium*, so as to be independent of any institution. These couriers had to obtain a license from the government, which allowed them to use the imperial horses and vehicles; for, without special permission from it, no one could, without incurring a penalty, interfere with the business of the *cisiarii*. As a large business was transacted by these *cisiarii*, it involved considerable capital; and, therefore, contractors were selected, of known responsibility and approved business habits, for each station, and bound, under certain rules, to supply vehicles and animals to travelers, and also to carry packages and letters. To protect these from the damaging effects of the weather, they were enclosed in the box of the *cisium*, under the seat.

We are told that the form and general construction of the *cisium* varied. Ordinarily, the body was fixed to the frame or shafts; while, in the better kind, it was suspended on straps or braces, as among us previous to the introduction of springs. Being closed behind, entrance was had from the front; the driver sitting in the front part of the vehicle, except in special cases, when more than two horses were used, when—that the wealthy or aristocratic might not be disgraced by sitting beside a menial—the driver was mounted on a third horse, all abreast, holding the pole-horses by reins. The wealthy Romans were not indifferent to comfort in the use of their carriages, so they had them provided with cushions; but it does not appear that the *cisiums* were ever used by the Roman ladies. They were too open and exposed for the gentler sex; and, no doubt, prejudice had much to do in discountenancing the practice, as the *cisium* was known as “the gallant’s carriage.” The young and gay Romans frequently employed them in their nocturnal expeditions, disguising themselves by putting on a *cucullus*, or cap similar to that worn by the driver. Cicero, in speaking of Marc Antony, the victim of Cleopatra’s charms, says that “he drank until evening, and then drove quickly in a *cisium* to the city with his head covered,” that he might not be recognized by the public.

A carriage, supposed to represent different varieties of the *cisium*, is found on antique gems, illustrative of ancient mythology—the form, doubtless, being selected to represent speed—to which two horses are generally attached; these, to so light a carriage, being quite sufficient; although Ausonius tells us the wealthy often had three and four harnessed up, not because such were absolutely necessary to draw it, but for the sake of show.

The chief uses to which chariots were put among the Romans were of the domestic kind—in the chariot race, and to grace the triumphal procession of some victorious general, consul, or prætor. Plutarch, in his life of Paulus Æmilius, gives us an account of a triumphal procession, decreed him by the Roman senate, in honor of his victory over Perseus, king of Macedon, from which we take the following account, illustrative of the victor’s chariot here given:



Fig. 8.

“In every theatre, or, as they call it, *circus*, where equestrian games used to be held, in the *forum*, and other parts of the city, which were convenient for seeing the procession, the people erected scaffolds, and on the day of the triumph were all dressed in white. The temples were set open, adorned with garlands, and smoking with incense. Many *lictors*, and other officers, compelled the disorderly crowd to make way and opened a clear passage. The triumph took up three days. On the first, which was scarcely sufficient for the show, were exhibited the images, paintings, and colossal statues taken from the enemy, and now carried in two hundred and fifty chariots. Next day, the richest and most beautiful of the Macedonian arms were brought up in a great number of wagons. These glittered with new furbished brass and polished steel; and though they were piled with art and judgment, yet seemed to be thrown together promiscuously—helmets being placed upon shields, breast-plates upon greaves, Cretan targets, Thracian bucklers, and quivers of arrows huddled among the horses’ bits, with the points of naked swords and long pikes appearing through every side. All these arms were tied together with such a just liberty, that room was left for them to clatter as they were drawn along; and the clank of them was so harsh and terrible that they were not seen without dread, though among the spoils of the conquered. After the carriages loaded with arms, walked three thousand men, who carried the silver money in seven hundred and fifty vessels, each of which contained three talents and was borne by four men. Others brought bowls, horns and goblets, and cups all of silver, disposed in such order as would make the best show, and valuable, not only for their size, but the depth of the basso-relievo. On the third day, early in the morning, first came up the trumpets—not with such airs as are used in a procession of solemnity, but with such as the Romans sound when they animate their troops to the charge. These were followed by a hundred and twenty fat oxen, with their horns gilded, and set off with ribbons and garlands. The young men that led these victims were girded with belts of curious workmanship; and after them came the boys who carried the gold and silver vessels for the sacrifice. Next went the persons that carried the gold coin in vessels which held three talents each, like those that contained the silver, and which were to the number of seventy-seven. Then followed those that bore the sacred bowl, of ten talents’ weight, which Æmilius had caused to be made of gold, and adorned with precious stones; and those that exposed to view the cups of

Antigonus of Selencus, and such as were of the make of the famous artist, Thericles, together with the gold plate that had been used at Perseus' table. Immediately after was to be seen the chariot of that prince, with his armor upon it, and his diadem upon that; at a little distance his children were led captive, attended by a great number of governors, masters and preceptors, all in tears, who stretched out their hands, by way of supplication, to the spectators, and taught the children to do the same. There were two sons and one daughter, all so young that they were not much affected with the greatness of their misfortunes. This insensibility of theirs made the change of their condition more pitiable, insomuch that Perseus passed on almost without notice, so fixed were the eyes of the Romans upon the children, from pity of their fate; and many of them shed tears, and none tasted the joy of the triumph, without a mixture of pain, till they were gone by. Behind the children and their train walked Perseus himself, clad all in black, and wearing sandals of the fashion of his country. He had the appearance of a man that was overwhelmed with terror, and whose reason was almost staggered with the weight of his misfortunes. He was followed by a great number of friends and favorites, whose countenances were oppressed with sorrow; and who, by fixing their weeping eyes continually upon their prince, testified to the spectators that it was his lot which they lamented, and that they were regardless of their own. He had sent, indeed, to Æmilius, to desire that he might be excused from being led in triumph, and being made a public spectacle. But Æmilius, despising his cowardice and attachment to life, by way of derision, it seems, sent, by word, 'That it had been in his power to prevent it, and still was, if he were so disposed;' hinting that he should prefer death to disgrace. But he had not the courage to strike the blow; and, the vigor of his mind being destroyed by vain hopes, he became a part of his own spoils. Next, were carried four hundred coronets of gold which the cities had sent Æmilius, along with their embassies, as compliments on his victory. Then came the consul himself, riding in a magnificent chariot—a man, exclusive of the pomp of power, worthy to be seen and admired; but his good mien was now set off with a purple robe interwoven with gold, and he held a branch of laurel in his right hand. The whole army likewise carried boughs of laurel, and, divided into bands and companies, followed the general's chariot; some singing satirical songs usual on such occasions, and some chanting odes of victory, and the glorious exploits of Æmilius, who was revered and admired by all, and whom no good man could envy."

Plutarch also tells us that Camillus, who was greatly elated with a victory over a rival city, "after a siege of ten years, misled by his flatterers, took upon him too much state for a magistrate subject to the laws and usages of his country; for his triumph was conducted with excessive pomp, and he rode through Rome in a chariot drawn by four white horses, which no general ever did before or after him. Indeed, this sort of carriage is esteemed sacred, and is appropriated to the king and father of the gods."

We shall, in future numbers, present the reader with sketches and illustrations of some drawings, found in the exhumed ruins of Pompeii, that will serve to still further show the state of carriage-making among the ancient Romans, of which Pompeii was a dependency.

#### WHAT BECOMES OF THE COACHES?

DICKENS, the popular English writer, in one of his recent sketches, takes his reader to the streets of a dilapidated place, that once "had been a great stage-coaching town, in the great stage-coaching times," before railroads killed and buried all the coaches. He tells us that, walking along the streets, he came to a coach-maker's workshop, and began to look about him with a revived spirit, thinking that perchance he might there find some remains of the old times of the town's greatness. There was only one man at work—a dry man, grizzled, and far advanced in years, but tall and upright—who, becoming aware of his looking on, straightened his back, pushed up his spectacles against his brown paper cap, and appeared inclined to defy him, to whom (says Dickens) I pacifically said:

"Good day, sir!"

"What?" said he.

"Good day, sir!"

He seemed to consider about that, and not to agree with me.

"Was you looking for anything?" he then added, in a pointed manner.

"I was wondering whether there happened to be any fragment of an old stage-coach here."

"Is that all?"

"That's all."

"No, there ain't."

It was my turn now to say "oh," and I said it. Not another word did the dry and grizzled coach-maker say, but bent to his work again. In the coach-making days, the coach-painters had tried their brushes on a post beside him; and quite a calendar of departed glories was to be read upon it, in blue, and yellow, and red, and green, some inches thick. Presently he looked up again.

"You seem to have a deal of time on your hands," was his querulous remark.

I admitted the fact.

"I think it's a pity you was not brought up to something," said he. I said I thought so, too.

Appearing to be informed with an idea, he laid down his plane (for it was a plane he was at work with), pushed up his spectacles again, and came to the door.

"Would a po-shay [post-chaise] do for you?" he asked.

"I am not sure that I understand what you mean."

"Would a po-shay," said the coach-maker, standing close before me, and folding his arms in the manner of a cross-examining counsel—"would a po-shay meet the views you have expressed? Yes, or no?"

"Yes."

"Then you keep straight along down there till you see one. You'll see one if you go fur enough."

With that, he turned me by the shoulder in the direction I was to take, and went in and resumed his work against a back-ground of leaves and grapes,—for, although he was a rude man, and discontented [what coach-maker is not discontented?], his workshop was that agreeable mixture of town and country, street and garden, which is often to be seen in a small English town.

ADVANCE IN PRICE.—A leading house in this city has raised the price of first-class top buggies to \$340. In view of the costs incurred in the production, this is not too great a sum for them now.

## Home Circle.

LOTTIE HILL.

BY LUA DELINN.

(Continued from page 87.)

"ADAM was farther advanced than any one else in the school. Indeed, there was nothing more that the instructors employed in Tompkinsville—and they'd had some pretty good ones—could teach him. Mr. Arnott intended that Adam should carry on the farm, a very fine one, and was afraid he'd have notions above it if he got any more learning! He knew enough already for all practical purposes. But Adam was constitutionally opposed to all kinds of manual labor—people called him lazy. He had a passion for study, and was determined to gratify it at any cost, though he should first have to wait weary months—it might be years. He had really manifested an interest in my progress and my plans that won for him my best feelings, feelings so deep and tender that in their birth I seemed to awake to a higher, nobler life, even while apparently plodding along on the same old level. He had conferred favors on me; that is, he had given me his protection, and he had been my teacher; this won for me his kind feelings, which, blending with a sort of pity for my dreary life, and an active sympathy in my plans and hopes, made him imagine that he, a boy (a little past sixteen), had learned the lesson of love, as even manhood seldom learns it. I, ignorant of any process of analysis, was easily deceived and gave myself up to the beautiful illusion. Nor do I regret it now as I look back upon the utter desolation that followed the wreck of hopes which had been life to me. Are you thinking of Adam Arnott, and trying to sketch a picture that shall be suited to the uncouth figure Lottie Hill presented when you first saw her? Let me spare you the trouble. To give you a general idea in few words, I will say that even my uncultivated, and, of course, partial eyes, could see nothing in his ungainly figure to admire. He was as much overgrown as I was dwarfish. He always showed a painful consciousness of hands and feet—which were broad, like his father's acres. His great head was surmounted by a heavy shock of short, coarse hair, the color of which suggested a blighted carrot. A high, broad, full forehead jutted far out over little blue eyes that were dull and cold, while the other features were at rest, but whose brilliancy was all the more enhanced, for their being so deeply set, whenever the lips performed their office. The nose—ah, that was something to talk about, if prominence of position gives features, like individuals, a claim on public attention. The mouth was very large, but that was never noticed because the nose so far exceeded it in size. It closed with a snap, pressing the thin lips firmly together. His large, square chin was unrelieved by the slightest dimple, and the shock of pale hair did not even cast a shadow over ears that, so far as size was concerned, might have passed for *plantain* leaves. Just as I describe him now, just so he looked to me in those days when the enthusiasm of youth and love made me regard his *spiritual* individuality as the perfection of beauty. Just as Adam had determined to have an understanding with his father at all hazards, Mr. Arnott suddenly died. The management of the farm necessarily

devolved upon Adam, and, the accomplishment of his plans, not given up, was indefinitely postponed. It was hard for the boy, but he went to work with the stern purpose of a man. We seldom met now, and when we did it was but for a brief moment, yet the warm clinging clasp of our hands seemed to render them stronger, or their burden of labor lighter, and the loving, lingering look into each other's eyes filled them with brightness whose glory shone out upon our separate paths till they met and diverged again.

"In this way a year passed, and then Adam was left alone, free to pursue his own course. That loathsome disease, small-pox, broke out in the village, and Mrs. Arnott was one of its first victims. She had never shown me any kindness except in refusing to increase my labors by any part of her own; but that, as I have intimated, was less a kindness than it might seem. A word of encouragement from her now and then would have done me a world of good, yet she had never spoken it. She evidently regarded me as doing well in my proper sphere, fulfilling the only destiny that poor white trash could ever aspire to. But she was *Adam's mother*, and I could not suffer her to be neglected. None of those little attentions which neighbors usually show each other in times of sickness or trouble were offered now. Adam and I watched with and waited on her eight days and nights, and then I prepared her body for burial, and we two followed her to the grave. I think Adam felt less of sorrow than relief, for when we came to the lane that turned off toward Squire Tompkins's (I was going there, for two or three of the family had the epidemic) he said, in a light, cheerful tone, 'Well, Lottie, I know of a man who wants to buy my farm, and I shall soon strike a bargain. It will not be long now till I am in one of the best schools in the East, and once there, I shall soon fit myself to enter college.' My mind was instantly made up. I *couldn't* stay in Tompkinsville when Adam was gone, so, when he should leave, I would go with him as far as the city. I had seen, the day before, in a city paper (that was one of Adam's innovations), an advertisement for a country girl to do general housework. A liberal salary was offered. I spoke of it to Adam. He answered it for me, and in a few days I received a note, saying that I might come on trial, and if faithful and efficient, I would receive two dollars per week. This was more than I had ever thought of in my most sanguine moments. It gave me enlarged ideas of the labor I should have to perform, but that didn't daunt me in the least. I *looked beyond*. There was great gossiping in the village over the announcement that I was going to the city to work for wages. No one was informed of my *ultimate* plans. Nearly every head was shaken ominously, and every tongue was loosed to foretell the inevitable ruin that awaited me. I was charged with ingratitude toward all Tompkinsville, for hadn't everybody given me a home all these years. However, none of these things moved me from my purpose, and one Monday morning I found myself and Adam jolting along in a rough wagon over a rough road, on our way to the railroad station, some five miles distant. We reached it in a marvelously short time, I thought; but when we took the cars, and were whirled along at the best speed of the 'lightning train,' over the forty miles that lay between us and the city, I wasn't conscious of a single thought—even my breath seemed, for the time, suspended. Walking up from the

depot, Adam carrying the little bundle that contained all my worldly possessions, we were fit subjects for a comic sketch. He had called to his aid the utmost skill of our village tailor to fit the outward man for the new life upon which he was about to enter, but my eyes, all unpracticed as they were, noticed a great difference between the prevailing style in Tompkinsville and the city mode, both in cut and color. Men don't notice such things so quickly as we women do, and he remained happily ignorant of the fact that his new suit was odd enough to provoke smiles on the dirty face of every urchin we met. But it was not the oddity of the new clothes, after all, so much as it was his uneasy consciousness of the fact that they were new. For myself, I had nothing new to embarrass me. The dress I had on was my best, but it was one of Mrs. Tompkins's old ones that I had long ago made over. Its narrow skirt fell in straight lines about my limbs, in striking contrast to the full, flowing, graceful drapery of every woman and little girl I saw. My sun-bonnet was originally a bright-colored calico one, but 'all that's bright must fade,' and my bonnet had proved no exception, but in the earliest moments of its usefulness it faded out nearly white, and I had colored it with *peach leaves*. We blundered along over the smooth pavement as we had been accustomed to stumble over the rough clods of the country roads. Our first business was to find a daguerreian gallery, for Adam wanted to take my likeness with him, and leave one of himself for me. The operator must have had an eye for the ludicrous. He took our pictures *at full length*. I had no jewelry, so he gave my sun-bonnet, which I held by the strings, the benefit of his coloring. Those were *specimen-pictures*. I afterwards saw copies of them displayed in his show-case. From there Adam went with me to find the dwelling where I was to begin my new career. After frequent inquiries, and many steps taken uselessly, we paused on the steps of a mansion grander than anything I had ever seen or imagined. Here, on the marble steps, regardless of passers-by, we exchanged the first and last kiss, and said good-by. My new duties proved lighter and fewer than I had anticipated, though they were sufficient to keep nearly all my time employed. The cook laughed at my greenness, but, though not kind, she was not ill-natured, and seeing my anxiety to improve, would sometimes explain things to me that I should have been slow to learn by myself. She was glad of all the assistance she could get, and I was glad to help her all I could, that I might have a chance to become an accomplished cook, and thus increase my wages. No one understood the business better than she; and I, as usual, was quick to learn. I did not care to go out often, and on several occasions allowed her to go in my place, while I performed her duties. That I performed them acceptably, was evident from the fact that her absence was not suspected. I retained my place a year, then engaged with another family, as cook, at greatly advanced wages. I cared little for my personal appearance, or rather, I was unwilling to spend time or money in making any improvement in it. My dress cost me almost nothing. I hoarded up my money with a miser's care. All the first year, Adam's letters had come weekly; the second, they fell off until I doubtfully looked for them monthly. My heart made excuses for him—he was a close student, and had little time for writing. The third, and last year of my servitude, was near its close, and for three months I had been

waiting anxiously to hear from him, impatient to tell him of my success—fearing that intense application to study had made him ill—when I received a package and a letter. Wondering what the former could be, I opened it first, and there was my picture and one of himself, in which he seemed to be illustrating the generally received idea of a sophomore—foppish and conceited! I turned from it as from an impostor, back to the green, gawky figure with its simple honest face, that faithfully represented Adam as he used to be. Pausing awhile to study the contrast, I sadly felt that the change was greater in the inner than in the outer man; but I was utterly unprepared for the contents of the letter. He had sent me 'what he flattered himself was a first-rate likeness of him, presuming that, without reference to our boy and girl attachment, which, no doubt, was as great a source of amusement to me as it was to him, I would like to keep it as that of an old friend. He would trouble me to return the first—a miserable thing which he wanted to destroy.' Mine, too, must be a caricature. He 'would really like a good one' of me, but feared 'it would be asking too much; it might not be convenient for me to send one at present.' He hoped I was enjoying myself. Thought I seemed to have given up the idea of going to school. Perhaps it was as well, for how could I, in the kitchen, earn the means of defraying expenses at a good school long enough to accomplish anything. It had been one of the romantic notions of my early girlhood. For himself, he was progressing rapidly; had the post of honor in his class. When he left college he would immediately devote himself to the study of the law. He closed by subscribing himself my sincere friend and well-wisher, *Adams Arnott*. Ashamed of the old-fashioned name his mother gave him, he had modified it so as to give it quite an aristocratic sound. The first thing I did was to seal up the semblance of the stranger's face and direct it to *Adams Arnott, Esq.*; the next was to pen a few lines which might accompany it. I told him that, although I had no doubt it was a fine likeness of him now, yet it was not in any respect characteristic of the Adam so truthfully represented in the old picture. I would, therefore, retain the latter. I was glad he had sent mine. Had wanted a good likeness of myself before I should begin to look old and faded (reminded him that hard work made one fade early), but couldn't well afford it, and this, being still a true copy of the original, would answer every purpose. I was still doing kitchen-work, and received pretty good wages—enough to keep me comfortable; enjoyed myself much better in the city than I had in Tompkinsville. As for studying, I hadn't done much of that in the last three years.

(To be concluded next month.)

## Pen Illustrations of the Drafts.

COUPÉ FOR SIX PASSENGERS.

Illustrated on Plate XXV.

FOR a family carriage, in many instances, six seats are indispensable, and, to provide them, a great variety of vehicles have been introduced; but we think we are the first to originate a six-passenger coupé. With this simple announcement we leave the design for the inspection

of our subscribers, believing that it will find favor with them, and introduce itself. X. Z.

AMERICAN VICTORIA.

*Illustrated on Plate XXVI.*

VICTORIAS are very fashionable among us at present, and well they may be. They possess many advantages over all others for Summer carriages of light draught. The design we give emanates from this office, and is intended for either one or two horses. It has been drawn by one of our special artists expressly for this Magazine.

THE DECOMEO.

*Illustrated on Plate XXVII.*

WE give this as one of the latest styles of the coal-box. As may be seen, it has a concave recess in the side to give greater facilities in turning. The toe-board, too, is essentially different from anything heretofore given in this Magazine. It has a singular name, but we are not answerable for that.

## Sparks from the Anvil.

### POLE AND YOKE FOR A LIGHT BUGGY.

WE give this pole and yoke for the sake of convenience, not because we think others may not be as well posted as ourselves in all that pertains to making them



correctly. It will be found *convenient* to have the dimensions on paper, since memory is frequently defective and cannot be relied on. Premising that in some instances the length of the horses to be used will vary the length of the pole, we give the following as general dimensions:

The entire length of the pole, from the central bolt of the double whiffle-tree bar to the end of the pole socket, is 9 feet. At the double whiffle-tree bolt the pole is  $1\frac{5}{8} \times 2$  in. The double whiffle-tree at this point is of the same size, and at the ends  $1\frac{1}{4} \times 1\frac{5}{8}$  in. The single whiffle-trees are 2 ft. 10 in. long, and  $1\frac{1}{4} \times 1\frac{5}{8}$  at centers. The whiffle-tree tips must regulate the ends—say in this instance 1 in. The pole bar is  $\frac{3}{4}$  in. square before finishing. One important matter—too often neglected—should be taken into consideration: that is, to have the whiffle-trees work as near as possible, without subjecting them to the rub of the wheels. With this in mind, it is evident that the height of the front wheels must determine the length of the pole, sweep of the bar—in a word, all back of the whiffle-trees; for, it is a well settled fact, that the nearer

horses can be harnessed to the front of the carriage, the more easily they will draw it.

The stays to the pole and bar are from  $\frac{5}{8}$  oval iron. The plate under side of the bar is  $\frac{5}{8}$  half oval, and attached with a T to the pole, and extends at least 12 inches in front of the double whiffle-tree bolt.

Yokes, in this market, are ready turned to hand (see price current); but we give dimensions for others who are obliged to get them turned as wanted. In the center  $1\frac{1}{2}$  in. diameter; the tips 1 in. over all. Beads should be raised  $2\frac{1}{2}$  in. apart at the center of this yoke, to prevent the leather receiving the end of the pole from slipping—now generally substituted in place of the old ring and staple, as it is less liable to rattle. The wood-work of this entire job is best made of hickory.

### TUYERE-IRONS.

THE London *Engineer* lately gave an illustration and description of a tuyere-iron patented by one Henry Lee Corlett, of Inchicore, Dublin, which has called out several correspondents who all testify that the same is a plagiarism, just as many of the so-called inventions relating to carriage-making, taken out in this country, are known to be. T. Frost, of the Canal-street Iron Works, Derby, says that "nine years ago he made a working drawing of the same, and had them made and put in use, not only with one, as shown in the *Engineer*, but also with three,

tuyeres for heating large masses of iron, say 20 inches in diameter, or more, with exactly the same valve arrangement for supplying or cutting off the blast." Another writer says, that a tuyere, identically the same, was invented about eight years ago by Geo. Stephenson, now of the St. Nicholas Works, Thetford, and was, he believes, tried by him, although it was never patent-

ed or generally adopted, and that he made tracings, for his own use, from Mr. Stephenson's drawings. We think that some improvement should be adopted in our patent-office whereby the public may be protected against fraud from unprincipled adventurers, or else it will come to be considered as merely the initiatory school for public robbery.

PROBABLE RISE IN IRON.—We would advise our friends who are in a condition to study economy, to lay in the stock of iron they may need during the coming six months. The present indications are that the demand for iron required for the building of iron-clad vessels ordered by our Government, and the high wages now demanded by operatives, will all tend to increase the price.

## Paint Boom.

### COMPOSITION OF PAINTS.

BY H. HARPER.

(Continued from Page 75.)

Preparation of dryers—Boiled oil injurious to paints—Some dryers curdle the paint—Expansion and contraction of paint—Reasons why paints cleave off in certain cases—Turpentine not a dryer—The writer opines that turpentine has had its day; that it is injurious to the painter.

RED-LEAD and litharge—both oxyds of lead—are used in boiled oil for dryers, in quantities varying from four to eight ounces to one gallon of oil. After the dryer is mixed with the oil, it should be heated over a steady fire until it makes a sharp snapping or sputtering noise when the most trifling particle of water is dropped into it. The painter who has been accustomed to boiling oil, knows when it is heated to a sufficient degree by the peculiar color that it assumes.

Boiled oil should not be mixed with paint, as a general thing, if it can be avoided. The heating of oil injures it in different ways. Red-lead, or litharge, when mixed with raw oil, is a sufficient dryer of itself; but, there are cases where our great haste to complete a job induces us to sacrifice durability to present appearances; therefore, we add some other dryer to hasten it. "The world is still deceived with ornament." It is much better to mix paint in raw oil, and add enough dryer to make it dry at the required time. By so doing you avoid the danger to the paint from cracking after it has dried, providing it has sufficient time to dry before a second coat is applied. It will last longer, and it is just as convenient to use raw oil. For a dryer, drying japan may be used for body coats, in quantities equal to one-third of the oil. Less, as a general thing, would be safer, particularly if the paint is a dryer of itself. Sugar-of-lead can be ground fine, and used as a dryer to raw oil; and it is an excellent, good dryer. It may be used in quantities varying from one-half to three ounces to one pound of paint. White vitriol may be used in the same way, or both together—enough to make the above quantity. There are many kinds of dryers, mostly prepared from sugar-of-lead and white vitriol, which would be useful and handy to use, providing we could know the exact quantity we are using of the real dryer; but it is so much adulterated, that it is hard to tell how much we are using, and unsafe on work that requires exactness. Dryers of this kind, when used in large quantities, have a tendency to change the color of the paint to a yellowish, or brown tinge, which imparts to delicate colors a bad look after they have become dry. For that reason discretion should be used about the quantity in such kinds of colors. The dryer used in the oil for varnish sometimes changes the color of the varnish to a dingy yellow. Aside from the bad look which is given, either to paint or varnish, it also destroys the lasting qualities of both. This yellowish color is the oxyd of the oil which the dryer eats up—if we may so call it—the same oxygen eating up iron.

Large quantities of dryers have the effect to curdle the paint, so that it cannot be used with a pencil-brush on either striping or other kinds of ornamenting. Extreme caution and good judgment should be used in these

matters, so as to always have paint in the best condition for use—particularly so in this fast age, when painters are required to perform impossibilities by making a good job in an insufficient space of time.

The different coats of paint should have an uniformity of dryer in them. If any deviation is made from this rule, the last coat should have the least dryer. When this is not done, the paint will break loose from the different coats, and come off in scales. The reason for its doing so is the difference that the two kinds of paints have in expanding or contracting. For instance, heat will expand iron and contract wood. Should wood and iron be made to adhere together by means of glue, or any brittle adhesive substance, the moment that the temperature was raised in them by heat, they would break apart by the expansive quality of the one, and the contracting quality of the other. The division would be exactly where the nature of the two articles differed. The same reasoning applies to paints which have different powers of expansion or contraction. How often we are shown paint that has cleared off from another coat—perhaps down to the priming coat—and are asked the reason for its doing so. How often the answer has been made that "it is because too much japan has been used in the paint." Now, this is not a very satisfactory answer, even to ourselves; neither is it a true one. If paint is mixed entirely with japan, and a number of coats put on to wood, giving them sufficient time to dry, they will not cleave off in scales, because the expansion or contraction of the different coats are alike. It is true that if the wood becomes saturated with water and expands more than the paint—as it naturally would—they will have to separate; but the different coats of paint will cling together in a solid mass, that would require an immense power to separate, in the way the expansive force separates them.

Painters frequently find their paint cleaves off, and they cannot account for it, because they have used in certain cases more japan, and yet not had any difficulty. The reason for this difference is in the body-coats that have been previously put on. We do not mean to say that the priming coat should be mixed with the same quantity of oil that the other coats are; because the wood absorbs a part of the oil of the first coat, which would make the subsequent ones unequal.

We have noticed in cold climates, where paint was applied to brick, that, in all places where it was exposed to dampness, the frost would break out a piece of the brick just as far as it had absorbed the oil. The reason for it was exactly the same that we have given for paint when scaling off. The part of the brick that had not absorbed oil became slightly saturated with water. Frost would expand the water, but not the oil; therefore, where the two met, a break could not be avoided. Those who wish to paint on brick will do well to guard against such mishaps.

Turpentine and its substitutes have been erroneously considered dryers. Turpentine is so far from it, that paint will not dry while there is any of the article in it. All that it helps paint in drying, is, that it evaporates with and leaves less oil to dry. The substitute we are now using for turpentine is of such recent date that we are not now prepared to decide exactly as to its comparative merit with turpentine. Yet we are satisfied that opinions have been given too hastily by painters on this subject, and we shall be disappointed if turpentine is ever

extensively used again, either in paint or varnish, as formerly.

We do not know exactly what to call the new article, as it has so many different names, received at every stage of improvement that has been made on it. The last named, and the best article that we know of, is "Valentine Spirits;" for, if we set entirely aside our old prejudices, we shall be at a loss to choose between it and turpentine as an article to be used in paint. Two years more of improvement will leave turpentine as far in the background as it has some other portion of Secessia's staple articles. One thing that should have long ago condemned turpentine is the fact that it has a peculiarly enervating effect on the painter. The new article is free from that effect. Every painter should be awake to this subject, and, when the time comes that he must choose between the two articles, he should be prepared to make a judicious choice.

(To be continued.)

## Trimming Room.

### ORIGIN OF THE WORD "HAMMER-CLOTH."

THE derivation of this word has been the subject of more disputes between etymologists than any other out of Shakspeare's works; and yet its meaning seems to us as clear as day. But first, as to the opinions opposed to our own. One authority maintains that hammer-cloth is literally the old original word, and because it was used to cover the hammer, without which no journey was made in the olden times, as repairs might be required. Now, can there be any more absurd supposition? Imagine the immense hammer-cloth being brought into use to cover a hammer! It reminds one of the mountain in labor, and the ultimate birth of a mouse, small even for a mouse, or, to be more homely, it is as though we called a scullery a salt-box, because a few teaspoonfuls of salt were in the usual receptacle. And yet the authority from whom we have quoted has *his* authority, whereby he substantiates his belief. He says, "In an old family coach, which is still preserved at Bean Manor Park, Leicestershire, and is 120 years old, is a budget, or stout leathern bag lining, under the coachman's seat, to contain a hammer, a pair of pincers, a cold-chisel, 24 clouts, 12 lynch-pins and hurtees, and 200 clout-nails, as specified in the estimate for building the coach. This forms," continues the authority, "a curious illustration of a fact which is very well known, that the bad roads of the last century made it important that, in traveling, the coachman should have a hammer and other necessary implements for the repairs required after an occasional break-down. The hammer-cloth which once covered the receptacle for those tools still preserves its name in memory of the practice, though now used only for ornament or display. The above-mentioned coach was built in London, by Edward Harlee, in 1740, for William Henich, Esq., of Bean Manor, whose arms, impaled with those of Gage, his wife, are still painted on its panels. Mr. Henich, as Sheriff of Leicestershire, in 1743, rode in this carriage to meet the judges, and probably he continued to use the carriage until his death, in 1773, at the age of 84."

The estimate, which is preserved, shows the coach, with harness for four horses, and extras, to have cost

£92 5s. "It would be difficult," says our authority, in conclusion, "to find elsewhere in England a family carriage of the reign of George II. still in good preservation."

Another etymologist says, "Hammer-cloth is a corruption of armor-cloth, because, in former times, and not unfrequently now, the cloth in question has affixed to it, or woven into it, the arms of the family to which the carriage belongs."

Dr. Pegge says hammer-cloth signifies a box covering, and refers to a box in which things were carried. Richardson, in his dictionary, accepts this derivation; and it certainly is far nearer the truth than the wild supposition of its referring to a hammer, or *hammerial* bearings. However, the cream of the derivations is to be found in a publication called "Norfolk Works." "The hammer-cloth means the skin-cloth, and it was usually of bearskin. [See an example in Felton's work.] The Icelandic *hamr* is skin, or covering, connected with the term to *hapup*, and also with *hamus* (the encircling hook), and ham-horne."

Does this not out-herod Herod? It was bad enough to suppose that hammer-cloth meant a hammer-covering. This was simply a stupid way of answering the query. To suppose it referred to armorial bearings was ingenious, if the suggester has had little respect for our ancestors in supposing they could spell armor with the letter H. But what shall we say of the learned blockhead who would try to persuade us that an adjunct of that coach, which originally came from the South of Europe, should be known by a name founded on a word belonging to the Icelander—in the extreme North of Europe? This derivation is simply that of an impertinent man, who likes to mystify a plain fact, in order to flatter his own vanity.

Why, the derivation is as clear as a noon-day sun in August. It is *hamper-cloth*. The corruption hammer-cloth is exceedingly natural, and follows the rule of words in corruption—this being, that the corrupted sound is always less difficult than the real. P after M is very difficult in pronunciation, as the reader can prove by experimenting with the next child.

As to the likelihood of a hamper-cloth being wanted, let it be remembered that a coach, 200 years ago, took many days to achieve a journey to London. A journey of many days necessitated food during the transit, and, as country inns were not always prepared for guests, we can readily comprehend that the traveler would carry his own *hamper*; and, as a hamper is not a slightly object, we can easily comprehend that it would be covered with an elegant cloth. Is not this derivation self-evident? Does it require any consideration? Is there any need for doubt, or to go all the way to Iceland to find the meaning of a simple English compound word?—*Carriage-Builders' Art Journal*.

## Editor's Work-bench.

### WOLVES AMONG THE CRAFT.

STARTLING as the announcement is, it is a melancholy truth that there is a worthless set of scamps peregrinating the country, and robbing by wholesale many of the hard-working members of our noble craft; and this, we are pained to confess, too, is done under color of law.

Every few days letters come to this office asking for information and advice in regard to some pretended patent on some article notoriously known as having been in common use for many years. Some mean fellow, too thick-skulled to turn out a decent job at carriage work, or too deficient in business qualifications to carry on an honest trade, starts out with the determination to speculate upon men's fears—knowing, better than they understand anything else, that men generally stand in great terror of a threatened law suit. This *weakness* in some individuals has been the direct cause of much trouble to the fraternity, and the prolific source of ill-gotten gain for dishonesty. Where these troubles will end, unless the craft present a bolder front, no human mind can determine, for every dollar paid these itinerant wolves is so much capital supplied them for swindling somebody else, and, in a certain sense, goes to constitute the robbed *a particeps criminis* with the robber. Should every member of the trade "shut down" on these fellows, they would very soon have to choose between two extremes—go honestly to work, or bring up in the poor-house; and we have very little doubt that even the inmates of such a place would feel themselves disgraced and lowered by the company of the new-comer.

But some tell us they did not know such and such an article was patented until some pettifogging lawyer wrote them a letter stating that his client, Swindle-them, had instructed him to commence a suit against them for infringement upon a pretended patent, unless they step forward and settle at once. Our files contain many such letters of late, with the additional information that they have always supposed themselves engaged in an honorable business, infringing upon the rights of no man, and in some cases that they have already paid for the patent on which damages are claimed. Poor fellows! we scarcely know whether to laugh at or pity them. The very thing inquired about, perhaps, has already been fully *ventilated* in our pages, and that should have fully posted them, had they not, when our agent called upon them to subscribe for our journal, given him the cold shoulder, and sent him away with the discouraging remark that they "could see no use for such a publication." To laugh at them in their "troubles," under such circumstances, would seem natural, and yet, we confess, "a fellow-feeling" inclines us to pity them. Probably the thought has never crossed their minds, that it is handy to have a complete set of our Magazine bound up, and kept in the office as a work of reference, in anticipation of such visitors. Here would have been found a complete journal of all the patents relating to carriages during the last six years, fully recorded. When Swindle-them first called, they might have learned their rights from our pages, and prepared themselves for a show of legal fight, which would have settled the matter at once, by driving off an impostor. We charge all

such with having committed, unwittingly, two comprehensive sins—those of omission and commission—one in not taking our Magazine, unflinchingly and faithfully devoted to their best interests; and the other—possibly the lesser sin—disturbing our editorial equilibrium by so often running to us with a tale of wrongs done them.

#### THE FUTURE OF CARRIAGE-MAKING.

NOTWITHSTANDING that our political horizon is somewhat obscured by war-clouds, yet, contrary to the predictions of many, the business interests of the country—that of the carriage-makers among the rest—never appeared in a brighter light than now. It was thought that the high prices charged for nearly all the material, coupled with the excise tax imposed on the manufacture a year ago, and steadily increasing since, would have the effect to break down the business; but, instead of this, with the issue of greenbacks the call for carriages seems to have increased to an unusual extent—so great, indeed, is the demand, that, with the limited number of skilled workmen now obtainable, a supply can scarcely be obtained. The present prospects are, that this unusual demand, instead of lessening, must go on increasing. All history has shown that an inflated currency tends to stimulate every branch of industry. How long prosperity may continue to attend such industry, is questionable; but the enterprise and indomitable spirit usually manifested by Americans, leads us to conclude that in this instance it must long continue. Everything indicates that we have entered upon one of the most successful careers which has ever favored any people since the world began. It is true that jealous nations are frowning upon us with envy; but, regardless of these things, with our noble rivers, and net-work of canals and railroads intersecting the most important points throughout the land, we are prospectively sure to become, in time, the richest and most independent nation that ever set up for itself, or filled a page in history.

Who will dispute the fact, with present evidences before his eyes, that as wealth accumulates, in the same ratio will luxuries be in demand? We have many, within our circle of acquaintance, who, a few years since, were "poor as a church mouse," but, since the rebellion broke out, have become millionaires, and are now rolling along in their splendid equipages, cutting as great a swell as some European lord. Indeed, while the aristocracy of the old world is dying out, it would seem to be taking root and spreading its branches in the new. Plain John Smith, who was formerly content to drive out on the avenue, in his buggy, alone, of an afternoon, now thinks that he is lacking in dignity unless he has a "contraband" seated beside him, *dressed to kill*, in the fantastical fixings of European folly. Mrs. Smith, who once *could* sometimes ride in a buggy, to be equal with her "lord" in show-off, now visits Stewart's in her coupé, with the contraband in liv-



ery mounted on the box, when she makes purchases of dry goods for the juvenile Smiths. Then again the family must have a costly phaeton, for afternoon excursions in the Central Park and to the High Bridge, and a fine coach for going to church in—things once never dreamed of—all which involves expense. Here are four vehicles in use where one—and that not very costly—was formerly kept, in defiance of the expenses incurred with the coach-maker, to keep them in repair, and the recently imposed excise taxes. Such an establishment, a few years ago, would, as tending to ruin, have brought down upon the guilty the condemnation of half the newspaper editors in the land.

To still further ape the fashions of the old world, the style of our carriages, heretofore peculiar to ourselves, is fast being molded more in conformity with, and after the clumsy designs of, foreign importation. This has been effected, to some extent, by a manufacturer in another city, who, after adopting these designs, has placed the manufactured article before the New York public as the offspring of his own ingenuity. Of this class is the individual, who, as a palliative for wounded ambition, writes to our now defunct cotemporary, "we are sorry we cannot, in this country, show as good a journal as yours," when, in fact, it was evident that all the practical value *that* ever possessed was borrowed from this.

There is one thing suggestive to the reader's mind; and that is the fact that, with the present scarcity of operatives, there is no probable danger of overstocking the market with ready-made carriages. The demand is likely to continue in excess of supply for some time to come. The only fear reasonably entertained by manufacturers is, that the prices realized for the work cannot be made to keep step with the rise of material. At present, the advantages of trade in this respect are clearly more with the dealers than with the manufacturers. The dealers have this advantage—they know exactly what the vehicle they sell costs them; the manufacturer, on the contrary, too often never knows, and cannot really tell, whether he is making or losing money. Carriage-makers, generally, are too unskillful in figures and too anxious to sell to ever become rich.

#### EDITORIAL CHIPS AND SHAVINGS.

A NEW IDEA.—They have got up a new style of carriage in Paris, adapted to the wants of lazy travelers. It is constructed to contain four seats, and is so arranged that when it moves along the body revolves, and the passengers have their eyes turned in every direction, without taking the trouble of twisting their necks to see the country around them. What next?

NEW RENDERING OF AN OLD QUOTATION.—The London *Punch* says: "Many of our public conveyances are full of draughts, owing to broken panes of glass and badly fitting windows. Sir Richard Mayne it was, we believe,

who said that this fact could not be denied, but that it was no good making a row about it, because '*De gusty 'bus non disputandum.*'"

COTTAGES ON WHEELS.—Sydney Smith says that when he was thirty-five years of age, "there were no quick and excellent cabs running. If he wanted to go beyond a walk, he must fain get into one of those 'cottages on wheels,' a hackney-coach, of which there was [at the time he wrote] only one existing in London. But these hackney-coaches were themselves a modern improvement." If, in the days of the youth of the witty writer we have quoted, he traveled to certain parts of the kingdom, he went in a slow wagon, as he was poor; he must otherwise go in the basket of a stage-coach, where his clothes were rubbed all to pieces. In the very best of society, he says, "one-third of the gentlemen were always drunk."

IRON WAGON COMPANIES.—The idea of building carriages entirely of iron has been abandoned, we believe, by every sensible mechanic in this country; but, judging from the advertisements in the London *Engineer*, there are some individuals in England who still advocate their utility. The Metropolitan Railway Carriage and Wagon Company (Limited), Saltby Works, Birmingham, notify the public, among other things, that they build wagons of iron, of every description, "either for cash or deferred payments." Another "*limited*" company in Manchester advertise that they manufacture "wrought and cast-iron carriage and wagon wheels, tires, axles, &c. With what tenacity some people hold on to *fossils!*"

IRON CARRIAGE HUBS.—A late number of the London *Engineer* gives the drawings and specifications of a patent taken out by one George Gray, of Greenwich, for iron carriage-hubs. In a subsequent number, Wm. Renshaw, of Manchester, pronounces it invalid, and advises the inventor to look at Wilk's specifications, No. 3,713, date 1813; Parly's ditto, No. 9,990, date 1843; and also Baron Henry de Bode's, No. 2,163, date 1853, for the proofs of his decision. The above facts may be of interest to the American public, since the same thing was *invented* and patented here as late as January, 1855.

#### FOREIGN IMPROVEMENTS IN CARRIAGES.

BRAKE FOR VEHICLES.—October 13, 1862. J. Gumbley, of Llantrissant, Glamorgan, has constructed the apparatus for a brake in such a manner that the power or pressure exerted by a horse in keeping back a vehicle in descending a hill or incline, shall be so transferred or transmitted as to form a brake on to or against the wheel. This may be effected as follows:—The breeching or other means on which the horse acts or presses to keep back the vehicle, instead of being attached to the shaft strap or pole, is attached to a chain or strap, or to chains or straps; such chain or strap, or each such chain or strap, runs round a pulley fixed on the under part of the shaft, or at the end of the pole, or in such like position, and thence passes to the end of a lever which works on a pin or axis at the opposite side of the vehicle; this pin or axis is fixed through the shaft, or in other convenient part, and the lever carries the brake-block, skid, or similar contrivance. When the horse applies pressure against the breeching or other means on which it acts for keeping back the vehicle, the levers will be thereby worked, and will bring the brake-blocks or other equivalent contrivance into action.

**CARRIAGE-BODIES.**—November 6, 1862. S. Robotham, of Birmingham. This invention relates to carriage-bodies, and has for its object an improved manufacture of the backs and arms thereof, or the part forming the back and arms of the body. For the purposes of this invention the inventor constructs a frame-work or outline of the desired shape, and similar to the construction hitherto used for the support of japanned leather and other materials, and this frame-work or outline he fills in with ductile sheet metal. He takes plain, perforated, or embossed sheet metal—if plain, he cuts a blank and shapes it on a block, pressing it or beating it into form; he then finishes it by hammering it or otherwise. Heat may be applied to anneal or facilitate the manipulation. *Not proceeded with.*

**HANSOM CABS.**—November 15, 1862. J. Rimmer, of Liverpool. The main objects of this invention are to prevent, or reduce to a minimum, jolting and vibration of the body and shafts, and parts thereof attached, of Hansom cabs, and to bring the horse nearer to the body of such Hansom cabs than has been practicable hitherto, and thus make them easier of traction or movement. To the body of the cab, close to the heel-board, the inventor fastens a pillar or spindle, which he carries upward through the curved or otherwise formed hind-part of the shafts, or through or between a shoulder or shoulders, an eye or eyes, or their equivalents, attached thereto. On the said pillar or spindle he places one, two, or more helical or spiral springs, part of which is below and part above the shafts, or shoulders, or eyes thereon, and a sufficient number of nuts and washers or other arrangement for keeping the said springs in their places. The shafts are joined, by a pin or otherwise, to fixed or rigid stays, so that when the tire of a wheel passes over a stone, or anything above the level of the road, or into a rut, or any place under the level of the road, the joints allow the shafts to move and maintain the same relative position to the horse, and the helical or spiral springs above and below the ends of the shafts receiving the shock, and relieve the body of the vehicle from sudden jolt and subsequent vibration so disagreeable in all Hansom cabs now made. The rigid stays to which the shafts are jointed or coupled do not require (when helical or spiral springs, such as those already described, are used) to be carried so far forward as in those Hansom cabs where springs are now used, nor as in those with long, flat springs; consequently, the horse can be brought back close to the bow of the shafts and to the body. *Not proceeded with.*

**WHEELS.**—November 15, 1862. G. Gray, of Greenwich. The inventor uses a metal of peculiar construction by preference of cast-iron. Each nave is cast in two parts, in one of which the several mortices or sockets for the inner ends of the spokes are formed, and such sockets or mortices are made by preference with parallel sides, the mortices radiating from the center of the nave. It is preferred that the angular parts of the nave, which come between the spokes, should be cast hollow in order to obtain lightness. The second or outside part of the casting simply consists of an outside cover to the nave, which is fixed to it by means of screws, the ends of which screw into an interposed disc or flat ring of wrought iron, and this disc or ring is fixed to the first-mentioned part of the casting by means of screw-bolts and nuts, the heads of which bolts are countersunk in the disc or ring, and the

screw bolts pass through holes through the angular parts of the casting which comes between the spokes. In putting a wheel together, the wrought-iron disc or flat ring is put into its place, and so that it does not come in contact with the casting, but is held by movable pieces a short distance away from it; the screw-bolts are then passed through the ring and the casting, the nuts are then screwed up, and the ends of the wood spokes are driven into their places, the tenons being slightly taper. The flat ring or disc does not fit close around the cylindrical central part of the casting of the nave, against which the inner ends of the spokes come when they are driven home, and the fact of their being driven home will at once be seen through the openings in the center of the ring or disc. The spokes having been driven in their places, the outer plate is put into its place and fixed by screws to the wrought-iron disc. Should the inner ends of the spokes shrink, the disc may be tightened by nuts.

**TIME INDICATOR FOR PUBLIC VEHICLES.**—Nov. 21, 1862. A. Sutton, Paris. The chief object of this invention is to indicate to the passengers of public carriages that ply for hire the amount of fare for which they are liable, and to record, for the information of the proprietors of such carriages, the daily earnings of the driver. To this end the patentee mounts, on any convenient part of the carriage, say at the side of the driver's seat, a clock movement, provided with a double set of index hands and a divided dial corresponding thereto. A pair of central hands are used to show, on divisions concentric with the clock case, the time the vehicle is on hire by a passenger, and the fare required to be paid. The second set of hands, which may with advantage be placed eccentrically, is employed for noting the total of the day's earnings. At the sides of the clock case are printed in legible characters the words "hired" and "for hire," and the clock case is either mounted on a hinge that will allow of its being turned to the right or left at pleasure, so as to hide one or other of these notices, or the clock case may be fixed, and a movable hinged cover, or its equivalent, may be used for obscuring either notice at pleasure. A further object of this hinged arrangement will be presently explained. To enable to produce the above-mentioned indications, it is necessary that it should act only when the vehicle is on hire, its action being suspended at the completion of such hiring. It is therefore necessary that either the clock or the cover should be turned on its hinge at the settlement of each fare, and that the notice "for hire" be thereby brought into sight, and the notice "hired" be temporarily hidden. In doing this the action of the clock-work of the indicator will be suspended, and the central index hands will be thrown back to zero or their starting point, by means of a rack and pinion, while the other index hands will be simply arrested in their progress. When, however, the requisite movement is made for exposing the notice "hired," the action of the clock-work of the indicator will recommence. This intermittent action is produced by the intervention of cams contained in or adapted to the hinge part of the apparatus, and set in action by simply turning the apparatus on the hinge. These cams, when caused to act by the turning of the hinged piece in the direction to expose the word "hired," withdraw a reciprocating rod or lever which is employed for stopping the action of the clock-work. Both sets of hands will then commence to move forward

according to time. Should, however, the passenger alight before a course is completed, it will be desirable to indicate, by a rapid progressive motion of all the hands, that the fare for a course is due. This is also effected by means of the arms before mentioned. To this end a sliding-piece or lever (operated by the cams when the hinge is again set in action) serves by its connection with a segment rack—which is in gear with a pinion on the central arbor—to turn the central index hands forward, in order to complete a course (at the same time actuating the recording index hands), and then to return the central index hands to zero. It will be obvious that, if it is preferred, the indicating dials may be arranged concentrically, and the index hands mounted centrally. This will, of course, involve a modification of the wheel-work, as is well known; but as the clock-work itself is of the ordinary construction for counting instruments, a description of it is unnecessary.

#### AMERICAN PATENTED INVENTIONS.

June 30. CONSTRUCTION OF WHEELED VEHICLES.—Oren E. Miles, of Aurora, Ill. (Patented Feb. 5, 1862): I claim, *First*, in wheel vehicles the arrangement of the rotating arm, C, and the wheel, hub, or center, B, the latter being fitted within the other, and confined and released by the bolt, *c*, or its equivalent, substantially in the manner and for the purpose herein set forth. *Second*, I claim in wheel vehicles the arrangement of the bolster, A, truss rods, *f*, center frame or post, C, center bearing frames, E, or its equivalent, and a rotating arm, C, carrying a wheel rigidly connected, substantially as and for the purpose herein set forth. *Third*, I claim in wheel vehicles having a rotating arm, C, rigidly connected with the wheel, B, the within described and represented arrangement of the springs, *s* and *h*, and guiding-pin, *i*, relatively to the bolster, A, hole, *j*, and box, D, or their equivalents, for the purpose set forth. *Fourth*, I claim in wheel vehicles the within described arrangement of the rotating arm, C, parts *k k*, and trunnions, *l l*, relatively to the levers, *r r*, frame, *m*, and block, G, or their respective equivalents, for the purpose above set forth.

ATTACHING HUBS TO WAGONS.—A. E. Smith, of Bronxville, N. Y.: I claim the use of the ledge, M, formed on the inside of the screw cap, L, in combination with the revolving linch-pin, K, and axle, A, for the purpose hereinbefore set forth.

CASTING BOXES FOR CARRIAGE AXLES.—Samuel Williamson, of Cincinnati, O.: I claim the cast-iron flask, H H, gate, A, in combination with the sand core, C, attached to the chill, E; operating in the manner and for the purpose substantially as set forth.

July 14. CARRIAGE SPRINGS.—C. B. Galentine, of Brooklyn Centre, O.: I claim the application of a self-adjusting, triangular brace to land carriages in such a manner as to retain the parts of the springs and their attachments in their proper relations, and thus to secure the parts from undue strain or breaking by the motion of the carriage.

HOLD-BACK FOR WAGONS.—James McNamee, of Easton, Pa.: I claim the combination of the rod C, spring, D, cross-bars, *e g*, U-shaped link, B, chain, A, and ring, *f*, when the said parts are constructed and arranged as herein specified, and the whole employed as described to arrest sudden lateral motions of the forward end of the tongue.

Aug. 4. ADJUSTABLE CARRIAGE POLE.—L. C. Miner, of Hartford, Conn. (ante-dated Dec. 19th, 1862): I claim the arrangement of the adjustable circular slides, E, E, braces, B, B, binding clip, G, and the vibrating socket-joint connections, I, K, in combination with the evener bolt, C, and attachments, in the manner and for the purpose substantially as herein set forth and described.

BRUSH.—Samuel Morris, of Charlestown, Mass.: I claim the improved brush, substantially as described, as made with a japan or water-proof and flexible composition applied to the back, so as not only to cover and finish the same, and dispense with a solid separate covering plate, but enter the bristle holes

and hide them and the confining wires from view, substantially as specified.

11. AMBULANCE.—Clarissa Britain, of Saint Joseph, Mich.: I claim, *First*, the removable slotted posts, B, in combination with the transverse bars or rails, G, G', springs, H, holding-down bars, J, J, and wagon body, A, all arranged and operating substantially as and for the purposes described. *Second*, suspending the stretchers, E, E, upon poles, *c c*, arranged and supported upon springs, substantially in the manner herein described.

DUMPING WAGON.—R. W. Green, of Bradford, Pa.: I claim the box or body of the dumper, constructed with circular sides, J, J, and hinged sections, M, M, in combination with the pivoted frames, K, K, all arranged and operating substantially as and for the purposes specified.

DRAUGHT EQUALIZING ATTACHMENT FOR WHIFFLE-TREE ATTACHMENT, &C.—James Wilkinson, of Prophetstown, Ill.: I claim the combination of the double-tree, B, two pairs of whiffle-trees, D, D', traces, F, F', G, G', and neck-yoke, E, all arranged to operate as and for the purpose herein set forth.

18. AMBULANCE.—Augustus Wm. Siss, of New York City (ante-dated July 7, 1863): I claim, *First*, the movable seats, E, E', constructed and secured substantially as set forth. *Second*, the hinged cots or stretchers, K, K, in the described combination with the movable seats, E, E'. *Third*, the folding head and foot rests, M, N, applied to the hinged cots, K, K, substantially as shown and described. *Fourth*, the described arrangement of the water tank, U, and drawer, V, beneath the body, A, of the ambulance.

AXLE SKEIN.—Henry Phillips, of Auburn, N. Y., assignor to Messrs. Downs & Co., of Seneca Falls, N. Y.: I claim as a new article of manufacture the hollow cast-iron skein or journal, A, provided with the chilled bearing surfaces, *f f*, extending part way around the same, substantially as herein set forth.

25. MACHINE FOR UPSETTING TIRES.—Ira D. Card, of Danville, Cal.: I claim, *First*, the adjustable fulcrum head, G, with the self-acting wedge, F, constructed and operating as described. *Second*, I claim constructing the jaws, H, H, of the walls of the groove, in the manner and for the purpose of operating substantially as described.

HUB MACHINE.—J. B. Ripsom, of East Kendall, N. Y.: I claim clamping and sustaining the wheel in place, by means of the adjustable bars, E, connected with the ring, D, or its equivalent, the adjustable connections, G, and the block, C, arranged, combined, and operating substantially as herein set forth. I also claim, in combination with the connections, G, arranged as described, and the block, C, the projections, *k k*, provided with notches, *p p*, and shoulders, *g g*, and the cross-heads, *o o*, of the screw-shanks, for the purpose of retaining such connections in place, at any inclination, substantially as herein specified. I also claim in combination with the combination of the ring, D, independent center, H, and adjusting screws, *r r r*, or equivalent, relatively to the shaft, B, and the wheel, for the purpose of perfectly centering the latter, substantially as herein described. In combination with the screw-shaft, B, provided with the cutters, K L, and the center, H. I also claim the removable nut, *r*, for the purpose of easily removing the cutters from the bore, substantially as herein set forth. I also claim the special arrangement and combination of the whole machine, as herein set forth.

CARRIAGE SEAT.—Andrew J. Ritter, of Rahway, N. J. (ante-dated June 12, 1863): I claim, *First*, dividing and jointing the seat-rail, A, and converting the front part of the seat-rail, A, into a movable brace, for the purpose of supporting and working the seat board, C, as heretofore set forth. *Second*, the combination of the movable front rail, A, with the fall or seat board, C, and the supporting legs, I I, attached to the under side of the fall or seat board C, as and for the purpose herein set forth.

CARRIAGE COUPLING.—George P. Kimball (assignor to himself and T. H. Knight), of San Francisco, Cal.: I claim the combination of the axle, D, with the flange, *b*, pin, A, cap, C, clevis, E, and kingbolt, F, when constructed and arranged substantially in the manner and for the purpose herein described.

## CURRENT PRICES FOR CARRIAGE MATERIALS.

NEW YORK, November 18th, 1863.

Apron hooks and rings, per gross, \$1.25.  
 Axle-clips, according to length, per dozen, 50c., 63c., and 75c.  
 Axles, plain taper, from  $\frac{3}{4}$  to 1 in., \$5;  $1\frac{1}{2}$  in., \$6;  $1\frac{3}{4}$  in., \$6.50.  
 Do. Swelled taper, 1 in. and under, \$5.50;  $1\frac{1}{2}$  in., \$6;  $1\frac{3}{4}$  in., \$6.75;  $1\frac{1}{2}$  in., \$8.75;  $1\frac{3}{4}$  in., \$10.25.  
 ☞ These are a superior axle, and more frequently called for than any others.  
 Do. case-hardened, half-patent, \$7; do. \$8; do. \$8.50.  
 Bands, plated rim, under 3 in., \$1.75; over 3 in., \$2.  
 Do. Mail patent, \$2.50 a \$3.25.  
 Do. galvanized,  $3\frac{1}{2}$  in. and under, \$1; larger, \$1 a \$2.  
 Basket wood imitations, per foot, 88c.  
 ☞ When sent by express, \$2 for a lining board to a panel of 12 ft.  
 Bent poles, each \$1.12 $\frac{1}{2}$ .  
 Do. rims, under  $1\frac{1}{2}$  in., \$2 per set; extra hickory, \$2.50.  
 Do. seat rails, 44c. each, or \$4.50 per doz.  
 Do. shafts, per pair, 75c.; bundles, \$5.50; extra, \$6.  
 Bows, per set, light, 75c.; heavy, \$1.12.  
 Bolts, Philadelphia, per gross, as per printed list.  
 Do. T, per 100, \$3 a \$3.50.  
 Do. tire, \$1.05 a \$1.80, according to size.  
 Buckram, per yard, 20c. a 30c.  
 Buckles, per gross, 88c. a \$1.25.  
 Burlap, per yard, 25c.  
 Buttons, japanned, per paper, 15c.; per large gross, \$1.50.  
 Carriage-parts, buggy, carved, \$4.  
 Carpets, Brussels, per yard, \$2; velvet, \$2.75; oil-cloth, 60c. a 80c.  
 Castings, malleable iron, per lb, 15c.  
 Clip-kingbolts, each, 30c.  
 Cloths, body, \$3.75 a \$4.50; lining, \$2.25 a \$3.25. (See *Enameled*.)  
 ☞ A Union cloth, made expressly for carriages, and warranted not to fade, can be furnished for \$2 a \$2.25 per yard.  
 Cord, seaming, per lb, 25c.; netting, per yard, 5c.  
 Cotelines, per yard, \$5. a \$8.  
 Curtain frames, per dozen, \$1 a \$1.50.  
 Do. rollers, each, 75c. a \$1.  
 Dashes, buggy, \$1.75.  
 Door-handles, stiff, 50c. a 63c.; coach drop, per pair, \$2 a \$3.50.  
 Drugget, felt, \$1.62.  
 Enameled cloth, 5 qrs., 75c.; 50 in., \$1.50.  
 Enameled linen duck, 4 qrs., 55c.; 5 qrs., 75c.; 52 in., 90c. Colored, 15c. higher per yard.  
 Felloe plates, wrought, per lb, all sizes, 16c.  
 Fifth-wheels wrought, \$1.25 a \$1.75.  
 Fringes, festoon, per piece, \$1.75; narrow, per yard, 18c.  
 ☞ For a buggy top two pieces are required, and sometimes three.  
 Do. silk bullion, per yard, 35c. a 75c.  
 Do. worsted bullion, 4 in. deep, 35c.  
 Do. worsted carpet, per yard, 6c. a 10c.  
 Frogs, 38c. per pair, or \$1.63 per dozen.  
 Glue, per lb, 25c.  
 Hair, picked, per lb, 50c.  
 Hub-borers (Dole's) for light work, \$15; heavy, \$18 a \$20.  
 Hubs, light, morticed, \$1; unmorticed, 75c.—coach, morticed, \$1.50  
 Japan, per gallon, \$4.50.  
 Knobs, English, \$1.75 a \$2.  
 Laces, broad, silk, per yard, 70c. a 85c.; narrow,  $5\frac{1}{2}$ c.; silk, 8c. a 10c.  
 Do. broad, worsted, per yard, 31c. a 37 $\frac{1}{2}$ c.  
 Lamps, coach, \$14 a 18.  
 Lazy-backs, \$9 per doz.  
 Leather, collar, dash, 27c.; slit do., 17c.; enameled top, 27c.; harness, per lb, 45c.; flap, per foot, 15c. a 20c.  
 Linen, heavy, a new article for roofs of coaches, 55c. a 70c. per yard.  
 Moquet,  $1\frac{1}{2}$  yards wide, per yard, \$5.  
 Moss, per bale, 10c.  
 Mouldings, plated, per foot, 12c. a 15c.; lead, door, per piece, 30c.  
 Nails, lining, silver, per paper, 6c.; ivory, per gross, 25c.  
 Name-plates.  
 ☞ See advertisement under this head on 3d page of cover.  
 Oils, boiled, per gallon, \$1.50.  
 Paints. We quote white lead, extra, \$3; Eng. pat. black, 25c.  
 Pekin cloth, per yard, \$2.  
 ☞ A very good article for inside coach linings.  
 Plushes, per yard, \$2.  
 Pole-crabs, silver, \$5 a \$6; tips, \$1.12.  
 Rubbing stone, per lb, 12c.

Sand paper, per ream, \$3.75.

Screws, gimlet.

☞ Add to manufacturer's printed lists 20 per ct.

Do. ivory headed, per dozen, 38c. per gross, \$4.  
 Scrims (for canvassing), 15c.  
 Seats, buggy, pieced rails, \$1.75; solid rails, \$2.50.  
 Shaft-jacks (M. S. & S.'s), light, \$2.60; heavy, \$2.87. a \$3.25.  
 Do. tips, extra plated, per pair, 31c.  
 Silk, curtain, per yard, \$1 a \$2.25.  
 Slat-irons, wrought, per pair, 55c.  
 Slides, ivory, white and black, per doz., \$6; bone, per doz., \$1.50;  
 No. 18, \$1.75 per doz.  
 Speaking tubes, each, \$1.50.  
 Spindles, seat, per 100, \$1 a \$1.25.  
 Spring-bars, carved, per pair, \$1.  
 Springs, best temp. Swedes, per lb, 24c.; black, 17c.; bright, 18c.;  
 best tempered, 21c.  
 ☞ Two springs for a buggy weigh about 28 lbs. If both 4 plate, 34 to 40 lbs.  
 Spokes, buggy, per set, \$3.30, or about 5 $\frac{1}{2}$ c. each for all under  $1\frac{1}{2}$  in.  
 ☞ For extra hickory the charges are 7c. each.  
 Steel, Farist & Co.'s Homogeneous American, per lb, 16c.  
 Do. English Homogeneous, do. 20c.  
 Do. Compound tire, from \$6.50 to \$7.75, according to thickness.  
 Stump-joints, per dozen, \$1.25 a \$1.50.  
 Tacks, 5c. and upwards per paper.  
 Tassels, holder, per pair, 63c. a \$1; inside, per dozen, \$3; acorn  
 trigger, per dozen, \$1.25 a \$1.50.  
 Terry, per yard, \$7.  
 Top-props, Thos. pat., per set, 35c.; plain, com., 35c.  
 ☞ The patent props, with silver-plated nuts, per set, 87 $\frac{1}{2}$ c.  
 Tufts, ball, per gross, 50c.; common worsted, 12c. a 25c.  
 Thread, Marshall & Co.'s Machine, No. 432, \$2.40 per half lb; No.  
 532, \$2.75 do.; No. 632, \$3.50 do.  
 Turpentine, per gallon, \$3.75.  
 Twine, tufting, per ball, 35c.  
 Varnishes (Amer.), crown coach-body, \$5 a \$5.50; hard drying,  
 \$6.50; nonpareil, \$7.  
 Do. English, \$6.25 in gold, or equivalent in currency on the  
 day of purchase.  
 Do. American imitation of English, \$7.  
 Webbing, per piece, 44c.  
 Whiffle-trees, coach, turned, each, 25c.; per dozen, \$2.50.  
 Whiffle-tree spring books, \$3 per doz.  
 Whip-sockets, rubber, per dozen, \$7 a \$9; pat. leather, stitched, \$3.  
 Window lifter plates, per dozen, \$1.50.  
 Yokes, pole, each, 75c. to \$1.25.  
 Yoke-tips, 50c. a 75c.

We intend to carefully correct this list monthly, so as to enable those who commission us to make their purchases to ascertain by computation about the amount they require to remit us. This should be done, if a large sum, by draft to our order in New York, or if small, in a registered letter to our address. None but cash orders filled, and where C. O. D. bills are forwarded with the goods by express, charges for collection must be added, which amount in ordinary cases to from 25c. to \$1, according to distances. All this may be saved by sending us the money with the order. Please read notice of "General Business Agency," on 3d page of the cover, in connection with the above.

## TO READERS AND CORRESPONDENTS.

BACK VOLUMES of this work will be sold, in numbers, for \$3; when bound, for \$3.50, to which, if sent by mail, 48 cents must be added to prepay postage; if two or more volumes are called for at one time, they can be had for \$3 each, or will be sent by express, at the purchasers' expense, at the same price. The subscription to the Fifth Volume, now in course of publication, will be (in consequence of the advance in paper and printing) four dollars, IN ADVANCE, for the twelve numbers; and these will be issued, in 1863 for Jan., March, May, July, Sept., Nov., Dec., and afterwards monthly until the close of the volume in May, 1864.

AGENCY.—Our friend Mr. Henry Harper, who is traveling in the West, is authorized to take subscriptions for us, and receipt for moneys paid; and any contract he enters into concerning this Magazine will be honorably carried out by the Publisher. In Canada West, Mr. Robert McKinley, at St. Catharines (dealer in carriage-hardware), will act as our local agent.



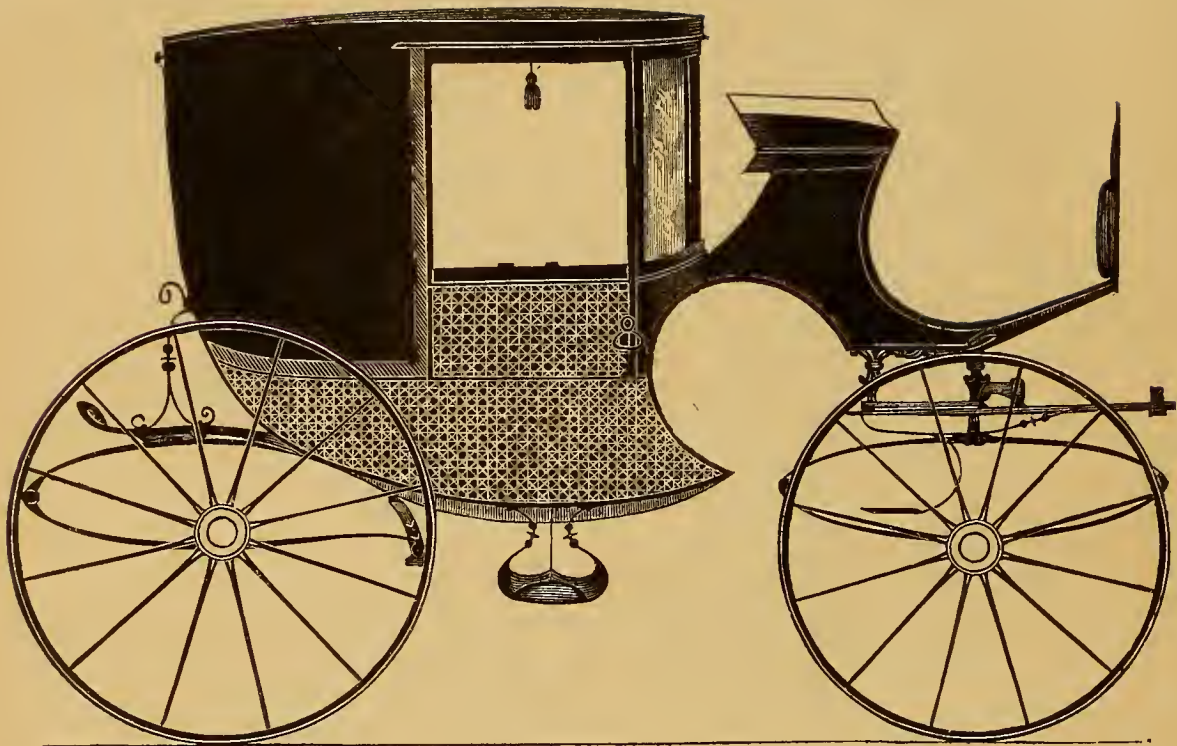

COMPASS-FRONT COUPÉ.— $\frac{1}{2}$  IN. SCALE.

*Designed expressly for the New York Coach-maker's Magazine.*

*Explained on page 120.*



EXTENSION TOP BAROUCH.— $\frac{1}{2}$  IN. SCALE.

*Engraved expressly for the New York Coach-maker's Magazine.*

*Explained on page 120.*







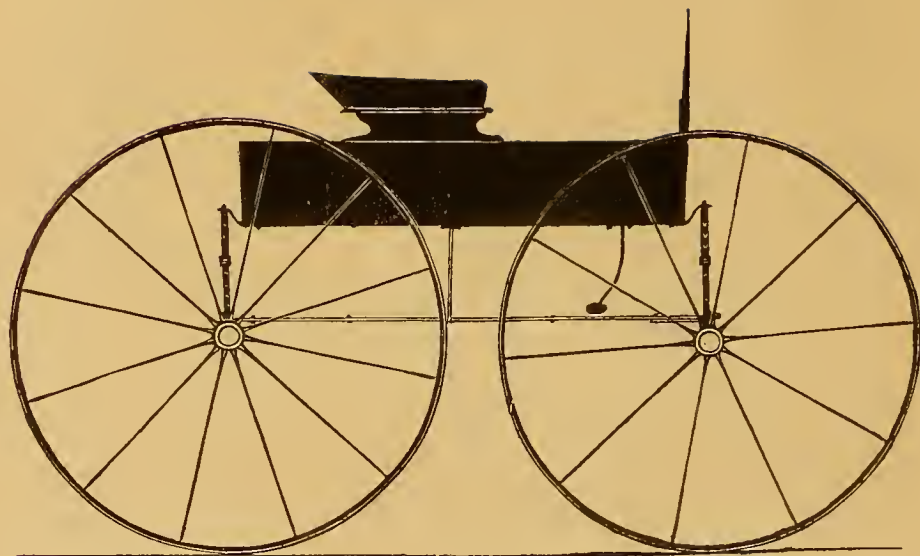

NEW YORK BOX-BUGGY.— $\frac{1}{2}$  IN. SCALE.

*Engraved expressly for the New York Coach-maker's Magazine.*

*Explained on page 120.*

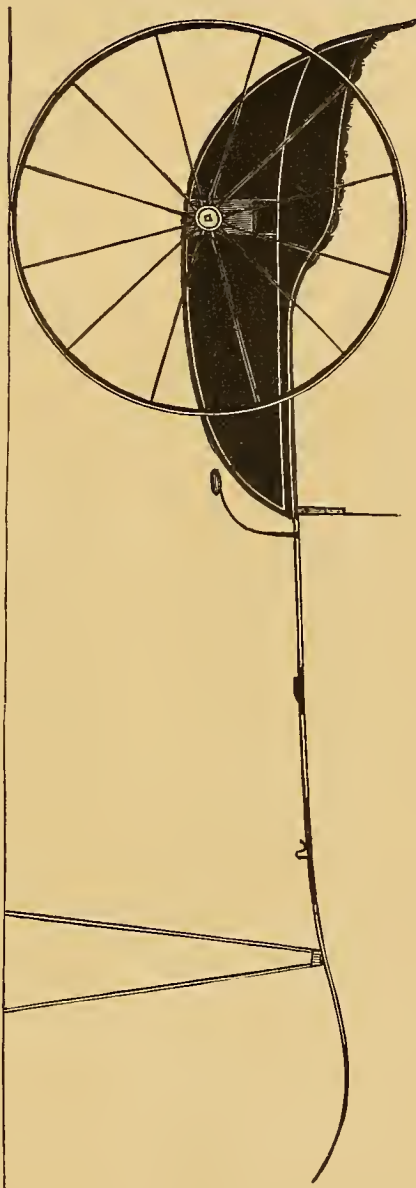

NEWPORT CART.— $\frac{1}{2}$  IN. SCALE.

*Engraved expressly for the New York Coach-maker's Magazine.*

*Explained on page 120.*





DEVOTED TO THE LITERARY, SOCIAL, AND MECHANICAL INTERESTS OF THE CRAFT.

Vol. V.

NEW YORK, JANUARY, 1864.

No. 8.

## Mechanical Literature.

### CARRIAGE WHEELS—THEIR MECHANICAL CONSTRUCTION, AND USE CONSIDERED.

BY HENRY HARPER.

It is unpleasant and a thankless task to speak of faults practiced by the members of any of the mechanical fraternities, yet, in the subject that we propose to consider, our labor would be lost if we did not notice in the most explicit terms faults to which many members of our craft are continually tending. These faults are more apparent in building wheels than in any other part of the trade. It cannot be denied that while we have made improvements in almost every other part of the wagon or carriage, for the last twenty years, yet in the one particular of wheels we have literally fallen into the "dark age," knowing, in many cases, very little about their mechanical use or construction.

To lessen the responsibility of this assertion, as regards myself, I will quote the language of an old veteran in the business, S. E. Todd, Esq., who is known to the readers of this Magazine as not only a scientific but ingenious mechanic. In an article published in 1855, on the subject of carriage-building, Mr. T. says: "I have worked at wagon-making from my boyhood, and met with a great many wagon-makers, and have never met with one who could tell why a wheel was made dishing at all, nor why one wheel was made more dishing than another, nor about how much dish will make the strongest wheel, nor what would be the precise effect if an axletree made correctly be turned with the hind side and forward side down respectively and alternately."

In my own experience I find many who, when you say anything about scientific rules for the craft to be governed by, will scout the idea at once. If they can make a wheel turn around as others do, that is enough. If a bad habit has crept into the trade by way of fashion, it will never be turned out by them. No; they are the very last to cling to it. Such men go through perhaps a long life, blessed with muscular strength and good intellectual powers (lacking culture), and at the close of life can only say that these blessings have been perverted to the injury of their fellow-beings. What else can their work be but

an injury? It is a positive fact, susceptible of the plainest mathematical proofs, that the value of a common lumber-wagon is lost, from one to ten times, by very many of the wagons that are now in use, owing entirely to the improper adjustment of the wheels. Again, it is a well known fact that a great many wagon and carriage wheels, made of the best quality of timber, with good joints, and got up with great care, do not give one-fourth the service that others do that have no more pains taken in selecting the timber or in construction. What is more, these inefficient wheels have gained the high position of *fashionable* wheels. Now how could this state of things exist if the majority of the craft understood their mechanical use and construction?

I have had occasion to say to one who had the charge of getting up work, that I would not build work in such or such a way, and I have always received the old stereotyped reply, "You can't sell it in this place if you don't." Such an excuse is an indication that he who makes it lacks knowledge of his business, and is forced to do wrong because others do so. We can, if we are properly educated, take a course as independent of this unmechanical influence in such matters as effectually as the mathematician in any of the positive sciences; and until we do so, we cannot claim any more respectability for our trade than the "hewers of wood and drawers of water."

Our system of mechanical education is much at fault, and, in fact, has got to be the nearest possible point to no education at all. The worst feature is yet to come, and that is, a great many who crowd themselves into the ranks of mechanics are so deplorably ignorant of their business that they really do not know that it is necessary to understand any more about it. I have seen "lots" of the latter class, and asked them to take a periodical that would give them some ideas about their business, but really they could not see the use of it.

To be able to understand the real use of a carriage wheel, we must fully understand the mechanical power that it exerts. By that means we shall know how to increase that power when required. For instance, if it is a wedge, we shall increase its power by making the angle of the wedge less. If it is a lever, we increase the power in proportion as we increase the arm of the lever, compared with the distance from the fulcrum to the weight which is to be lifted. A carriage wheel is simply a lever-power, and will be increased in proportion as we increase

the size of the wheel; yet, there is a counteracting effect, increasing the size the wheel has, that affects the motive-power, so that in certain cases we lose instead of gaining power by increasing the size beyond a certain point. These cases will be considered in their place. So the mechanic must not (as is sometimes the case) let himself run away with the one idea of enlarging the wheel to gain power. The resisting power which the carriage has on the horse is also a lever-power. Now in this case the study of the mechanic should be to increase the lever-power that the horse exerts on the carriage, and diminish the lever-power that the carriage has on the horse. *Practice, in fashionable carriages, is the reverse of this.*

The lever-power in a wheel is represented by Fig. 1. The line at A is the arm of the lever, B the fulcrum, C the distance from the fulcrum to the weight that is to be

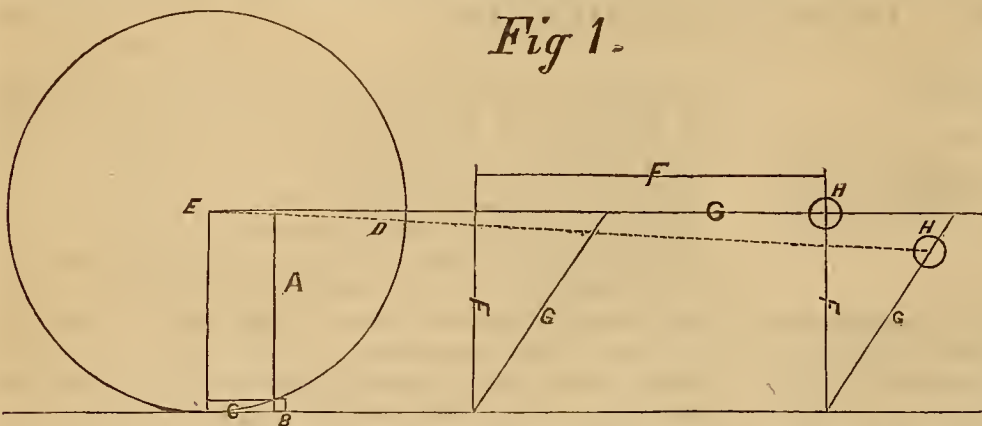

lifted over the fulcrum or obstacle, E the axle, D the line of draught. The motive-power which the horse contributes is communicated to the wheel from the under side of the axle by drawing it against the axle-box. In the diagram which we have presented we have made no allowance for any size to the axle, and the result is that the lever, or A, line is three times as long as the weight, or C, line. If one pound is applied to the D, or draught-line, it will raise three pounds at the end of the C, or weight line. But should we increase the axle to a size so that the radius would be equal to one of the three divisions of the lever-line, we would have a lever-line twice as long as the weight-line, and the power of the lever would be as two to one. One pound of draught would lift only two over the obstacle. Should we still increase the axle so that the radius would be equal to two of the divisions in the lever-line, there would be no gain of lever, and it would take one pound of draught to lift one pound over the obstacle. This illustration shows what we lose by increasing the size of the axle-arm.

If the wheel is enlarged to gain power in overcoming this same obstacle, the lever and weight-lines are both increased, but the lever-line is increased in a proportion of over three and one-third to one of the weight-line; therefore, the gain is over three of the lever to one resistance of the weight in lifting it over the obstacle. These calculations are all made with the supposition that the draught is horizontal with the under side of the axle-arm. Those who are familiar with the Fourth Volume of this Magazine have seen how the power could be increased or diminished by raising or lowering the draught line.

We will now show how the resistance of motion to a carriage acts as a lever on the horse. The amount of draught that a horse exerts depends much on his heft,

yet there are cases where a light horse can exert more power of draught than a heavier one. Such cases may be attributed to the superior knowledge that the lighter one has in taking advantage of the draught, and perhaps a superior muscular strength, by which he puts in operation the mechanical arrangement nature has furnished him with. In Fig. 1, F F F and G G G may represent the outlines of a horse seen in the different positions that he assumes when drawing. If the draught is very light, he travels in the upright position of F. If we increase the draught, he throws his body forward in the position of G. In the position of F, the mechanical power that he exerts is almost wholly obtained from the contraction and expansion of his muscles, with but little aid from the mechanical construction of lever-power which nature has beautifully arranged in his anatomy. The first position

is for locomotion alone; the second is for overcoming obstacles against locomotion. It will show us how hard it is to overcome obstacles against locomotion by the aid of the muscles alone, if we hold out our arm in a horizontal position from the body for any considerable length of time. This would be power created merely by contracting the muscles, and holding them rigidly in that position. It is extremely painful, we all know. The first lesson that a horse learns before he can be useful as a draught horse is to avoid any such strain on his muscles. We

do the same in holding a weight, by raising our arm above or dropping it below a horizontal line; in either case, the nearer we get it to a perpendicular line, the easier it is for us, because the tendency of the weight is in a perpendicular line, and the nearer we get the support and tendency in a line, the easier it is supported. Upon the same principle, the nearer we can get the draught-line and the power that the horse exerts into the same line, the less work the muscles have to do. The bones and joints are a complication of levers, and the office of muscle is to work those levers. The anatomist should understand this as well as the mechanic, and for my part, I should have greater confidence in a physician whose reasoning faculties had taught him how to hitch his horse to his buggy, than one who was ignorant of it. To follow this course of reasoning throughout, giving all the whys and wherefores, would be taking us further from our subject than would be profitable at present.

It will be seen by enlarging the wheel, that although, as we have said, we gain lever-power, yet, by raising the draught-line with the axle, we prevent the horse from putting the power that he exerts as near as he otherwise would into the line of the draught. In this diagram the F line is at a right angle with the D, or draught-line, but the position that the horse assumes by the G line approaches nearer to the draught-line. This relieves the horse some by his own judgment; but he cannot give himself any more relief by leaning forward, because it would throw him so much off from his balance that he would fall over forward, without being able to recover himself when the draught became lighter. In this case the practical and reasoning mechanic ought to bring his reasoning powers in favor of the horse, to carry out what the dumb animal's practical reasoning has taught him, when

so much can be gained by the assistance. But it is rather humiliating to us, as reasoning beings, professing to understand mechanical laws, that, instead of helping the horse to carry out his practical undersanding, we go to work and destroy the benefit he derives from his knowledge. We certainly do so, and, what is worse, it is done by that class of mechanics who place themselves at the head of the profession—those who make the fancy work. There cannot be a more shameful perversion of human understanding than is to be found in the practice of raising the whiffle-trees above the height of the under side of the axle. Draw a line from any point above the axle, E, to H, where the draught is attached to the hames, and you increase the angle between the draught-line and the line where the power is exerted. Draw a line below the axle, E, to H, and at the same time it lessens the effect that the wagon has on the horse.

Fig. 2 will illustrate our position. We have two wheels of exactly the same heft and size, with the block

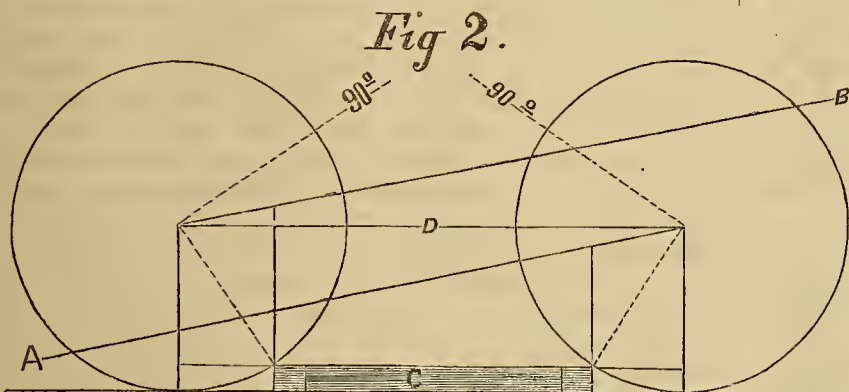

C separating them, on which we want to draw one of those wheels with the least amount of power that can be used, and we have two lines, A and B, to draw by. Can we have any doubt which line will draw the wheel up the easiest? Certainly not. The line B will draw the left-hand wheel up with less power than the line A will draw the right-hand wheel upon the block. If you take your dividers, and measure from the corner of the block C, where the dotted line from the axle touches it, you will find that where the draught-line, B, crosses the rim of the left-hand wheel the distance is more than it will measure from the same place on the right-hand wheel to where the line A crosses the rim. The motive-power of the line B is about one-third more on the left-hand wheel than the power of the line A is on the left-hand wheel.

These draught-lines will increase in power to lift the wheel over this obstacle, until they reach the dotted lines marked  $90^\circ$ . On the contrary, they will decrease in power as they recede from the dotted line of  $90^\circ$ , in exact ratio as they recede, until they reach the dotted line that touches the obstacle, and at that point they will have lost all power to raise the wheel over the obstacle; but if power enough is applied, it will crush the wheel without moving it. Therefore, if we suppose the right-hand wheel to be the horse, and the tugs lowered so that they drop into the A line, and the draught on the left-hand wheel remains in the direction of the line B, then the horse gains in power which he exerts on the wheel, and the wheel loses in power that it exerts on the horse. Should the draught-line and the lines in which the tugs are drawn be in the same direction, the same as the line D, then the horse would have no advantage over the wheel only by

the lever and weight-lines that are described in the wheel.

According to this theory, about one-fourth or one-third of the power that a horse expends on our most fashionable carriages is thrown away by a mistaken idea that fashionable workmen have in raising the draught of the tugs when they should be lowered. It will be asked if I can give any practical proofs of this theory. Yes, I can, most positively. Mr. S. D. White, of Berlin City, Wisconsin, had a wagon built five years ago for a draught-wagon in the city, securing all the advantages of draught as I have described. The wagon weighs 800 pounds, and is used with one horse. When the roads are in the best condition he draws 4,500 pounds in one load a distance of nearly one-half mile. That load would be a heavy one for any span of horses working in the ordinary wagons. There can be no question but that he draws at least one-third more on this than he can on ordinary wagons. The main feature and advantage in this wagon is the same as

I have described as being gained by lowering the draught; yet there is another advantage which is worthy of particular consideration. Although this wagon has been in use for five years, on a sharp, sandy-soil road, carrying loads that are almost incredible, yet the axles and axle-boxes show no signs of wear, and are just as good, to all appearance, as on the first day they were used. This shows that there has been but little friction on the axle, and this can be accounted for in no other way than by supposing that the axles are so set that the bearings are equally distributed on the under side. Stage coaches that run from this place on the same kind of sandy

road have their axles and axle-boxes worn so much that the axle sometimes has had to be upset after three months' wear. For the credit of the carriage factory where the repairing is done, they make the axles they reset wear much longer, and do what is called better service, which is only another name for making the coach run easy. Messrs. A. J. Work & Co., the proprietors of this carriage factory, have always shown a great skill in setting axles, being conscious of the importance of the same. They built Mr. White's wagon, which will challenge the whole world for easy draught, wearing qualifications, and practical utility. Mr. White invented the mechanical powers that are new in his wagon, and gave the orders for carrying out his plans. The benefit that Mr. White derives from his wagon, when summed up, fully equals the benefit that our calculations for making the draught easier would give.

We would not make these personal allusions to individuals, did not our subject demand it. Ignorance among the craft, on a subject so momentous, amounts almost to a crime against community, and we feel at liberty in taking almost any means to dispel it.

(To be continued.)

HORSE RAIL-CARS vs. OMNIBUSES.—These old time-honored "city institutions" are fast being driven off the track by the horse rail-cars, now running in almost every direction in New York. The tramways now being laid will soon complete the gridiron George Law has planned, in defiance of law, for his special benefit, and belt the city. Such is the progress of improvement, that in a short time the facilities for travel in this will not be exceeded by any other city.

THE TIREVILLE MISCELLANY;

BEING SELECTIONS FROM THE PRIVATE JOURNAL OF JOHN STILWAGEN, ESQ.

BY THE EDITOR.

(Continued from page 82.)

COMPLICATIONS in business frequently arise out of simple circumstances. The following facts may be given in illustration of an instance where a customer tried very hard to maintain aristocratical pretensions on a small outlay. A man, claiming to be a gentleman, presented himself at my office one morning, wishing me to tell him *about* what it would cost to repair an old carriage, at the same time mentioning in detail the items, which, at his request, I put on paper. This paper he carried away with him. Not yet having seen the carriage, of course I did not consider myself bound to anything by a paper drawn up under such circumstances. The next day my customer sent his carriage to my factory, and afterwards came himself, with a friend, to give special directions as to how he wished the work done. When called upon for the paper he had taken away, he stated that he had left it at his home, but that he could give it from memory, which he proceeded to do, a clerk at the same time committing it to paper. It was as follows:

“Doctor Wreath’s Rockaway—To be repainted; new hub-bands, and painted (not plated); axle-nuts capped; new tires and new bolts; reset axles; four short felloes; new apron; fall to front seat; new side curtains (back and front ones extra); re-covering glass frames; four sun-curtains (the balance extra); four glass-frame lifters (the fifth extra); replating door handles, or else new ones (if new, extra charge); *footmen holders and lollers* (inside holders) *to be left off*; new carpeting, \$10 extra. The whole was estimated at about \$155 00, not to include the carpet.”

Such was the estimate as agreed upon by the parties originally. As the work progressed, additional work was ordered, so that when the bill was presented it stood as below, and was thus rendered:

Doctor A. H. Wreath— To John Stilwagen, Dr.

To 2 new spokes in Rockaway wheels.....	\$0 75
5 short felloes.....	1 87
New set of tires and bolts.....	18 00
Resetting 2 axles.....	2 00
Hub-bands.....	1 50
Recapping axle nuts.....	1 00
Apron.....	4 00
Fall to front seat.....	2 00
7 new leather curtains.....	50 00
Recovering glase-frames.....	6 00
New head lining.....	12 00
Sun curtains.....	18 00
4 glass-frame lifters.....	7 00
New door handles.....	5 00
Recarpeting.....	10 00
Repainting.....	50 00
Ornamenting.....	1 00

\$190 12

TIREVILLE, Sept. 10th, 18—.

It will be seen that I put in one more fellow, three extra side curtains, two spokes, new head-lining, new door handles, and the carpetings extra. Some of these I have italicised in the bill. When the carriage was taken away, the doctor paid \$140 on account, promising to pay the balance soon. After calling on him, and being frequently put off with frivolous excuses, he finally refused to pay anything more. I therefore brought suit in the District Court, complaining—“That on the tenth day of September, 18—, the defendant was indebted to the plaintiff in the sum of one hundred and ninety dollars and twelve cents on account of services rendered by the plaintiff and his servants to the defendant, at his request, in Tireville, in repairing, refitting, and repainting a certain six-seated carriage belonging to the said defendant, and for materials and other necessary things furnished by the plaintiff in and about said work at the like request, which sum became due to him therefor from the defendant on the tenth day of September, 18—.

“That the plaintiff, on the tenth day of September, 18—, duly demanded payment of the same from the defendant; but no part thereof has been paid, except the sum of one hundred and forty dollars, which was paid on the 10th day of September, 18—; and the defendant is now justly indebted therefor to the plaintiff in the sum of fifty dollars and twelve cents, with interest from the tenth day of September, 18—. Wherefore the said plaintiff demands judgment,” &c.

To this complaint the defendant put in an answer, that he “denies, in the first place, that on the tenth day of September, 18—, or at any other time, he was indebted to said plaintiff in the sum of one hundred and ninety dollars and twelve cents, or in any other sum whatever, on the account for the services of said plaintiff or his servants in said complaint alleged, or on any account whatever. And this defendant denies that at his request, or otherwise, said plaintiff rendered to him the services in said complaint alleged, or any services whatever, or at his request furnished the materials or necessary things in said complaint mentioned, or any of them.

“2d. And this defendant further answering, alleges that on or about the tenth day of September, 18—, M. M. Wreath, who is the wife of this defendant, by this defendant as her agent, made and entered into a certain agreement or contract with said plaintiff, wherein and whereby said plaintiff covenanted and agreed, on his part, to render and perform all the necessary services, and furnish all necessary materials for the proper refitting and repairing of a certain carriage belonging to said M. M. Wreath, which said materials and services are the services and materials mentioned in plaintiff’s complaint, for the price or sum of one hundred dollars.

“That said M. M. Wreath, on her part, agreed to pay said plaintiff therefor the said sum of one hundred and forty dollars, which said sum she duly paid said plaintiff on the tenth day of September, 18—.

“3d. And this defendant, for a further and separate answer to plaintiff’s complaint herein, denies each and every allegation in said complaint contained, and every part and particular thereof not hereinbefore admitted. Wherefore defendant demands that plaintiff’s complaint herein be dismissed with costs.”

After three adjournments by plaintiff, the case was tried, defendant admitting that the work was done for him, since “In an action for services, the defendant can-



not set up that he acted only as agent, &c., unless he discloses the fact of the agency at the time of making the contract. By contracting in his own name, he made himself personally liable." (See *N. Y. Com. Pl., Cabre vs. Sturges.*) Again, "Married women and other persons not *sui generis* are disqualified from appointing an agent or attorney." (See *Snyder vs. Spenable, 1 Hill, 567.*) The defendant seemed to rest his hopes of success on the testimony given by himself and a second person that he had paid all he agreed to, and the fact, which he undertook to prove by his hostler, that after several weeks' use and exposure to a storm the cloth loosened on one of the glass-frames, and by affirming that I agreed to *make the carriage as good as new*—a thing every carriage-maker knows would be utterly impossible. The only other complaint in proof that the work was not done well was the fact that rust showed at the edges of the springs after a while. My readers will note that I had not done any work on the springs, and being an antiquated vehicle, at least in use twenty-five years, that rust oozed out is not to be wondered at. The utter unreasonableness of the defense must have been apparent to the judge, as I obtained a judgment for the amount of my bill, with costs and an allowance of seven dollars counsel fees. Rather lucky this time, especially for a carriage-maker, isn't it?

(To be continued.)

## EFFECTS OF WHEEL-CARRIAGES ON ROADS AND HORSES.

### CHAPTER II.

1. Conical Wheels injurious both to Roads and Horses. 2. Conical Wheels wear out faster than Cylindrical ones. 3. Cylindrical Wheels and Axles best—Subject to only three-fourths the usual Toll. 4. High Wheels not disadvantageous going up hill. 5. Broad-Wheel Wagons extremely injurious to the Roads. Projecting Heads of Tire-Nails. 6. Broad-Wheel Wagons not so advantageous to the Public Carrier as lighter Carriages.

1. I KNOW no prejudice more firmly rooted than that in favor of *dishing* or conical wheels. Much has been written, and well written, to show and to prove the absurdity of the use of them, but hitherto with very little effect. I think the principles and the effects of them may be stated in very few words.

Carriages are intended to travel *straight forward*; they ought, therefore, to be furnished with wheels the *natural tendency* of which should be to go straight forward. The same with a garden roller. Suppose any man to have a garden or field roller made six inches less in diameter at one end than at the other, what would not even the wheelwrights say of such a man? Yet such an act would be a counterpart of their own when they recommend broad conical wheels.\* The natural course of a rolling cylinder is a straight line, and the natural course of a rolling cone is a circle. Let us reverse their natural courses—that is, let us make a cylinder travel in a circle, and a cone in a straight line. It must be obvious that when each of these bodies is forced to travel, contrary to nature, in the course of the other, there must be a constant dragging or *twist* on the ground to keep it in its unnatural course. Such would be the case if a man were to drag a common garden roller round in a small circle; and such too would be the case if a man were to draw straight forward a garden roller made six inches less in diameter

at one end than at the other. The effect in both cases would be *precisely the same*. Each operation would be attended with prodigious labor, and the roller, in each case, by its twist on the ground, would break up and derange the gravel beneath. Now it is well known that the machine constantly in use in numberless manufactories, as the best that has hitherto been invented for expeditiously and effectually grinding to powder the hardest and toughest materials, is a cylinder forced round in a circle. Therefore, as a cylinder moving in a circle is the best machine that the ingenuity of man has hitherto produced for pulverizing the hardest and toughest materials, and as this is effected by the twist or drag produced between the edge of the cylinder and the surface on which it rolls, and as the twist or drag is precisely the same in the case of a cone forced straight forward, I think I may be borne out in my opinion that a heavy wagon, with broad conical wheels, is the most complete, the most efficacious machine that the art of man, in the present state of science, could construct for grinding to powder the materials of our roads.\*

2. And it is also true that as the wheel grinds the road, in *that proportion* does the road grind the wheel. The tire of cylindrical wheels, therefore, would last probably many times as long as that of conical wheels.

3. It appearing then that the cylindrical wheel only has a natural tendency to roll straight forward, all carriage wheels ought to be so constructed. Consequently, the ends of the axles ought not to be conical or tapered, nor bent down, as they are now made, but the axle ought to be put in a lathe, and both ends turned, like the two ends of a spindle for mill-work, cylindrical—that is to say, of the same size or diameter at the ends as they are at the shoulders, and, of course, the boxes should be cylindrical also. It should be known that wheels of this construction are liable to only three-fourths of the usual toll, by the 55th Geo. III., chap. 119, at the discretion of the trustees.

4. It is a general notion that high wheels act disadvantageously going up hill. That this is not the fact is demonstrated by the ingenious author before cited. He says: "Wheels when ascending inclined planes, and when the line of traction is kept parallel to their ascent, notwithstanding they act as levers, yet in this case the action of the weight will increase with that of the power gained by the increased size of the wheel, which size, therefore, will be of no other consequence than by lessening the friction, as it does in planes."† It seems the author is showing that high wheels possess no philosophical *advantage* over lower ones, in ascending hills, other than they have on level ground; but he also shows that neither have they any disadvantage.

5. It being shown above that the conical wheels of broad-wheel wagons are the same in operation and effect on the materials of the roads as drug-mills, it follows, of course, that all that portion of labor which is applied to the conical wheel to keep it in a straight course, more than would be required to impel it in its natural circle, is so much power not merely wasted, but most mischievously and most effectively applied in *grinding* the materials of

\* This subject has been *ventilated* by our able correspondent H. H., on page 3 of our Fourth Volume, in reviewing an article from *The Carriage-Builders' Art Journal*, republished on page 145 of our Third Volume.—Ed.

\* On looking over the essay on wheel-carriages, published in the year 1813, by Richard Lovell Edgeworth, I find the same comparison in illustration of its effects on broad conical wheels. But as the above is copied from my own manuscript, written twenty years ago, I hope not to incur the charge of plagiarism.—AUTHOR'S NOTE.

† Article on wheel-carriages, p. 32.

the road into powder; and as these wagons weigh in summer eight tons each, the silent mischief effected by these four drug-mills, of two tons weight each, is great beyond calculation. How much power is thus misapplied may be conceived, as it frequently requires ten of the heaviest horses to draw it, which is just sixteen hundred weight each—a weight sometimes drawn by light horses in stage coaches, and at least at three times the pace!

Lest a total silence on the subject of projecting heads to the [tire] nails of wheels might be construed into an approval of their use, I am induced to make a remark or two upon them. First, the effect of round projecting heads, when the carriage is heavily loaded, the weight of the wheel with its load pressing *only on a point*, is that inevitable destruction must ensue to the stone with which it happens to come in contact, even though such stone were firmly imbedded in the road. And, secondly, as they affect the horses, it is demonstrable that they are extremely injurious, because, in this point of view, it matters not whether these round knobs of iron be affixed to the wheels, or whether the wheels be smooth and these knobs of iron laid in the path of the wheels. Now surely even the most inexperienced carter, were he driving a wagon with smooth wheels, and seeing such knobs of iron strewed along the road in two tracks, would endeavor to avoid them, well knowing that his horses would draw their load more easily on any other part of the road. But these large heads are of no use whatever to the wheels, because, if the nails are properly countersunk, and the heads made *exactly* alike, for which purpose they should be made in a *mould*, and so adjusted to the hole in the tire as to hold fast at the *bottom* of the hole, the tire-rim will remain firm until it is reduced to the thickness of a penny-piece; whereas, if the nails hold only at the *top*, as this wears away, the tire of course soon becomes loose. Therefore, as projecting heads to tire nails are extremely injurious to the roads, and in a very great degree productive of increased labor to the horses, and as they are in every other point of view entirely useless, they ought, I think, to be absolutely prohibited by act of Parliament.

6. It is a happy coincidence, that frequently what tends to private advantage tends also to the advantage of the public. I am glad to see these Gothic vehicles, which are objects of terror to the traveler, and which are destructive in the highest degree to the roads, gradually giving way to light carriages, drawn by four horses, and driven, as coaches are, by a man on the box. The owners have discovered the secret that horses in these carriages can draw nearly as much weight five or six miles per hour as other horses, nearly twice as heavy, can draw in heavy wagons, about two miles per hour.

Admitting the truth of the preceding statement respecting heavy wagons, it follows that instead of being *encouraged*, as they now are, by *low tolls*, and in some cases by an *entire exemption* from toll, they ought to be subjected to a toll that would soon effect their extinction.

### CHAPTER III.

1. Modern Stage-Coaches Unphilosophical. Supposed Origin of the Custom of Persons riding on the Tops of them. 2. Regulations for the Security of Passengers suggested. 3. All Passengers by Public Carriages might be, and ought to be protected from the Weather. 4. Objections Answered. Traces of Horses drawing ought to be placed horizontally. By the present Construction of Coaches, Horses have to draw the same Load over the same Obstruction twice. 5. Center of Gravity of these Coaches simply illustrated.

1. In the construction and use of stage coaches, not-

withstanding the display of paint and varnish, I think there is less display of anything like science or even common sense, than in most things about us. I have often questioned whence the absurd custom of persons riding on the tops of coaches, over the heads of one another, and the solution is this: when coaches were first built, the top was considerably convex—a form which naturally presented itself to the builder to turn off the rain.

This was undoubtedly the use, and the sole use, of that part of the carriage, most likely, for a century after it was first invented; but it was, in my opinion, no more contemplated by the early builders of coaches that men should ride on the tops of them than it now is that they should ride on the tops of sedan-chairs. The one is just as reasonable—just as unreasonable and absurd—as the other. I have no doubt but that the custom originated thus: A coachman, driving along, overtakes a poor fellow on the road. "Coachman! can you give me a lift?" "No; I'm quite full; I've no room on the box." "Oh! let me get up; I can ride on the top of the coach." The poor traveler mounts aloft, and holds on as far as he is going, and the coachman gets his *shilling*. This is the *secret*. Next time the coachman takes up *two*, and after a little time the thing attracts the notice of the master, who perchance may like shillings as well as his man. Then follow arrangements for outside passengers; first the foot-board behind the boot, to support the feet, and to prevent people from falling through between the boot and the body of the coach; then the bridle, a strap of leather, one end fastened to one side and the other end fastened to the other side of the coachman's box, long enough for the outside passengers to hold themselves on by it. All this I well remember. Then followed the side-irons; then similar arrangements at the back part of the coach; and lastly, the dicky-seat; and all this for the sake of the *shillings*—all an innovation, thus accidentally introduced, contrary to the use for which coaches were first made—sanctioned and regulated too by the sage authority of the British Legislature, who have decreed that only twelve persons besides the coachman, and perhaps half a ton of luggage, shall be thus mounted aloft—all in defiance of every principle of sound philosophy and common sense, and at the peril of the life of every traveler, inside or outside, who goes by these coaches—a gross reflection on the wisdom of the Legislature and on the good sense of the nation!

2. I would propose a concise act of Parliament for the regulation of these coaches, to consist of only two clauses: First, that no passenger shall be allowed to sit on any seat, cushion, luggage, or other thing, higher than five feet from the ground, excepting one—only one—person on the box with the coachman. Secondly, that neither the roof of the coach, nor any luggage, nor any other thing belonging to or about the coach, excepting only the coachman and one person sitting by him, shall, on any account whatever, exceed eight feet four inches from the ground.

3. These two enactments would be sufficient for the public security, and ample scope would be left for the exercise of skill. If it be necessary to carry a large number of persons in one vehicle, they may be accommodated by a series of cross-seats, one behind another, which may be divided into compartments for passengers of different degrees, and another compartment for luggage. And every person who travels ought to be protected from

the weather. There can be no question but that many a poor traveler, who has not a second coat to his back, receives what may be his death-warrant, when exposed for a winter's night to frost and snow on one of these coaches. The poor ought to be sheltered, as well as the rich. The whole of our coach system is unphilosophical and barbarous—unworthy of such an enlightened country as England.\*

4. Here it may be objected that the consequence of lengthening the carriage and lowering the load will be, that the weight would follow more heavily after the horses. It would certainly be difficult to satisfy such objectors, who would be likely to be *men of experience*, that is to say, men brought up in a routine of practice, yet totally ignorant of principles. It seems as though they had a notion that the fore wheel of a carriage, when closely followed by the hind wheel, makes haste out of its way; as a little boy at school, when pursued by a bigger boy, runs as fast as he can, for fear of being tripped up. All these notions about the necessity of horses being *close to their work*, and wheels following as nearly as possible after each other,† and of coaches that are loaded high moving lighter than when the load is low, are completely refuted by the actual experiments of Richard Lovell Edgeworth. See his work.

It is very true that if the wheel-horses draw *upward*, by having the traces fixed to the carriage at points lower than the points at which they are attached to the harness, they have a firmer hold on the ground than they otherwise would have; but in such a case the horses *lift* a part of the load, and what they lift they *carry*; and what they thus carry, they *carry on their necks or shoulders*. I have known an instance of a man who could not get his horse and cart up the ascent of a bridge, who, after much persuasion from a by-stander, was induced to get upon the horse's back, when the horse drew the load without difficulty: I have also observed, when going up a hill in a post-chaise, that the horse with a post-boy on its back drew more steadily, more firmly, and with *greater ease* than the other.‡ But no man, surely, would think of putting a weight upon a horse's *neck*, in order that he might have a firmer hold on the ground. Yet, inasmuch as any effect of this kind is produced by horses drawing *upward*, it is by *lifting* a part of the load with their *neck* or *shoulders*, and consequently with their *fore feet* only. But as such an act would scarcely find an advocate, it follows that the traces of all horses drawing ought to be placed in a horizontal position.

But if traces are fixed horizontally, it matters not, as regards the draught of the horses, whether they are two yards or six yards long; neither, if carriages traveled only on roads that were perfectly flat and even, would it be important whether the axles of a coach were six feet apart or ten feet apart, as it might affect either the passengers or the horses. But it is clearly demonstrable that the present construction of stage coaches is extremely *unfavorable* to the draught of horses; that is to say, a coach

\* "It appears by the newspapers, that on the night of Tuesday, the 25th of February, 1812, three outside passengers were found dead on the roof of the Bath coach, from the inclemency of the weather. Neither money nor time is gained by exposing females and sickly people on the tops of coaches, in snow and rain, and to the hazard of their lives."—EDGEWORTH *on Wheel Carriages*, p. 146.

† The theory so readily adopted by our author from Edgeworth is shown to be a fallacy, as proved by H. H., on page 121, Vol. IV., of this Magazine.—Ed.

‡ If the writer of the above is correct, then high-wheeled chaises, carts, &c., must be *pleasant machines* for horses, and the man who put over four wheels to carriages, in the first place, was clearly guilty of exercising cruelty to animals.—Ed.

standing on four wheels, all as near together as they can possibly be set, and loaded similarly to the one represented here.



Suppose a coach so loaded to be traveling on fair even road, each wheel bearing in just proportion of the superincumbent burden; suddenly both the fore wheels drop into a water-gully, perhaps six inches deep, when a part, and not an inconsiderable part, of the load, which before rested on the hind wheels, is thrown on the fore wheels, whereby, when most disadvantageously circumstanced, as regards the horses, they are thus unfairly loaded. The fore wheels are no sooner raised out of this gully, and the weight again fairly divided on both axles, when, in another instant, the hind wheels drop into the same channel, and an equal part of the load which belonged to the fore wheels is thrown upon the hind wheels. The same weight alternately bearing first on the fore wheels and then on the hind wheels causes *double labor* to the horses; that is to say, the horses have, in crossing a gully, to draw the same—identically the same—weight *out of the gully twice*: first on the fore wheels, and then on the hind wheels; and the same *double operation* of the load takes place at every hole that may occur on either side of the coach. That this alternation of weight is very great is obvious to every person accustomed to ride on the tops of these coaches. The outside passengers may be said to be in one constant state of vacillation, not only sideways, but backward and forward; and every one of these backward and forward motions is the effect produced as above stated, which must ever be greater in proportion as the base of the coach is small, and as the column of the coach is high, and still more in proportion as weight is increased at the top of the column.

It may be said by coach-makers and by coach-masters that the above remarks are merely theoretical. I am, however, mistaken if it will not be admitted by persons conversant with mathematics that they amount to *proof* that the present construction and system of coaches is extremely unfavorable to the horses, and that the evil can be removed only by extending the base, and reducing the height of the column of the coach, or, in other words, by setting the wheels further apart, and by bringing down the load.

5. As my object is to produce a few plain and intelligible remarks, it is needless to enter into a discussion about the center of gravity. Every man of common sense knows that a wagon with a ton of lead in its bottom and a ton of hay upon the lead would travel very safely, whereas if the lead were on the top of the hay, it would be easily upset. Yet this is just the condition of one of our coaches: light wheels and light framework, a light body, with four, or at most six, persons in it, and over their heads at least a ton, no matter whether of lead or of human beings—twelve to sixteen persons; and not this only, for the roof is frequently covered with luggage, and that again crowded with passengers!

I hope to be excused for once more exclaiming against this irrational, absurd, and dangerous system of public conveyances, which calls loudly for the wise and judicious interference of the Legislature.

NEVER trouble trouble, until trouble troubles you.

## SPIRIT OF THE TIMES.—A COMEDY.

BY AN AMATEUR WRITER.

## DRAMATIS PERSONÆ.

**TIMOTHY.**—An ambitious and enterprising jour (hired for such), who has arrived at the conclusion that *now* is his time, therefore he has determined "to kick the old man" for higher wages on the coming Saturday night.

**BOSS.**—An old carriage-maker, who once believed himself master of his own shop, but latterly thinks he must have been mistaken, and perhaps merely dreaming all his life-time.

SCENE.—*New York City. Office in a Carriage-manufactory.*

[Enters Timothy, who comes for his weekly wages.]

**Boss** [adjusting his "specks" to his nose]. Well, young man, how much time have you made this week?

**Timothy** [with an air of importance]. Six days, I guess.

**Boss** [counting out and handing him \$12]. You will be on hand Monday morning, will you?

**Timothy** [straightening himself up]. I don't know about that. I can't work for \$12 a week any longer. I can't support my family on that, with bread at war and famine prices—want \$15 hereafter, and must have *that*, or I will quit.

**Boss** [thoughtfully]. I do not see how I can well afford to advance your wages. I want to get the work on hand along, but I cannot increase the charges to customers without driving them away. However, I will give you what you ask next week.

[Monday passes—Timothy *non est*. Tuesday morning he makes his appearance ten minutes past seven; Boss looks sour through his glasses, but dares not complain. Friday morning comes—Timothy is fifteen minutes behind time. Ten o'clock A. M. arrives.]

**Boss** [entering the paint room]. Will you be kind enough to hurry that coupé along? My customer is clamorous for it. [Exit Boss.]

**Timothy** [to a fellow-shopmate]. I wonder if that old fool thinks I am a-going to work my fingers off at twenty shillings a day. I won't do it. [Goes leisurely to work.]

**Boss** [Timothy entering the office on Saturday night for his second week's wages]. Sir! here are \$12.50. [Exit Timothy.]

[Time passes; another Saturday night comes around; Timothy enters the door, saying, I have made four days this week—want \$10 of you!]

**Boss** [agitated, hands out the money]. If you could not once support your *poor* family at \$12 the week, how will they get along for the coming week with *only* ten?

**Timothy** [indignantly]. That is none of your business. I am able to manage my own domestic affairs without your intermeddling. [Exit Timothy, in a rage, who, without further parley, goes to the paint room for his apron, and slamming the door after him, leaves the place, not even advising his employer of his intention to get a job elsewhere.]

*Such is—business in a carriage shop now!*

NOTE TO THE EDITOR (from the Boss above alluded to).—Can you tell me, Mr. Editor, why it is invariably the case that, when I increase the wages of my men, they are sure to lose more time than they ever did before? We leave our readers to answer.—Ed.

## Pen Illustrations of the Drafts.

## COMPASS-FRONT COUPÉ.

*Illustrated on Plate XXVIII.*

ON a small scale, this is the most aristocratic carriage that can be produced. The compass-front gives it a richness over all other styles. A continuation of the boot panel from the door point is a feature not generally introduced, but has a very pleasing effect when concaved in an easy and graceful manner. Imitation cane-work is getting to be quite general on the best class of carriages, and it being quite difficult, as well as expensive to put on, there is no probability of its ever getting too common.

X. Z.

## EXTENSION TOP BAROUCH.

*Illustrated on Plate XXIX.*

THE drawing from which our engraving is made was kindly communicated for the Magazine by Messrs. Bunce & Co., New Haven, Conn., and is original with Mr. C. H. Bunce, who writes us: "I do not know as any explanation is needed with the draft. It is simply an extension top barouch, with wings, a paneled body, round cornered front seat, roll-up top. We sometimes make them with a close back quarter. It is very light and roomy, for one or two horses, and termed a Light Sociable Barouch." We hope to hear from our friends soon again, and from any others who will put us in possession of good designs of the medium class of vehicles. It will afford us much pleasure to increase our variety for the forthcoming numbers, in accordance with the wishes of our friends.

## NEW YORK BOX-BUGGY.

*Illustrated on Plate XXX.*

JUST now the buggy we give is very popular with the New York public. It sold better last fall than any other. As may be seen, it is deep-sided, with a paneled seat, and is left quite open back of the seat, for the reception of packages. It is selling for about \$225.

## NEWPORT CART.

*Illustrated on Plate XXXI.*

WE do not offer this as particularly new, for it is not, but present it to the reader as something a little out of the ordinary line in American carriages. The axle works through the body, in which the springs, concealed, play. Some of these bodies are wicker-work, which, if we take our Paris cotemporary as authority, are all the rage now, and some are paneled, as in our example. Mr. Williams, of Mercer Street, New York, has disposed of a great number of these carts the past year. Their popularity is due, probably, more to a whim than any other consideration. They are great favorites with the visitors to Newport, R. I., during the watering season.

## Sparks from the Anvil.

### PLATING THE COUPÉ ROCKER.

ON Plate VI, of this Volume, the reader will find a very pretty design of a coupé. For those not very well skilled in carriage architecture, we have prepared the diagram which accompanies this article, and which is intended to show the manner of contracting a concave-fronted coupé, and applying the edge-plates or rocker-irons.

After the front pillars have been framed, it will be

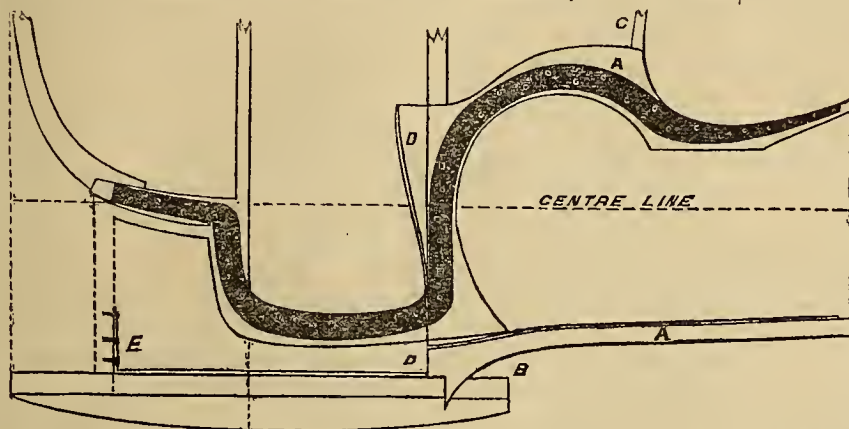

necessary to construct the front part, A, which, in this case, is done by using plank full five inches in thickness and thoroughly seasoned. Even then it will be found necessary to glue on a piece of plank sufficiently thick to make up the concave, B. The entire front is got out of a single piece, with the exception of the seat-pillar, C, which, in framing, is halved down as far as is needed to get in three screws. After these front pieces are framed into the front-pillars, the filling-pieces, D, must be fitted on to receive the edge-plates. These filling-pieces are intended merely to fill up the space on the front pillar caused by the lap of the front. From D, the filling-pieces should be tapered down, as shown in the diagram, to make the front and bottom side come even, so as to receive the edge-plates. The outside of these front pieces, in finishing, should be paneled over, so as to hide all the joints created in making up the concave.

The edge-plates used for this job should be at least  $2\frac{1}{2}$  ×  $\frac{1}{2}$  inch thick, and well secured to the frame with No. 20 screws, three inches apart. There should be about three bolts through the front-pillar, filling-piece, and rocker-plates, to hold the whole firmly together. At E is shown the turn in the rocker-plate, on the back-bar, to better secure the body together. In this example the body is supposed to be 3 feet 6 inches on the seat, and 28 inches in front, which may be ascertained by measuring from the center line.

### IRON IN NEW YORK.

THE remarkable cheapness and ample production of British iron are not secured only or mainly through the superiority of British skill and experience, nor yet through the abundance and relative cheapness of British capital. Common iron is made cheap in Great Britain, not so much for any of these causes, nor yet because of the superiority of British ores; but because the density of population and activity of business in the "tight little isle"

have caused it to be so gridironed and chequered with canals and railroads that each ore-bed is the close neighbor of every other, and the mixture of diverse ores—one of the bases of successful iron-making—is effected there far more cheaply and generally than elsewhere; while ore, coal and lime are likewise concentrated at each furnace at a trifling cost. Were our country cut up by railroads into squares and oblongs no larger than those which separate the iron tracks traversing Great Britain, our production of iron would soon be largely increased, while its cost would be diminished. And, on the other hand, the concentration of diverse ores and other materials largely required in iron making is destined largely to increase the business and the profits of our railroads.

These truths are illustrated by what is now occurring at the little hamlet of Copake Station, on the Harlem Railroad, 108 miles north of our city—a point where that road closely skirts the mountainous elevations and valleys which form the Berkshire section of Massachusetts. Superior ore has here been mined, and, in a small way, converted into an excellent quality of charcoal iron for a couple of generations; but, in the absence of railroads, it was impossible to extend the production. To bring mineral coal to the ore would cost too much; to increase considerably the production of charcoal iron would soon dis-

forest the adjacent hills and ravines, thus increasing the cost of the product to a point beyond the price which can be obtained for it. Hence the production was, under the old state of things, not only inconsiderable, but capricious, being governed not only by the fluctuations of the iron market, but by the facility of procuring charcoal.

But the railroad has changed all this. It crosses the ore-bed directly at the station, so that cars may be loaded from it by wheelbarrows while standing on the side-switch. The ore (a brown hematite) is of a very superior quality, closely resembling that of the famous Salisbury bed in Connecticut, from which it is but six miles distant. The iron made from it on the location was for many years supplied to the Springfield Armory for the manufacture of gun-barrels—a service to which only the finest and toughest iron is adequate.

A company has recently purchased this ore-bed, or the greater part of it, and purposes to devote its energies entirely—for the present, at least—to the supply of ores by rail to those who require them. To this end, they have not only the Harlem Road directly across their bed, but they reach the Hudson River at Hudson—a point 18 miles distant by carriage, but 35 by the Harlem and the Berkshire Railroads. They are now preparing to mine and send off 100,000 tons of ore per annum, and they calculate that their bed—underlying 45 acres not far below the surface, and proved to be in some parts 35 feet in depth—will supply that amount steadily for fifty years; while the demand for it at a price which will yield at least \$1 per ton net for the ore at present very far exceeds the capacity to supply it. To that demand all the furnaces along the Hudson would gladly contribute. But the arrangements now in progress will speedily secure a very large and constantly increasing product, giving extensive employment to labor, affording a market for the agricultural products of the vicinage, and largely increasing the transportation and the income of railroads not hitherto overburdened with freight. It is probable that thirty

thousand tons of choice iron, worth at least a million of dollars, may ere long be added to our country's annual product from the new and enlarged development given to this single ore-bed.

This is but a sample of what, under the novel stimulus of high prices, and an eager demand for iron, is proceeding all over the loyal States. It is said that 200,000 tons of iron ore have this year been brought down from the Lake Superior mines to Marquette; as more would have been, had the capacity of the railroad permitted. Such is the demand for these ores, to be smelted with others, at the furnaces of Pennsylvania and other States, that a new railroad, on the far shorter route from the Superior mines to Little Bay de Noquet, is now being constructed, and is expected to be open for traffic next Spring. This country should be a large exporter of iron within the next ten years.—*Tribune*.

## Paint Room.

### COMPOSITION OF PAINTS.

BY H. HARPER.

(Continued from Page 107.)

The cost of making varnish thirty years ago, contrasted with the present mode—The author "can't see" why English varnish should be superior to ours, when both are made from American productions—The process of manufacturing varnishes detailed—The great importance of dealing with honest manufacturers, and taking *The New York Coach-maker's Magazine*, illustrated by a case in point—Dishonest dealers, don't patronize "the organ" of the craft—It should not be expected that either Jew or Gentile will make and sell varnishes at a loss; whatever may be their pretensions.

THE process of manufacturing Copal Varnish in these days, with the expectation of making it serviceable to the consumer, by manufacturing for his own use, would be almost as useless as manufacturing white-lead, or any other article that requires a large capital to carry on the business profitably. Thirty years ago it was quite different. Then the painter could not carry on his trade well without manufacturing for himself as much at a time as he would want to use for two or three years. At that time paint dealers would hire a varnish maker to come to their place of business and make as much varnish as the market demanded for a certain length of time, to the extent of their limited means. This way of doing business could not be carried on long without suggesting to the employed the great advantages derived from permanent location and suitable conveniences for melting the gum, and preparing and mixing the oil and turpentine with the gum, after it was melted; together with other operations necessary for fitting the varnish ready for use. By doing it on a large scale, the manufacturer could afford to sell it much cheaper, and, at the same time, could so arrange his business that the painter would be supplied at all times with an article that had age, which is an indispensable qualification in varnish.

I should deem the subject entirely useless if nothing could be derived from it more than to enable the operator to make a little varnish, which, at best, would cost him more than to buy the same, that was well matured and ready for use. In another light, the subject is of great importance. According to some painters—yes, a great many—a certain kind of varnish has a national rep-

utation, like the Berkshires, Short Horned Durhams, &c. As for myself (on account of my obtuse faculty of discrimination, or some other cause), I never could accord the superiority to English varnish that a great many others do. But when our own manufacturers will make an article which they call "imitation English," and rank it among their most costly varnishes, I am left so much in doubt about the correctness of my own judgment, that it would be improper to urge it upon others, without first giving as full reasons as I am capable of doing for the same. If it is superior, that superiority must be derived alone from its transit across the water, for in every other particular we are even with them as to manufacturing. Our process of melting the gum, as I have been told, is the same as that followed by the large English manufacturers. The gum is to both countries a foreign product. The oil is made from American flax-seed mostly, and in the same way. The turpentine, in the days of Carolina's prosperity, was her product; and, taking all these facts into consideration, it is "strange that such difference should be twixt tweedle-dum and tweedle-dee."

Now, we will give some plain, simple facts as to the way we formerly made copal varnish—which, in substance, is the same as now practiced, only with improved apparatus—that may help us to judge on the subject; at least, it will show that there is no mystery about it.

A varnish-kettle, made of copper, and in the shape of an egg, with the small end taken off for a cover to the kettle, was used. The large end of the kettle, which came in contact with the fire, was thicker than the other parts. These were generally made to hold from four to six gallons. The cover, made to fit tight, had a hole in the top of about one-half inch in diameter, through which was inserted an iron rod to stir the gum with and keep it from adhering to the kettle. Some put lead in the kettle, which would settle to the bottom and prevent the gum from coming in contact therewith. Others, again, would mix broken glass among the gum, and others used neither. The gum copal is sometimes selected, the amber-colored from the white, the former being considered the best. About three pounds is enough to melt in a large kettle at one time. A fire was prepared of charcoal in a suitable iron furnace to receive the varnish-kettle, and not allow too much heat up the side of the kettle, so as to communicate with the vapor of the melting gum, as it would ignite and set the gum on fire. When the gum in the kettle is over the fire, it is necessary to constantly stir it with the iron going through the cover, when it commences melting, as it will foam up so as nearly to fill the kettle. The stirring reduces the froth. At this stage it is usual to put in camphor gum at the aperture in the cover, to the amount of about one-fourth of an ounce to one batch of melting. This helps the gum to melt or dissolve. The difficulty that now presents itself, is to get all the gum melted, and not allow it over the fire a moment longer than is necessary for that purpose, for fear of its burning so as to color the varnish. This stage is ascertained by the use of the rod. As soon as the gum is all melted, the foaming which has been going on from the commencement will have entirely subsided, and the gum is then in a liquid state at the bottom of the kettle. Remove it immediately from the fire. During the process of melting the gum, the oil to be mixed with it must also be heated about as hot as it will bear without coloring it. This oil should have been previously prepared for drying

in the usual way by boiling, without coloring it any more than can be helped. While it is hot, turn about one quart by degrees into the melted copal, taking care that it does not foam. Stir it well with the rod until it has become so cool that the turpentine may be mixed without creating too much vapor, and mix only enough to keep it from becoming wax after cooling, and so that more turpentine will dissolve it. Varnish is simply a glazing put over the painter's work when finishing. This glazing is made with oil and copal gum held in solution by the use of turpentine in the process that I have here described.

Perhaps the young varnish-maker, who is used to the modern improvement in our large manufacturing establishments, may smile at the rather primitive way which I have described; but this was the mode practised before these large establishments were in existence, and, in substance, the present mode is the same. Of course I could suggest new improvements, particularly in the preparation of the oil. I have no doubt the English have generally adopted a different mode from ours in preparing their varnishes, as their lasting varnish is longer than ours in drying. We have believed—and it has been said so before in this Magazine—that the addition of dryers to oil, in all cases, rendered it more susceptible to the action of oxygen, which would account for slow drying varnish—that is, the oil in the varnish—lasting the longest. The action of the oxygen on the oil destroys the gloss and injures the looks; yet, in fact, the glazing which is formed by the gum remains, as the oxygen will act on it for a much longer time. This is the only difference that I can see between the American and English varnish; and the appearance of the latter favors that conclusion, for it is thinner and more limpid than the former.

These details—as we said on the start—are of very little use to the carriage-maker in manufacturing varnish, but in another sense we think they are of great importance. They suggest to his mind how easy it is to form a glazing out of some cheaper substance which will for a time deceive him. If there ever was necessity for dealing with an honest man in manufacturing that we cannot do without, *it is that of an honest varnish manufacturer*. If he knows enough to manufacture varnish, he knows enough to cheat you in some way, if so disposed. Our judgment, merely by inspecting a sample, is of little avail. Much more can be gained by one tolerably well posted, by talking with the proprietor. If he is bound to cheat, he will be pretty sure to fortify his argument by something that you know is false. We need not expect that we are going to be cheated always with an inferior quality of varnish; such a game would soon be played out. These operators have the best field for trade in sections where *THE NEW YORK COACH-MAKER'S MAGAZINE* is not generally taken, and they improve it to my certain knowledge.

One of these fellows came into my shop, three years ago, soliciting orders for varnish. I told him that I had used some very good varnish, made in Boston. The reply was quickly, "Ah, put you cannot git any more das farnis, dey have proke down." I asked him if his firm advertised in *THE NEW YORK COACH-MAKER'S MAGAZINE*, and other questions necessary to satisfy my mind as to his credibility. "He did not want any petter advertisement than the quality of his farnis,"—and his reply to other questions satisfied me that he was not the man to deal with. Soon after I learned that one of his

firm had been exposed in an attempt at bribing a railroad superintendent to take a large bill of his varnish.

I naturally had a curiosity to know how those came out who traded with him. In my own locality, among two who took a supply, one lot was good, the other was a poor quality for the price. The one who had the good, ordered another bill, which was good with some exceptions; for which the manufacturer would be excused under the circumstances. Further inquiry through the country showed that those who had bought, at last had come to the conclusion that their casks looked small, and some of them measured their varnish. In every instance they found out they had received short measure. The mode of operation seemed to be, to cheat in quality, wherever it could be done, those who never would know good from poor; and, with the better informed, to cheat in quantity, so that it would make a percentage sufficient to pay for soliciting customers, and a profit. This is but one phase in deceptive operations to which we are subjected, all of which we might escape by taking a prudent and honest course on our part. We say honest, because it is very well understood that if we get deceived in buying we also deceive in selling the same article; therefore, if we do not use the necessary precaution, we are no better than the first rogue.

We have an organ for the craft, that is quite sure to put us on our guard against such deception; at least, that it cannot be carried on by a systematic course, for any length of time. An honest manufacturer is glad to bring his goods to notice through that organ, and pays for it. He has embarked in a business that must last for years, and depends entirely on his good name for success. Is that man to be placed by the side of the trickster who is ashamed to show his colors by an advertisement, but depends on the much more expensive way of seeking out his victim? There is nothing more certain, than that varnish cannot be made without cost, nor can it be sold without expense, and all this expense must come out of the consumer. Is it wise to believe that the wandering man, who is taking the most expensive way to dispose of his varnish, is going to give us any better trade than the man, who has made his business public, as well as established his character and legitimately put himself on record by an advertisement in our own organ?

The class of men who are so deceived, as we have said, know little about any such organ, and it is somewhat amusing to see how little they know about what is going on among the members of their own craft. They think that they are the only victims, and perhaps that is only a mistake. The inducements held out for them to buy were so fair! "They need not take it if it did not give satisfaction!" Suppose they get 17 gallons for 20, and use some without measuring, as they generally do, and finally conclude not to take the cask? Well, then, the matter must be settled up, and of course it will be fair to pay for what has been used! That conclusion is arrived at by what is left! Why there is a clear gain of the value of 3 gallons—besides transportation to market—which is a good operation for the manufacturer. That will pay for hunting up another victim who is equally ignorant about what is going on. Now, I can come to no other conclusion than that the man who offers his skill and service to the public as an artizan, and will not contribute his mite to support an organ that is calculated to advance his own interest, and through him the interest of

his customers, is not over honest, nor wise, to say the least of it. The same may be said of the man who has all the needed information, and does not judiciously act upon it.

If we have failed to make varnish makers of the readers of this article—as we partly suspect we have—yet it is hoped that we have given some hints that will be useful to varnish buyers. One thing more we will add—don't expect that a Jew or Gentile is going to make good varnish and sell it to you without a profit, *even if he tells you so*. He will not do it, and this great anxiety on our part to get it *very* cheap is generally met with some kind of a dodge, so that we are no great gainers, after all, by that kind of sharpness.

(To be continued.)

## Trimming Room.

### GREAT RISE IN THE PRICE OF TRIMMINGS.

IN no department of the carriage-maker's business has there been so steadily an advance in price, as in the trimmings, during the past year. Nor have we ever known before so rich a quality of goods in demand. Where luxury in this respect will stop is a difficult point to decide, and perhaps need not trouble the manufacturer's head. A detailed increase in prices, however, may interest the reader, and show that it costs something to carry on an extensive business, "about these days."

We begin by comparing the prices paid for cloth in March last with the present rates: Body cloth was then quoted as being \$2 @ \$3.50; the same article now costs \$3.75 @ \$4.50 to \$5. Enamelled cloth (say 4 qrs. wide) has gone up from 90c. to \$1.50. Picked hair, from 38c. to 50c. per pound. Enamelled top leather, from 21c. to 27c. Velvet carpets, from \$1.75 to \$2.75. Oil cloths, from 44c. @ 50c. to 60c. @ 80c. These are but a small enumeration of the prices charged for material used in lining carriages, all of which prove that ten months has added full 33 per cent. to the costs, as formerly paid. Let any one of our readers satisfy himself by comparing the Price Current list of last Spring, with the table of prices accompanying this number, and convince his own mind on this subject, and see how much necessity there is for getting better prices for carriages. Many manufacturers in this city are now charging \$350 for top buggies, and our country friends must advance too, or suffer. We are more urgent for this comparison because we think manufacturers generally are too eagerly selling without due regard to the expense of manufacture. It may be well to remember in this connection that a carriage costing \$275 cannot be sold for a less sum. A little figuring in these times will prove beneficial, and perhaps keep the sheriff off a spell longer, than by "going it blind," as we fear some are. A little arithmetic will be found especially useful in a carriage shop.

### REVIEW OF THE FASHIONS.

ON page 11 of this Volume, we gave our readers the Spring style of trimming buggies, a few changes in which it will be necessary to note here. Instead of inserting welts in the fronts of cushions and falls, the general practice is to insert a cord between the cloth and lining, and stitch along the edges on both sides. This gives a neat finish to them. The festoon fringes, which formerly took

the place of sun curtains, have been entirely done away with, and nothing else supplies their place now. In other respects the fashions remain unchanged.

Before we leave this subject we will add a few observations respecting the taste shown by many manufacturers in selecting colors. We often see red carpets put into carriages, lined with blue cloth, and other equally absurdly selected contrasts, going to exhibit bad taste in somebody. There is no excuse for this, unless it be on the outskirts of civilization, where there is no opportunity for exercising judgment. Need we say that a blue lining to be in taste, demands to match a carpet in which blue predominates? Why not, gentlemen, proceed in selecting your trimmings a little more after the rules common sense would dictate in other affairs of life? A little care will greatly improve the looks of your carriages. Try it and see.

## Editor's Work-bench.

### GREETINGS.

To ALL our readers, A happy New Year!

A review of the past and present situation of business gives us cause for great thankfulness to the Supreme Author of all blessings. Although a suicidal war has been carried on in sections of our country for more than two years, still here in the North, where our enemies predicted ruin, prosperity attends our labor. Our fields have yielded abundance, and our workshops have not been idle. The excise tax, once thought a terrible thing, seems to trouble none of us much. It is cheerfully paid as the month rolls around. "Greenbacks" as "thick as leaves in Vallambrosa" are scattered in every direction, and even in Secessia are appreciated. Our enemies have become disheartened because of failure in all their recent battles, and recognition from Europe apparently is far remote. All these things should make us truly thankful.

Turning to our own special business, we, as coach-makers, ought surely to be thankful. Here in mid-winter—an unusual thing—our shops have as much or more business than we can do, at good prices. The greatest drawback is in the scarcity of skilled labor. This, however, is the natural consequence of war, and must be expected. With the return of peace these difficulties will doubtless be obviated. As long as our customers remain, and are willing to "pay the coach-maker" living prices—though fabulous—let us labor on, and rejoice together.

But the future—that we are told is full of encouragement—that with the subjection of the rebels, and universal freedom prevailing in all our borders, we are destined to revolutionize the world—that our prosperity will be the death-blow of oppression everywhere—that Liberty will reign in lands where peoples have already too long pined in political chains. Fellow-craftsmen, comrades in trials, let us nerve ourselves to fight bravely the great battle of life together. Another year will, in all



probability, see our Temple of Liberty completed, and that of Janus closed—we trust forever.

### EDITORIAL PERPLEXITIES.

If an individual wishes "to get into business up to his eyes," just let him start a Magazine, and edit it himself. He will very soon discover that he is "getting into hot water" beyond relief. Although he may gather around him armies of professed friends, as long as sunshine prevails, when the storm comes, most of them depart like the morning dew. The chair editorial presents one of the best schools for studying human nature in existence. There *lights and shades* present themselves in diversified succession, the shadows standing out in bold relief. For one encouraging word that an editor receives he will be very apt to get five fault-finding. No matter how hard he studies to please, he, in the end, finds he cannot do it, and that difficulties multiply as he tries.

Perhaps, as publisher, he trusts to the honor of an old subscriber, and sends his publication some six months beyond the period paid for; but when he does call, through an agent, he gets a note as follows: "Mr. — has taken a notion not to pay for any periodical in advance. I therefore return to you his bill. . . . The fact is, some people do not appreciate your benevolent design in publishing the Magazine. I suppose 'that's what's the matter.'" Nothing more than a whim dictated the above course of conduct, and doubtless the greater loss is with the subscriber. That, however, does not relieve the publisher's mind of perplexity, nor pay his printer's bills.

At another time an *enterprising* correspondent sends him a letter as follows: "Dear sir, please send to my address a specimen copy of your, 'The New York Coach-maker's Monthly Magazine.' I saw a notice of it in an agricultural paper, and, as I am one of the 'craft,' I desire to sustain all such enterprises." Such letters, be it understood, always set us to figuring up how many *such* members of the craft it would take to sustain *our* enterprise—in war times. We then write him a letter, telling on what terms we can send him a "specimen copy." Need we say that cuts the matter short? *If* we only had the money for the specimen numbers we scattered over the country *when we were green at publishing*, we could well afford to give away numbers now. But *that game is up*.

As editor of a specialty, he will be told by a country subscriber: "I think your Magazine would be more acceptable to your country subscribers if you would give them more designs for buggies," while a city carriage-maker wants more heavy vehicles to suit *his* business. Now, we labor assiduously to satisfy our patrons, and yet we fear we labor in vain. We give each month one light, one medium, and one heavy design. What can we

do better? Surely our friends ought to be satisfied with this — not selfishly expect us to act only to please them, to the total neglect of others who have just as strong claims upon us in an opposite direction. We need some liberality of sentiment; as well as pecuniary assistance, to produce and sustain *this* enterprise, and it is only owing to much sacrifice on our part, during the past two years, that the craft still have a live organ. Whether it lives beyond next May; or not, rests upon the sacrifices others are willing to make to sustain it the coming four months.

### CANADIAN EXHIBITION OF CARRIAGES AND MATERIALS.

A PROVINCIAL FAIR was held at Kingston, C. W., in September last. The following articles, connected with carriage-making, were awarded the prizes, as stated below:

Best two-horse pleasure carriage, Hart & Son, Picton, \$12; second best, A. Titus, Farmersville, \$7. Best one-horse pleasure carriage, Fralic, Bros., Picton, \$8; second best, S. Lake, Newburgh, \$4. Best double-seated buggy, Hart & Son, Picton, \$8; second best, S. Lake, Newburgh, \$4. Best one-horse buggy, Fralic, Bros., Picton, \$7. Best trotting sulky, S. Lake, Newburgh, who also received the prize (\$3) for the second best. Best two-horse pleasure sleigh, Hart & Son, Picton, \$10; second best, to the same party, \$6. Best one-horse pleasure sleigh, Fralic, Bros., Picton, \$8; second best do., S. Lake, Newburgh, \$3. Best two pairs of carriage hubs, John Eakin, Markham, \$3; second best do., to the same, \$2. Best dozen machine-turned carriage spokes, T. C. Saunders, St. Catharines, \$3 and a diploma. Best two pairs of carriage rims, R. McKinley & Co., St. Catharines, \$2; second best do., Fralic, Bros., Picton, \$1. Best half a dozen bent-shafts, R. McKinley & Co., St. Catharines; second best do., Fralic, Bros., Picton, \$2. Best bows for tops (two sets), R. McKinley & Co., St. Catharines, \$3. Best wrought iron axle, A. C. Chewett & Co., Kingston, \$3; second best do., Byers & Matthews, Gananogue, \$2.

The following were entered as "Extras:"—Assortment of spokes for wagons, buggies and sulkies, Thomas C. Saunders, St. Catharines, \$2; Assortment of bent stuff for wagons, buggies and sleighs, R. McKinley & Co., St. Catharines, \$5. Also, for two sets of bent rims for buggies, \$2; for two sets of wagon rims, \$2; for two sets of sulky rims, \$2—all to R. McKinley & Co., St. Catharines. Best buggy seat rails, Fralic, Bros., Picton, \$2; best carriage hub and axle, all iron, A. C. Chewett & Co., Kingston, \$3 and a diploma. The judges, M. Donovan, of Whitby; E. Cooney, of Cobourg, and J. Falconer, of Kingston, express regret that they found so limited an assortment of vehicles in the exhibition, which, as the reader will observe, was confined to two or three houses. We

think an increase in the amount of the rewards would have a good effect. Judging from our own observations last spring, we are led to conclude that the best manufacturers of carriages in the Province, were not represented in the late fair.

We have previously noticed the bent and turned stuffs of our friends, R. McKinley & Co., at St. Catharines. In addition to much obtained from the States, they have woods of the very best quality, of Canadian growth, which are bent and sold cheaper than the same articles can be obtained from this side of the line. Our friends throughout the Canadas will find the St. Catharines firm, in all respects, gentlemen with whom it is pleasant to deal.

#### EDITORIAL CHIPS AND SHAVINGS.

**THE BEST TIME TO CUT TIMBER.**—A correspondent of the *Boston Recorder* says: A short time since I saw a statement on this subject in a newspaper. I wish to give my own experience and observation for over fifty years, constantly working and using most all kinds of timber, more especially oak, ash, and walnut. I have learned, by dear experience, for I have lost much by the effects of worms in my timber, and have found when timber may be cut and have no worms, or powder-post, as it is called. Cut timber from the middle of September to the middle of December, and you cannot find a worm in it. October and November are perhaps the best months, and sure to avoid the worms.

**ANOTHER STEAM-CARRIAGE.**—S. H. Roper, of Roxbury, Massachusetts, has recently invented and put in operation a steam-wagon for common roads. It is hung on four wheels, and has a sixteen-inch boiler in the rear, with a lever for regulating the steam and speed, extending over the seat in front. The furnace is beneath the boiler, and the water-tank in rear of both. The steam-gauge is on a level with the driver, who, by a glance, can ascertain the amount of steam pressure. The machine is of two-horse power, carrying two passengers besides the driver. Coal for a day is stowed under the seat, and the speed of a horse is obtained at the cost of one cent a mile. The whole machine weighs only 700 pounds.

**FACTS ABOUT RAILROAD SPEED.**—A railroad car moves about seventy-four feet, or nearly twice its own length, in a second. At this velocity the locomotive driving-wheel, six feet in diameter, makes four revolutions in a second, the piston-rod thus traversing the cylinder eight times. If a horse and carriage should approach and cross a track at the rate of six miles an hour, an express train approaching at the moment would move toward it two hundred and fifty-seven feet while it was in the act of crossing; if the horse moved no faster than a walk, the train would move toward it more than five hundred feet, which fact accounts for the many accidents at such points. When the locomotive-whistle is opened at the post eighty rods from the crossing, the train will advance near one hundred feet before the sound of the whistle traverses the distance to, and is heard at the crossing.

**THE NEW TRAFFIC REGULATIONS FOR THE CITY OF LONDON.**—Between 9 A. M. and 6 P. M., no vehicle with more than four horses is to be allowed in the streets.

Coals, beer, wine, or other liquids, are not to be delivered in twenty-four principal streets except very early in the morning or after five in the evening. The sale of vegetables, fish, fruit, or other articles carried in any vehicles for sale, is also forbidden in the same streets between 9 A. M. and 6 P. M. Wagons, when loading, are to be placed parallel with the curb-stone of the foot-paths. Many other regulations of a similar character have also been established.

**MINERAL PAINTS OF CALIFORNIA.**—The locality of our native paints is only about two miles from the town of Martinez. The paint deposits are found on the banks of El Hambre Creek, at the foot of a high hill, between the houses of Dr. J. Strentzel and M. R. Barber, and on the land of the latter gentleman. They lie in ledges extending into the earth under the hill, the outcroppings of which alone are visible on the surface of the ground near the aforesaid creek. These ledges vary from ten to twenty feet in width, and are of unknown length and indefinite depth, perhaps miles in extent. At least four of the principal or primary colors have been found contained in the earths dug out of these ledges, namely, red, yellow, green, and blue.

#### LITERARY NOTICES.

**THE ATLANTIC MONTHLY**, for December, being the concluding number of the XIIth volume, has been received. The XIIIth volume commences with the January number, 1864. The publishers say that the work has attained a circulation and prosperity never equalled by any American Magazine of its class. This success enables its conductors to employ the most eminent talent in the country as contributors. They promise that the forthcoming volume shall in no wise be inferior to those previously issued, which is saying a great deal respecting a work of such intrinsic merit as this universal favorite. Subscriptions \$3 a year, postage paid. Address Ticknor & Fields, Boston, Massachusetts.

Some person in Berlin, Prussia, has sent us the *Deutsche illustrierte allgemeine Wagenbau-Zeitung herausgegeben von Georg Meitinger, Kastenfabrikant und Wagenbaumeister in Munchen*. It is a sheet of eight pages, the exact size of ours, with about four carriage illustrations in each number, the greater part of which are copied from the *Mercure Universel*. Our ignorance of the German language prevents our judging of the value of its literary contents; but the typographical execution is very creditable to all concerned. This publication is evidently another attempt to follow where our Magazine has led the way. May its success exceed that of our late English cotemporary. We hail everything of this kind as a benefit to art.

### The Coach-maker's Letter-box.

LETTER FROM WISCONSIN.

BERLIN, Dec. 7th, 1863.

MR. EDITOR,—The ideas you published on motive-power, were supposed by me, at the time I wrote them, to be original, but from an examination of the articles which you are now publishing, and from a more close inspection of Mr. Anstice's ideas which you had com-

menced publishing when I began, I see that I have not as much claim as I had supposed to originality. I had never seen any publication on the subject before the first one alluded to. It seems now that I have followed in their track as far as they were correct, and where they were incorrect I am glad to find that I have deviated.

Mr. Ansticè fell into an error in calculating the lever-power of a small wheel in ascending an inclined plane, as being equal to that of a larger one. Mr. Fry, in the present table of lever-power, in different sized wheels, so far appears to have fallen into the same error, by not making a calculation in reference to different sized axles. If he had done so, the question about large and small axles would have been definitely settled long ago. I also see that in the article referred to, the heft of large wheels is urged as the main objection against them. The effect that raising the draught has upon the horse, as the article which you now have will explain, will come in opportunely with the subject [see on p. 114]. It is refreshing to me to have these sound philosophic principles of old authors brought to light. What a public benefit it would have been, if the craft could have had the principles—at the time they were conceived—spread before them, so that they could analyze and reflect upon them. Calculated from a stand-point of dollars and cents, every man in every civilized part of the globe where wheel-carriages have been used, who has come upon and gone off from the stage of action since that time, could have afforded, through the business part of their lives, to have subscribed and paid yearly for similar publications to your Magazine, and still would have been the gainers. Such are the glorious effects gained by the introduction of one single philosophical truth to the world.

Yours, &c., HENRY HARPER.

#### FOREIGN IMPROVEMENTS IN CARRIAGES.

**HEARSES AND FUNERAL CARRIAGES.**—Nov. 28, 1862. J. Cresswell and E. T. Greves, Birmingham. In carrying out this invention, the patentees construct a hearse with several compartments, the number found convenient being about twelve. The hearse is thus arranged:—In the fore part of the carriage, over the front wheels, are four compartments—two, one over the other, on either side; these are closed from the side of the hearse by suitable flap doors or drapery. On the rear part of the carriage are six similar compartments, so that the hearse is of a length to contain two coffins laid end to end; the compartments in the rear part of the carriage are closed at the back. By cranking the rear axle of the carriage, space is obtained for two more compartments hung from the body of the rear part of the carriage, thus making one hearse to contain twelve corpses in separate compartments. The improvements in funeral carriages consist in adapting one carriage to the conveyance of several parties of mourners separately; and with this view the patentees propose to construct a long carriage, similar to an omnibus, but divided inside into two or more compartments, which can be closed by sliding doors, or curtains, or in any other similar manner. This carriage is entered from the back, a passage running up the centre, and is lighted at the sides. The first party of mourners passes up the carriage to the compartment at the front end, and closes the sliding door or curtain. A second party follows, and the second compartment is closed, and so on until the

several compartments of the carriage are filled. The last to enter is, of course, the first to come out, and in the order in which the corpses may have been placed in the hearse the mourners are to be seated in the carriage, so that no confusion can arise. Seats for the bearers and attendants are provided on the outside of this carriage, behind the driver's seat.

**CARRIAGE AXLES.**—Dec. 6, 1863. R. McClintock, Dublin. The objects of this invention are to facilitate the fixing and removal of the wheels, and to diminish friction. Near the outer end of the journal of the axle, the inventor removes a portion from the circumference thereof, and places a split flanged ring or stop in the portion so diminished in circumference; the halves of this ring are kept together by an elastic band, which lies in a circular recess cut on the ring. Over this ring, and on the end of the journal of the axle, made square, he places a cap with a broad flange. This cap is secured by a bolt with a thread-cut end passing through a portion of it, and through the flange of, or secured by, one of the halves of the ring. A nut, guarded by a movable button, is screwed over the outer end of the bolt of the wheel. The cap and stop lie in a recess hollowed out in the boss or nave. To facilitate and insure the fixing of the parts, he sometimes causes a tongue to project from the stop and enter a hole bored for its reception in the non-removed portion of the journal. To lubricate the axle, he applies an oil-cup to the collar of the axle, from which the oil flows through a channel made for the purpose, and finds its way between the journal and the axle-box. He prefers to form grooves or channels around the journal. *Patent abandoned.*

#### AMERICAN PATENTED INVENTIONS.

**Aug. 25. BODY LOOPS FOR CARRIAGES.**—Chauncey H. Girard, of Troy, N. Y., assignor to David A. Burr, of Washington, D. C., (ante-dated, Aug. 19, 1863): I claim the use of a metallic bi-angulate clasp socket, C, in combination with a body-loop, B, a metallic compressing clamp, D, and a screw bolt, E, when arranged substantially in the manner herein set forth; I also claim the arrangement of the leveled faces of the lower edges of the sides, *aa*, of the clamping socket, C, in combination with the beveled edges of the embracing flanges, *bb*, of the clamp, D, when said socket, C, and clamp, D, are combined with a screw bolt, E, substantially in the manner and for the purpose set forth.

**WHIFFLE-TREE.**—John F. Ward, of Philipsburg, N. Y.: I claim the end of the pipe, A, with its hands, *l*, and recesses *pp*, or their equivalents, and packing, B, when applied to the spherical interior of the socket *a*, of an adjacent pipe, A, substantially as and for the purpose herein set forth.

**Sept. 1. ATTACHING BREECHING TO THILLS OF VEHICLES.**—La Roy N. Leslie and Thurston Richardson, of Leominster, Mass., (ante-dated, Nov. 19th, 1862): We claim *First*, constructing a breeching hook with a spring lever placed in or at its opening, and turning upon a pivot or fulcrum, so as to operate substantially as hereinabove described. We also claim constructing the spring lever with right-angular arms, working close or nearly close up to the bow of the breeching hook, substantially as described and for the purposes specified.

**WHIFFLE-TREE.**—Reuben Rolph, of Coventry, N. Y., (ante-dated Oct. 26, 1862): I claim the pivoted bar or rods, *EE*, in connection with the shaft, E, provided with the cams *hh*, the above parts being applied to the whiffle-tree, B, and arranged with suitable springs, substantially as shown for the purpose set forth. I further claim the employment or use of the straps, G, H, when attached to the whiffle-tree, B, and arranged relatively with the crank, *l*, of the shaft, E, as shown for the purpose specified.

## CURRENT PRICES FOR CARRIAGE MATERIALS.

NEW YORK, December 24th, 1863.

Apron hooks and rings, per gross, \$1.25.  
 Axle-clips, according to length, per dozen, 75c. a \$1.  
 Axles, plain taper, from  $\frac{3}{4}$  to 1 in., \$5;  $1\frac{1}{2}$  in., \$6;  $1\frac{1}{4}$  in., \$6.50.  
 Do. Swelled taper, 1 in. and under, \$5.50;  $1\frac{1}{2}$  in., \$6;  $1\frac{1}{4}$  in., \$6.75;  $1\frac{3}{4}$  in., \$8.75;  $1\frac{1}{2}$  in., \$10.25.  
 ☞ These are a superior axle, and more frequently called for than any others.  
 Do. case-hardened, half-patent, \$7; do. \$8; do. \$8.50.  
 Bands, plated rim, under 3 in., \$1.75; over 3 in., \$2.  
 Do. Mail patent, \$2.50 a \$3.25.  
 Do. galvanized,  $3\frac{1}{2}$  in. and under, \$1; larger, \$1 a \$2.  
 Basket wood imitations, per foot, 88c.  
 ☞ When sent by express, \$2 for a lining board to a panel of 12 ft.  
 Bent poles, each \$1.12 $\frac{1}{2}$ .  
 Do. rims, under  $1\frac{1}{2}$  in., \$2 per set; extra hickory, \$2.50.  
 Do. seat rails, 44c. each, or \$4.50 per doz.  
 Do. shafts, \$6.  
 Bows, per set, light, 85c.; heavy, \$1.12.  
 Bolts, Philadelphia, add 20 per cent. to printed list.  
 Do. T, per 100, \$3 a \$3.50.  
 Do. tire, \$1.25 a \$1.80 a \$2.40, according to size.  
 Buckram, per yard, 30c.  
 Buckles, per gross, 88c. a \$1.25.  
 Burlap, per yard, 25c.  
 Buttons, japanned, per paper, 15c.; per large gross, \$1.50.  
 Carriage-parts, buggy, carved, \$4.  
 Carpets, Brussels, per yard, \$2; velvet, \$2.75; oil-cloth, 60c. a 80c.  
 Castings, malleable iron, per lb, 15c.  
 Clip-kingbolts, each, 35c.  
 Cloths, body, \$3.75 a \$4.50; lining, \$2.25 a \$3.25. (See *Enameled*.)  
 ☞ A Union cloth, made expressly for carriages, and warranted not to fade, can be furnished for \$2 a \$2.25 per yard.  
 Cord, seaming, per lb, 25c.; netting, per yard, 5c.  
 Cotelines, per yard, \$6 a \$8.  
 Curtain frames, per dozen, \$1 a \$1.50.  
 Do. rollers, each, 75c. a \$1.  
 Dashes, buggy, \$1.75.  
 Door-handles, stiff, 50c. a 63c.; coach drop, per pair, \$2 a \$3.50.  
 Drugget, felt, \$1.62.  
 Enameled cloth, 5 qrs., 75c.; 50 in., \$1.55.  
 Enameled linen duck, 4 qrs., 55c.; 5 qrs., 75c.; 52 in., 90c. Colored, 15c. higher per yard.  
 Felloe plates, wrought, per lb, all sizes, 18c.  
 Fifth-wheels wrought, \$1.38 a \$2.  
 Fringes, festoon, per piece, \$1.75; narrow, per yard, 18c.  
 ☞ For a buggy top two pieces are required, and sometimes three.  
 Do. silk bullion, per yard, 35c. a 75c.  
 Do. worsted bullion, 4 in. deep, 35c.  
 Do. worsted carpet, per yard, 6c. a 10c.  
 Frogs, 38c. per pair, or \$1.63 per dozen.  
 Glue, per lb, 25c.  
 Hair, picked, per lb, 50c.  
 Hub-borers (Dole's) for light work, \$15; heavy, \$18 a \$20.  
 Hubs, light, morticed, \$1; unmorticed, 75c—coach, morticed, \$1.50  
 Japan, per gallon, \$4.50.  
 Knobs, English, \$1.75 a \$2.  
 Laces, broad, silk, per yard, 85c.; narrow, 12c. to 15c.  
 Do. broad, worsted, per yard, 37 $\frac{1}{2}$ c.  
 Lamps, coach, \$14 a 18.  
 Lazy-backs, \$9 per doz.  
 Leather, collar, dash, 27c.; split do., 17c.; enameled top, 27c.; harness, per lb, 45c.; flap, per foot, 15c. a 20c.  
 Linen, heavy, a new article for roofs of coaches, 55c. a 70c. per yard.  
 Moquet,  $1\frac{1}{4}$  yards wide, per yard, \$5.  
 Moss, per bale, 10c.  
 Mouldings, plated, per foot, 12c. a 15c.; lead, door, per piece, 30c.  
 Nails, lining, silver, per paper, 6c.; ivory, per gross, 25c.  
 Name-plates.  
 ☞ See advertisement under this head on 3d page of cover.  
 Oils, boiled, per gallon, \$1.50.  
 Paints. We quote white lead, extra, \$3; Eng. pat. black, 25c.  
 Pekin cloth, per yard, \$2.  
 ☞ A very good article for inside coach linings.  
 Plushes, per yard, \$2 a \$3.  
 Pole-crabs, silver, \$5 a \$6; tips, \$1.12.  
 Rubbing stone, per lb, 12c.

Sand paper, per ream, \$3.75.

Screws, gimlet.

☞ Add to manufacturer's printed lists 20 per ct.

Do. ivory headed, per dozen, 38c. per gross, \$4.  
 Scrims (for canvassing), 15c.  
 Seats, buggy, pieced rails, \$1.75; solid rails, \$2.50.  
 Shaft-jacks (M. S. & S.'s), light, \$2.60; heavy, \$2.87. a \$3.25.  
 Do. tips, extra plated, per pair, 31c.  
 Silk, curtain, per yard, \$1 a \$2.25.  
 Slat-irons, wrought, per pair, 55c.  
 Slides, ivory, white and black, per doz., \$6; bone, per doz., \$1.50;  
 No. 18, \$1.75 per doz.  
 Speaking tubes, each, \$4 50.  
 Spindles, seat, per 100, \$1 a \$1.25.  
 Spring-bars, carved, per pair, \$1.  
 Springs, best temp. Swedes, per lb, 24c.; black, 17c.; bright, 18c.; best tempered, 21c.  
 ☞ Two springs for a buggy weigh about 23 lbs. If both 4 plate, 34 to 40 lbs.  
 Spokes, buggy, per set, \$3.30, or about 5 $\frac{1}{2}$ c. each for all under  $1\frac{1}{2}$  in.  
 ☞ For extra hickory the charges are 7c. each.  
 Steel, Farist & Co.'s Homogeneous American, per lb, 16c.  
 Do. English Homogeneous, do. 20c.  
 Do. Compound tire, from \$6.50 to \$7.75, according to thickness.  
 Stump-joints, per dozen, \$1.25 a \$1.50.  
 Tacks, 5c. and upwards per paper.  
 Tassels, holder, per pair, 63c. a \$1; inside, per dozen, \$3; acorn trigger, per dozen, \$1.25 a \$1.50.  
 Terry, per yard, \$7.  
 Top-props, Thos. pat., per set, 35c.; plain, com., 35c.  
 ☞ The patent props, with silver-plated nuts, per set, 87 $\frac{1}{2}$ c.  
 Tufts, ball, per gross, 50c.; common worsted, 12c. a 25c.  
 Thread, Marshall & Co.'s Machine, No. 432, \$2.40 per half lb; No. 532, \$2.75 do.; No. 632, \$3.50 do.  
 Turpentine, per gallon, \$3.75.  
 Twine, tufting, per ball, 35c.  
 Varnishes (Amer.), crown coach-body, \$5 a \$5.50; hard drying, \$6.50; nonpareil, \$7.  
 Do. English, \$6.25 in gold, or equivalent in currency on the day of purchase.  
 Do. American imitation of English, \$7.  
 Webbing, per piece, 44c.  
 Whiffle-trees, coach, turned, each, 25c.; per dozen, \$2.50.  
 Whiffle-tree spring hooks, \$3 per doz.  
 Whip-sockets, rubber, per dozen, \$7 a \$9; pat. leather, stitched, \$3.  
 Window lifter plates, per dozen, \$1.50.  
 Yokes, pole, each, 75c. to \$1.25.  
 Yoke-tips, 50c. a 75c.

We intend to carefully correct this list monthly, so as to enable those who commission us to make their purchases to ascertain by computation about the amount they require to remit us. This should be done, if a large sum, by draft to our order in New York, or if small, in a registered letter to our address. None but cash orders filled, and where C. O. D. bills are forwarded with the goods by express, charges for collection must be added, which amount in ordinary cases to from 25c. to \$1, according to distances. All this may be saved by sending us the money with the order. Please read notice of "General Business Agency," on 3d page of the cover, in connection with the above.

## TO READERS AND CORRESPONDENTS.

BACK VOLUMES of this work will be sold, in numbers, for \$3; when bound, for \$3.50, to which, if sent by mail, 48 cents must be added to prepay postage; if two or more volumes are called for at one time, they can be had for \$3 each, or will be sent by express, at the purchasers' expense, at the same price. The subscription to the Fifth Volume, now in course of publication, will be (in consequence of the advance in paper and printing) four dollars, IN ADVANCE, for the twelve numbers; and these will be issued, in 1863 for Jan., March, May, July, Sept., Nov., Dec., and afterwards monthly until the close of the volume in May, 1864.

AGENCY.—Our friend Mr. Henry Harper, who is traveling in the West, is authorized to take subscriptions for us, and receipt for moneys paid; and any contract he enters into concerning this Magazine will be honorably carried out by the Publisher. In Canada West, Mr. Robert McKinley, at St. Catharines (dealer in carriage-hardware), will act as our local agent.



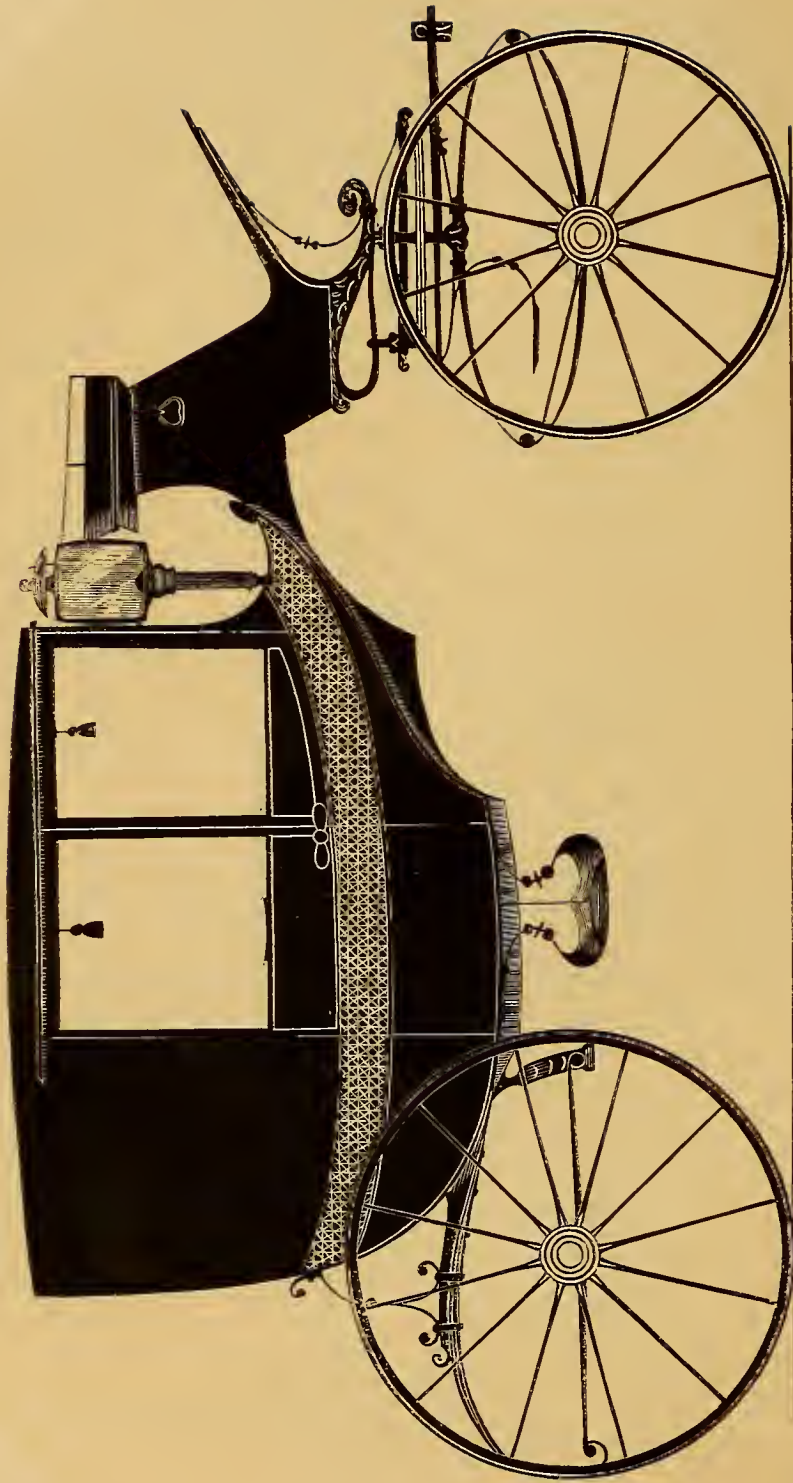

DRAG-FRONT COACH.— $\frac{1}{2}$  IN. SCALE.  
*Designed expressly for the New York Coach-maker's Magazine.  
Explained on page 136.*

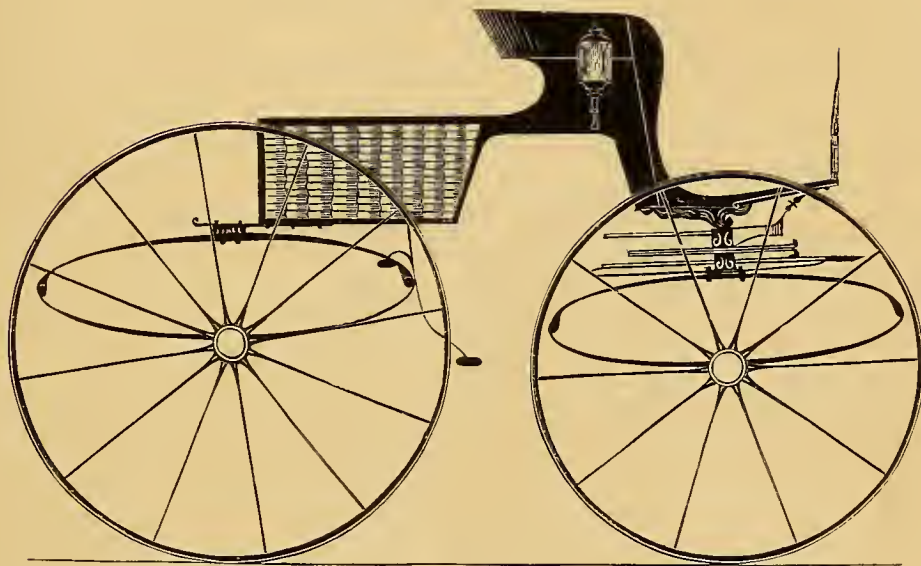

TILBURY PHAETON.— $\frac{1}{2}$  IN. SCALE.  
*Designed expressly for the New York Coach-maker's Magazine.*  
*Explained on page 136.*









CANED GO-CART.— $\frac{1}{2}$  IN. SCALE.

*Designed expressly for the New York Coach-maker's Magazine.*

*Explained on page 137.*

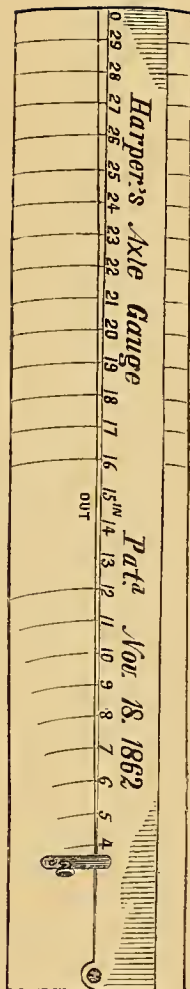

Fig. 1.

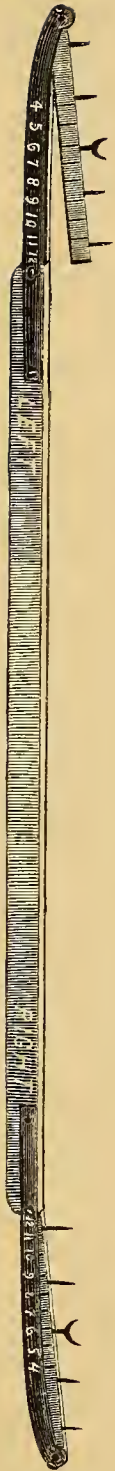

Fig. 2.

HARPER'S AXLE SCALE AND GAUGE.

*Engraved expressly for the New York Coach-maker's Magazine.*

*Explained on page 137.*





DEVOTED TO THE LITERARY, SOCIAL, AND MECHANICAL INTERESTS OF THE CRAFT.

Vol. V.

NEW YORK, FEBRUARY, 1864.

No. 9.

## Mechanical Literature.

### EFFECTS OF WHEEL-CARRIAGES ON ROADS AND HORSES.

#### CHAPTER IV.

1. A new principle suggested as important in the construction of Carriages, viz: THE DIVISION OF WEIGHT OR POWER, by the use of a greater number of wheels for the same load; thus causing less labor to the Horses and less injury to the Roads. 2. Carriages should pass the road with the least possible weight on any one wheel. Less labor required to draw several wheels in succession, over an obstruction, than to draw one wheel, carrying the same amount of weight, over the same object. 3, 4, 5. Illustration of this Theory. 6. Breadth of wheels no security against the destructive effects of pressure. Broad wheels on paving stones. 7. The principle of light pressure should be carried as far as may be consistent with public convenience. 8. Light wagons of one horse suggested. 9. Six-wheel and eight-wheel carriages recommended; were in use some years ago. Were remarkably easy to travelers. 10. Had one defect in construction. 11. Carried enormous loads with four horses.

1. THERE is a principle, which I do not remember to have seen noticed, and which I consider of great importance, as applicable to this subject. It may be called THE DIVISION OF WEIGHT, or, more philosophically perhaps, THE DIVISION OF POWER: that is to say, the division of the power, which any carriage may possess, to crush or destroy the materials of the roads; and the division of the power, which any carriage may possess, to resist the power of the horses drawing such carriage.

A man can break an ordinary stick, an inch in diameter, across his knee; but if he tie ten of these sticks together, he could not break them if he tried ten times, nor if he tried a thousand times; although, by these thousand efforts, he might have broken a thousand such sticks separately. A stone might be of such a size and texture that a strong man with a large hammer might break it into pieces at one blow; while a boy with a small hammer, striking it with one-tenth part of the force, might strike it a thousand times, applying in the whole one hundred times the power upon it that the man would have done, without producing the same effect.

So it is with the pressure of wheels on the materials of roads. Suppose a stone, the size of a man's fist, to lie detached on a firm part of the road, and a wagon-wheel, pressing with the weight of two tons, were to pass over it, the consequence would be that it would crush it to powder. But suppose these two tons to be distributed into forty wheelbarrows, of one hundred-weight each, and they were to pass over it in succession, the only effect

likely to be produced would be a trifling rounding of its corners; nor would probably five hundred such wheelbarrows, or twenty-five tons, crush the stone so completely as the single wagon-wheel; nor do I think that five hundred gig or one-horse chaise wheels, of four hundred-weight each, in all one hundred tons, would so completely destroy the cohesion of the stone, as the single crush of the heavy wheel.

2. Conceiving, therefore, that the destructive effect of pressure on the roads increases, from the lowest weights to the highest, in a very rapidly increasing ratio, I think that all reasonable ingenuity should be exercised, so to construct our carriages as for each wheel to press the road with the least possible weight that the public convenience will allow. Besides, it is considered a mathematical axiom, that action and reaction are equal. If I fire a gun, the breach is pressed against my shoulder with exactly the same force as that with which the shot is discharged. So, in crushing a stone with a heavy wagon-wheel, so much power of the horses is expended and misapplied upon it as is necessary to overcome the resistance occasioned by its cohesion or firmness with which its parts were held together; whereas, if these two tons were divided upon eight wheels, of five hundred-weight each, the horses would draw them *over* the stone, one after another, with perhaps a tenth-part of the exertion or expenditure of strength that was necessary to break the stone.

3. Were it necessary, I could adduce practical proof of the soundness of this theory. Some years ago, the Brewers in Bristol had, most of them, two-wheel drays, carrying four barrels each, and drawn by one horse, for sending out small quantities; when a friend of mine, at my suggestion, had a four-wheeled carriage made, the hind-wheels of which were three feet high, and the fore-wheels about two feet four inches high; the carriage complete weighing about eight hundred-weight; it being about eight feet long in the bed, to carry three barrels on each side; which six barrels, at four hundred-weight each, weighed twenty-four hundred weight: total, thirty-two hundred-weight. This was found easy work for one horse, although firmly protested against by the *man of experience* whom my friend employed, as a carriage that never would answer his purpose. It was quickly imitated by other brewers; and these carriages are found so completely useful and convenient,

that now (1820) they are more frequently seen in the streets of Bristol than any other sort. I have also proved, by abundant practice, that three horses can draw a ton more gross-weight, on a well-constructed four-wheel carriage, than they can upon one with two wheels. I am not aware that this is to be accounted for on any other principle than that which I have just brought forward. And as this increased facility, on the part of the horses, is owing to the lighter pressure of the wheels on the ground, so, in proportion as the labor of the horses is lessened, is the action of the wheels on the roads; or, in other words, in that proportion is the wear and tear of the roads diminished.

4. Lest the principle I am desirous of establishing should not be clearly understood, I will endeavor further to explain it, with all possible perspicuity. I will suppose the two-wheel beer-carriage, above mentioned, to weigh ten hundred-weight, and the four barrels of beer to weigh sixteen hundred-weight: total, twenty-six hundred-weight. Each wheel, then, pressed the ground with a weight of thirteen hundred-weight, which was the weight that the horse would have to draw out of every hollow, and over every obstruction, at *one* effort; whereas, in the case of the small four-wheel carriage, the horse would have to overcome the resistance of only eight hundred-weight at one time; and it is proved by abundant practice, for many years past, that he can draw two of these weights in succession over each obstruction, one behind the other, that is to say, one on the fore-wheel and one on the hind-wheel, with less *labor* than he can draw thirteen hundred-weight over each obstruction at once.

5. The London Porter Brewers would find exactly a similar result from a like change. One of their two-wheel drays weighs about seventeen hundred-weight; on this they load three butts of porter, at twelve hundred-weight each, say thirty-six hundred-weight: total, fifty-three hundred-weight. The horses have half this load, or twenty-six and a half hundred-weight, to resist at every obstruction that either of the wheels may encounter. A four-wheel carriage *need not weigh more than seventeen hundred-weight*, to carry *four butts*: total, sixty-five hundred-weight; of course the horses would never have to encounter more than sixteen and a quarter hundred-weight at any one obstruction, at one time. The Brewers would find their horses draw *four butts more easily*, on a well-constructed four-wheel carriage, *than they now draw three*.

In the construction of a four-wheel carriage for four butts, it should be remembered that, whereas now each wheel has to carry *half* the massy bed and one butt and a half,—then, in the case of a four-wheel carriage, as the bed would have *two bearings*, the side-pieces or blades need not be half, nor a quarter, so heavy as the present; and as each wheel would carry only its *fourth* of a light bed, and only *one butt*, it should, as well as the axles, be proportionally light. For such a carriage I would suggest four feet as a suitable height for the hind-wheels, and three feet for the fore-wheels. And I am firmly of the opinion that neither the paving of the streets nor the gravel of the roads would suffer a tenth so much from four wheels of sixteen and a quarter hundred-weight each, whether wide or narrow, as from two wheels of twenty-six hundred-weight each. It is the intensity of pressure that does the mischief.

6. It may be argued that twenty hundred-weight, on a

six-inch wheel, presses with the same weight, in any one point, as ten hundred-weight on a three-inch wheel. This would be the fact if the roads were perfectly flat and smooth, and if the wheels were perfectly cylindrical. It is possible to make roads perfectly flat and smooth; therefore, even a cylindrical wheel would rarely press *alike* with the whole breadth of its rim, on the roads; but it would press most heavily with one edge on the other, or with some intermediate point. Hence it follows that, to allow weights to increase with an increased width of wheels, is to admit a principle which, however, sound in theory, is not sound in practice. But as applied to the pressure of wheels on roads, as well as to the resistance they would cause to the horses, the principle is not sound in theory; because, six-inch wheels must pass over twice as much loose and detached matter as three-inch wheels; and, whenever a six-inch wheel meets a single stone, the effect on that stone would be precisely the same as though the wheel was only three inches wide. In this point of view, the evil of admitting this principle would be two-fold, as it concerns both the roads and the horses. First, the evil of increased weight, which I have alluded to in the first section of this chapter; and, secondly, the increased breadth of the wheel, whereby twice the quantity of loose matter would come within its destructive influence. But this theory is unsound in another point of view, as applied to roads. We are not to consider roads as solid rocks, but as quantities of matter, very modestly cemented together, and in some cases not cemented at all; therefore, a GREAT WEIGHT, IN ONE ROLLING MASS, has a tendency to disturb the entire bed of the road, whether it be on a six-inch wheel, or on one of sixteen inches. Under all these considerations, I am satisfied that the only grand desideratum, on behalf both of the road and the horses, is LIGHT PRESSURE. And therefore, any dependence on breadth of wheels, as a security against the destructive effect of pressure, is, in my opinion, fallacious.

I wish here to be understood as applying these remarks under a supposition that wheels were made upon the best philosophical construction; that is to say, perfectly cylindrical; and that they stood perfectly upright or vertical. The present system of broad wheels I consider a system of mere mockery. I suppose that not one nine-inch wheel in one hundred bears on the ground more than three inches; that is to say, if such a wagon were to be placed on a paving of flag-stones, that the parts of each wheel in contact with the stones would not exceed three inches. It is very true that, when we follow such a wagon, on a turnpike road, we often see a track nine inches wide. Now, these wheels are round in every direction; and generally speaking, the roads are round also: it is therefore *impossible* for these wheels to leave a nine-inch track, by *any other* operation than that of impression, or *squeezing in*. Whenever, therefore, such a track is anything more than an impression in the dirt, it is an impression into the road itself, by the last-mentioned operation, viz: a disturbance or disarrangement of the body of the road.

I have called it a system of mockery; such it really is: for there seems the most perfect understanding between the mockers and the mocked. I have even known the trustees of turnpike-roads make gratuitous concessions of *half the tolls* in favor of broad-wheel wagons; contrary, as it appears to me, to their own special Act of Parliament.

The foregoing reasoning is also applicable to the

streets of London. It would be ridiculous to insist that any advantage can possibly result from the use of broad wheels on these paving stones, nearly every one of which is round on its upper surface. A six-inch wheel of a brewer's dray, in contact with one of these stones, is merely a collision of two convex bodies, each extremely hard, one against another. I might almost say spherical bodies; for that is the real figure of what the law supposes to be a conical wheel; and it is nearly the figure of these stones; consequently the surfaces in contact, at any one time, are extremely small; little more than the surfaces in contact of two eggs in a basket.

7. If it be admitted as a principle of importance, for the preservation of our public roads, that the thousands of tons of commodities of all sorts which are constantly rolling over them should be divided out on as many wheels as possible, it remains to be considered how far the principle can be carried, consistently with public convenience, and by what means it can be affected.

8. There are two means by which this can be affected: first, by light wagons for one horse; and secondly, by the use of carriages of six or eight wheels.

One-horse wagons fully embrace the principle; and the labor of the horses would be much more efficiently applied than at present. If one-horse wagons were constructed to weigh eight hundred-weight each, and these were charged with a load of sixteen hundred-weight each, a good ordinary cart-horse would travel England over with such a load; drawing just as much *nett-weight* as the ten horses in a heavy wagon take each in *gross weight*; and the roads would never have a pressure, on one point, exceeding six hundred-weight. The only objection to such carriages, that I see, is, that each must be attended by a man. But were they adopted, roads would last—I will not say ten times as long—I think they would last a hundred times as long as they now do. Carriages so constructed ought, therefore, to pass at the lowest possible rate of toll.

9. The next mode is by the use of carriages with six or eight wheels. About twenty years ago [1800] there were several stage-coaches constructed in this manner.\* Two eight-wheel coaches plied some years between Bath and Bristol, and they were so constructed that each wheel supported its share of the load, carrying its proportion, and no more, over every obstruction; the consequence was, that when a wheel passed over a stone two inches high, the middle part of the carriage rising only an eighth part of two inches, or one quarter of an inch, they were perhaps the easiest coaches, to passengers, that ever were sat in.

10. They had, however, one defect in their construction, which was, that the two hinder-axles being fixed, whenever the coach varied from a straight line on the road, the hindermost pair of wheels, must have dragged sideways. How the six-wheel coaches were circumstanced in this respect, I had no opportunity of observing.

In constructing carriages with any number of axles, the object required is for the machinery to be so contrived, that whenever the carriage is going in a circle, if a line were drawn through each of the axles, all the lines should

meet at one point; which point is the centre of the circle in which the carriage is traveling. In this case, every axle would move fairly, without any drag, sideways.

11. There is now living in Bristol a man who constantly drove one of these eight-wheel coaches between that city and Bath. He informs me they carried fourteen inside and sixteen outside passengers, besides luggage. With this enormous load he used to go between the two cities, twelve miles off the road, at that time much more hilly and in worse condition than at present, with four indifferent horses, in two hours. I understand the reason why these two coaches were discontinued was, that, as they carried at a low price, they were often filled with a crowd of mean people; which disgusted the more respectable travelers, to whom alone the proprietors could look for permanent custom: the coaches of course dropped.\* This, however, does not affect their principle as machines; on the contrary, the report of them tends greatly to confirm the theory I have attempted to establish.

### POMPEIAN ROADS AND CARRIAGES.

BY THE EDITOR.

OUR history would be imperfect did we omit to notice, as an appendix to our recent chapters on "Ancient Roman Carriages," the roads of Pompeii, and some of the designs of vehicles, found in its frescoed walls, recently exhumed. These designs, it is true, are the productions of the painter's brush, but then their variety goes to show a strong evidence in favor of their once real existence, as objects of mechanical skill. Pompeii was at one period an independent state; but, through political indiscretions and intermeddling with the quarrels of other nations, she drew down upon her the power of the Roman Government. Once subjected, the language and customs of the Romans were soon adopted.

Pompeii was destroyed in the year 79, by an eruption of Vesuvius, entirely burning it with a shower of stones, cinders, and ashes. Beneath this debris, for ages has been preserved objects of the deepest interest to the modern antiquarian.

Approaching Pompeii from Naples, both sides of the road, for nearly three miles, before entering the city, were occupied by huts and public monuments, intermixed with shops. In front of the latter, arcades were constructed, affording shelter from the rays of the sun or inclemency of the weather. The *agger*, or carriage way exhibiting the tracks or ruts (sometimes four inches deep, the wheels seem to have been about three inches wide, and from three feet to three feet six inches apart,) worn by chariots, is narrow, seldom exceeding fourteen feet in width, with footways, or *margines*, on each side, varying from four to six feet, elevated above the road about a foot, and separated therefrom by a curb and guard stones, raised about sixteen inches, and placed at intervals of from ten to twelve feet asunder. The whole of the road was formed of lava, in irregular-shaped blocks from ten to fourteen inches thick, originally well joined and put together. Indeed, its state of preservation sufficiently attests the perfection of

\* It does not appear that these coaches were introduced on the ground of any philosophical principle, but merely as a whim of the day. Even Richard Lovell Edgeworth, alluding to the existence of six-wheel and eight-wheel coaches, says, "eight wheels have been applied to carriages, but it is difficult to comprehend upon what principle."—Ed.

\* Cheap lines always attract the poorer class of travelers, and these are generally, even where water is abundant, very dirty. If any one doubts this, let him patronize the "three cent lines" in New York City, and experiment for himself. Can any one explain why poverty and dirt are so frequently found in company? Ed.

the principle upon which it is constructed. On these roads, though excellent, travel was comparatively slow. Augustus took two days to go from Rome to Præneste, twenty-five miles; and Horace, in going to Brudusium, took the same time to travel forty-three miles, but he thinks an expeditious traveler might do it in one day.

Some specimens, among other curiosities, of designs for carriages, have been preserved by Sir William Gell, in his *Pompeiana*. These we purpose to transfer to our columns.

The first example more nearly comes up to our modern ideas of what constitutes a perfect vehicle, than any other antiquity has bequeathed us. It is taken from a painting

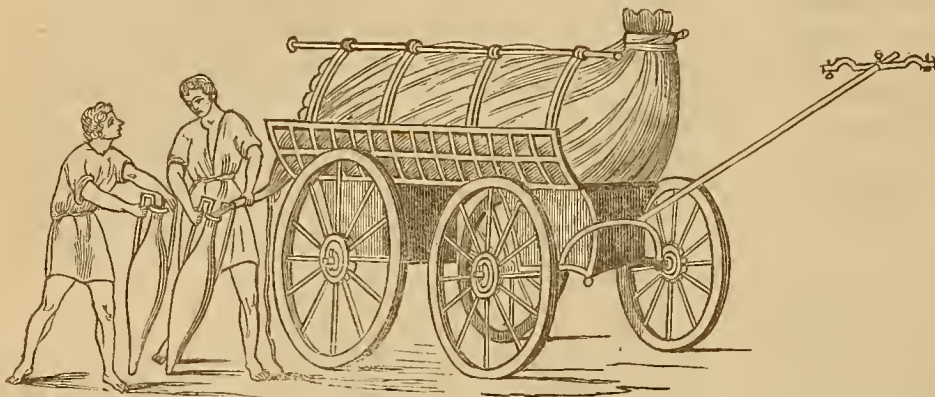

Fig. 1.

found in a little ante-room, or passage, of the Lupanare. It is rather slovenly done in the original copy, but it shows very plainly that the ancient Pompeians not only used wagons, but that they were, in design at least, equal to many of more modern construction. A critical inspection of the drawing will show that a great deal of genuine ingenuity and artistic taste are displayed in the arrangement of the different parts, for their adaptation to practical business use. The wheels are very nearly of equal diameter, and very high—peculiarities fitting them for easy draught, and suggesting to the mind of an American coach-maker the conviction that some ancient mechanics were far in advance of many of their European cotemporaries. There is a recess in the under-side of the body to permit the wheels to pass under in turning, and the whole is represented to be well painted, with a blue-colored body and yellow wheels. The enormous skin, stretched from a well-arranged frame work in the body, and which it is presumed contains wine, is a singular piece of workmanship. Notice how well calculated the ribbed body is for showing off the merchant's wares. The dresses of the two attendants, filling the jars, are simple but very graceful. This, in all probability, represents the wagon and servants of a Pompeian wine-merchant, proprietor of the house, who appears to have sold wine in leaden jars, in the *thermopolion*, or front shops, shown in the painting. The fact of its being found in another chamber of the same building, in duplicate, strengthens the opinion, and leads us to conclude that it was the "show card" of some enterprising business man.

(To be concluded next month.)

#### SAND-PAPER.

THE manufacture of sand-paper is an occupation attended with serious evils. The pulverized sand and glass are placed in fine sieves, and, by gentle motion, the powder is equally distributed over paper prepared for its

reception. The distribution is done by the hand; and as it is light work, young boys, hardly relieved from leading-strings, are employed at it. The result is, that the distributor, from the moment his work commences, is exposed to the inhalation of the irritative dust. Dr. Richardson, in a recent lecture, stated that a boy was one day brought before him, fatally struck by a chest affection resembling acute pulmonary consumption. On inquiry, he found that the youth, then engaged at the sand-paper business, was in perfect health until the first day he entered on his work. On his return in the evening to his home, he brought with him cough and pain in the chest, which never left him. Quickly his health failed; and when the doctor saw him only three weeks after the commencement of the labor, his chances of life were over; and he died within a month. Making further inquiry into this business, it was found that the poor youth was the representative of a great class of youths similarly disabled. There were few who ever stood the work. It adds, says the doctor, to the shame of these occurrences, that, except in the matter of pecuniary saving in the purchase of young hands, all risk is unnecessary; that, by very simple machinery, the manufacturer might dispense with

the distribution by hand altogether; and that the particles of irritative powder need never be so distributed through the air as to be breathed either by the manufacturers or their assistants.—*Engineer*.

#### CRYING IN OLDEN TIMES.

IN the seventeenth century, advertising was chiefly monopolized by public cryers, appointed by the different towns, for which service they received a stipulated sum from their employers. The following extracts from *The East Anglian*, No. XXX., published at Lowestoft, England, showing how run-away apprentices and stolen property were advertised, will interest the reader:

1692, 9th October.—Cryed yr. one broune blacke horse Aboute 14 hands high, with A Starr on his foorehead and whight foot behinde, and A wall eye on the oft side, and the other eye in his head but he is allmost blinde of bothe, and two saddle spots on etch side of his back, taken or strayed oute of the pasture of Mr. John Brooke, minister of Great Yeldom, in Essex, &c.

1693, 2nd December.—Cryed at severall places in Clare, A hagg saw of John ssollowes, in Clare; it is about 4 foot long, Borrowed or stolen oute of his shop Aboute 3 or 4 months agoe.

1696, 2nd October.—Cryed in Clare markt, a ladd that rann away from Isaac Brownesmyth, in grigory parish, in Sudbury; he is aboute 17 or 18 years ould, with a fresh cullered light browne hatt and a fuschin frock, with an ould coate under it, with sad cullered briches and sad cullered stockens.

1701, 11th September.—Cryed in Clare one Thomas Sparrow, apprentice to one John Barnard, of Sudbury, who did run away from his master on the 23rd day of last August: he hath a muddy complexion & browne hair, with a scarr upon his forehead, with a sad cullered fuschin frock & a payer [pair] of callimankoe briches, & sad cullered stockens.

1704, 7th July.—Cryed in Clare markt one John



Woods, Apprentice to John Snell, in Clare, who Ran Away from his master; the boy About 15 years of age, with a lank Browne Thick head of hair, and A round Plumpe palle visage, he hath had the small pox, he had A light cullered Coate & wescoate and Britches of Siminment Culler, and Gray wollen stockens and a black hatt.

### CARRIAGE WHEELS.—THEIR MECHANICAL CONSTRUCTION AND USE CONSIDERED.

BY HENRY HARPER.

(Continued from page 115.)

**DISHED WHEELS.**—The different practices that prevail in making wheels, either dished or straight, indicate so little thinking by those who are carried away with the latter fashion, that it will make one who has studied and understands all the principles involved in the question, almost ashamed that he belongs to a craft where there are so many members who entirely disregard philosophical principles in the construction of wheel-carriages. The dish to a wheel may be said to be the very foundation in the construction of a carriage; and if that foundation is wrong, the whole superstructure, necessarily, must be wrong.

The superintendence of carriage-making business at the present day, in many cases, has fallen into hands that know more about financiering than mechanism, and the importance of the thing is regarded by them as a pecuniary affair, rather than in the light of an interesting and ennobling science of mechanism. The fashion is the thing that brings the money, and they are as ready to sacrifice scientific principles to fashion as the most accomplished belle that ever wore a bustle, or stood within hoops. This is all right in that class of men; they turn their knowledge to a profitable account, and it makes the business interesting, as long as it brings in the dollars; but, to the craft it is humiliating in the extreme, and what is the worst of all, the craft bring the degradation upon themselves by a neglect of one of the most important duties.

The financier pays his money at almost every turn for information in his calling. How many thousands of the carriage-making craft suppose that the science pertaining to their trade has been completely exhausted, and that they have got it all stowed away in their skulls, and nothing more is left for them than to hew, shave and plane. This class of men are every day rooting over the pearls that belong to their occupation, without knowing it. No wonder that such men have learned "the meanest trade on earth," and spend their days working unwillingly, perhaps growling at some more enterprising man, who is taking the business out of their hands!

Those who understand the cause and effect of the principle on which they are working—or are learning something new about causes and effects—and have not been so unfortunate as to learn enough to render stale all knowledge belonging to the craft, will have a more cheery time in developing principles. The work of making a wheel, and adjusting it in a proper position, we believe can be made more interesting than any other part of a carriage, by simply understanding the philosophy of its construction.

By dishing wheels to a proper extent, strength and durability are gained, convenience for constructing the other

parts of the carriage, easier draught, more graceful appearance to the whole carriage, and more convenience in the use of the vehicle after it is constructed; therefore, as we have said, it is the foundation on which the structure must be built. *A straight wheel is the reverse of all these essential qualities.*

We now propose, (viewing a wheel under all of the above heads,) *First*: Its strength and durability. Every person deserving the name of mechanic, will make all parts of the machinery serve as many useful purposes as he can; particularly so in carriages, where moving the machine calls for motive-power in proportion to the heft of the machine. The tire to a wheel is put on to the rim in order to place a hard substance between the softer wood and the ground, and prevent the ground from wearing out the wood: this is one use. Another is to strengthen the wheel. In both cases, it is desirable to have the object accomplished with as little heft of iron as can be used, because every pound of heft will cost from three to five dollars worth of motive-power to draw the vehicle around until the same is worn out. Does the man deserve the name of being a mechanic who will throw away one of the uses for which the tire is useful, and make up the deficiency in weight, which will cost from three to five dollars a pound, or leave the deficiency unsupplied, only applying the tire to one purpose? Certainly not. But this is a fair statement in the case of those who make their wheels straight.

It so happens that the strain on a wheel always comes on one particular point, crowding it one particular way; that is, on the bottom side of the wheel, crowding it inward. This can be understood by raising up the wheels on one side of the wagon; the higher we raise them, the less the bearing is on them, until we can get them to a point so much above the wheels on the other side of the wagon, that they will rise of themselves and pitch over. The same thing occurs in a wagon slewing around. The wheels on one side of the wagon will rise up from the ground and pitch over the wheels on the opposite side of the wagon. Most of us have had practical experience in this matter.

In such cases it is well known that none of the heft is relieved from the wagon, but changed from one wheel to the other, making the latter bear double its proportion. When in this state, the position of the wheel is uniformly the same; that is, the upper part of the wheel is canted over from the wagon, and the under part turned in under the wagon; therefore, the heft rests on the under side of the wheel, crowding it inwards, and never outwards; therefore, we have only to fortify the wheel for this emergency.

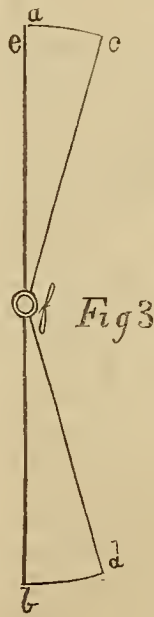

By dishing the wheel, or driving the spokes on the opposite sides of the wheel angling to each other, the object is most perfectly attained, by throwing the strain off from the spokes, and making it act as a draught lengthwise on the tire, which is perfectly able to sustain it three times over, without detracting in the least from its use in preventing the rim of the wheel from wearing out. Figure 3 will illustrate the idea. *a* and *b* are spokes driven into the hub, *f*, perpendicularly to each other, and would form what is called

a straight wheel. This shows an edgeway view of the wheel, and in this view the tire and rim of the wheel would form a straight line from *a* to *b*. *c* and *d* are spokes of the same length, that are driven angling to each other into the hub, *f*. The same view of this wheel would show the rim and tire to be on a straight line from *c* to *d*. Although these spokes are of the same length, the diameter of the dishing wheel is less than that of the straight wheel, and the tire will not allow the diameter to be enlarged. If we put a strain upon the bottom of the dishing wheel at *d*, and crowd it towards *b*, it will enlarge the diameter of the wheel. If the diameter is enlarged, the circumference is enlarged three times and a fraction over, as much. The circumference is the length of the tire, which cannot be drawn by such a strain one particle. The only way the dished wheel can be moved from *a* to *b*, is to indent the end of the spoke into the hub at *f*, or, to bend the spoke into a circular form, so that it will allow the spoke to pass from *a* to *b* without enlarging the diameter of the wheel. This latter case sometimes occurs when the spoke is not of a proper proportion in size for the strain that is necessarily put on it, as we see in the plaything-wagons. But if the proportion is proper, this cannot occur.

It has been supposed by the advocates of the straight wheel, that the spoke being wider at the shoulder of the tenon that goes into the hub, that that makes a sufficient brace. It operates something like the dish of the wheel, but is not sufficient. Although the tire will not be lengthened by any strain that may be put upon it, yet, the heat which is given to it by being used in hot sand, expands the tire, and contracts the wood part of the wheel, so that what little amount of brace is got in this way is entirely lost on certain occasions. Again, it is supposed by some that the placing the spokes dodging, that this fortifies the wheel so that it will neither turn over backwards nor forwards, when a strain is put upon it. As we have said, there is no strain that can be put on a wheel which crowds the bottom of it out from the wagon; therefore, the precaution of guarding against such an occurrence is useless, and it is worse than useless, when we consider that the guard is taken from the place where it is of use, and placed where it is useless.

In the case of dodging spokes, where one is set a little angling and the other one straight, the one that stands on the angle necessarily has to be a little longer than the straight one, to fill out the diameter of the wheel, as will be seen in the diagram, where the angling spokes, *c* and *d*, do not make the same diameter of *a* and *b*, although they are of the same length. The effect that it has on the wheel is to lose the strength that is gained by the dish of the wheel to one half of the spokes. Suppose Fig. 3 is the angle of dodging spokes in a wheel, one half of them stand in the position of *a* and *b*, the other in the position of *c* and *d*. If the wheel should fall into a rut while the spoke *b* was down, and should bend it in towards the wagon, it would diminish the diameter of the wood part of the wheel, the same as it does to move it towards *d*; consequently, there is no strain thrown on to the tire by the spokes crowding the rim of the wheel against the tire. Those who will argue that there is sometimes a strain on the wheel outwards from the wagon, will find their argument subjects them to the same difficulty; for, if we bend *b* spoke towards *d*, or in an opposite direction, the effect is just exactly the same. In either case it lessens the diameter of the wheel, and we lose the support that is to be gained

by the spoke crowding the rim against the tire. This support is the greatest strength the wheel has.

Very little reliance can be placed upon the strength of the tenons where they enter the hub, without adding to it the support of the tire. In the case of dodging spokes, the greater part of the strength is lost; yet there is some advantage derived from the resistance the tire would make to being bent sideways. Suppose that every alternate spoke was protected by throwing the strain on the tire, then the other alternate ones would derive some of that protection, because, in order to make them give way to a sideway pressure, the tire would have to bend sideways, between the two which were protected; then that support would depend on the weight of the tire. We may have no fears about a tire of sufficient thickness to protect the rim of the wheel from wearing out, being pulled apart by the strain thrown upon it; but in order to prevent it from bending from a sideway pressure, an additional heft would be required, which is a damage to the wagon ultimately of four or five dollars per pound. Such things are necessarily to be considered in the propositions necessary for a wagon.

We then can come to no other conclusion than the one that a wheel should be dished, and that every spoke should stand at the same angle, notwithstanding that some think the hub is the stronger by making the mortices dodging. We do not regard the advantage gained in that respect, sufficient to balance what is lost in other respects.

(To be continued.)

## Home Circle.

### THEN AND NOW.—A LIFE SCENE.

BY ANNIE M. BEACH.

THEY were children then, and the sunny hours  
Were spent in the meadows among the flowers,  
Or along the side of the silver stream  
That sung its song in the sunshine's gleam.  
And when Winter had frozen the land and tide,  
They walked to the school-house side by side.  
Her hair was of black, and his as brown  
As the nuts that drop in the autumn, down.

Of all the lads that were bold and fair,  
She looked on him as the bravest there.  
And when he thought of the future far,  
She was forever the guiding star;—  
The maiden there, with the hair of black  
From her broad white forehead braided back;  
And, glancing up from his book, well worn,  
He smiled, as her kind eyes met his own.

Thus the years of their childhood passed away  
Like the morning time of a pleasant day,  
Till youth came on, and the rose-robed hours,  
Scattering their pathway with sweetest flowers.  
And so, one eve in the pleasant June,  
As they waked in the light of the silver moon,  
He breathed those words in her listening ear,  
Which they say but once in a life, we hear.

He stands in a costly hall to-night,  
The lamps are lit, and the wine flows bright.  
'Tis a gala scene; and they wonder why  
There speaks no joy from his hazel eye.  
There's a fairy figure in satin and lace,  
That leans on his arm with an easy grace;  
Her eyes are of blue, and her face is fair,  
And pearls look out from her golden hair.

But the young bride starts,—for the hand is cold  
That slips on her finger the ring of gold,  
And the voice is husky that murmurs low  
The solemn words of the marriage vow:—  
While thoughts go wandering backward,—back  
From the golden curls to the braids of black.  
And all the gold he has gained with his bride,  
He would give for an hour by his darling's side.

And she at a vine-clad casement low,  
Sits looking out in the twilight's glow,  
And thinks of a time in the pleasant June,  
When two walked out 'neath the silver moon.  
Her eyes drop down to a handsome face  
That is looking up from a golden case;  
She has answered the letter, and why, oh why,  
Does her Love delay in his kind reply?

"It will soon be coming!" Aye, lady, so,—  
It will soon be coming, and thou wilt know  
How much of anguish the heart can bear,  
And yet beat on in its still despair.  
Thou wilt learn to look with a cold distrust  
On all the friendship of human dust.  
The angels comfort thee, lady fair,  
And the angels pity thee, man of care.

CAMBRIA, N. Y.

## LOTTIE HILL.

BY LIA DELINN.

(Concluded from page 103.)

THAT despatched, I sat down and looked the matter in the face. The only light that had ever gladdened my dreary life had gone out forever. A little while I gave myself up to unavailing sorrow, and but a little while. My next feeling was one of indignation toward Adam Arnott, and then vowing that he should yet be proud to claim my acquaintance. I put him away from my thoughts. A year before this I had obtained a catalogue of the Temple Hill Seminary, and had been at odd times studying hard, that I might be able to enter the third year of the course, and so complete it in two years. Next week the fall session would commence. I was ready had it been the next day, for I made no change in my wardrobe, as you, Lucy, well remember. I could not do that until I knew exactly how much it would cost to board myself at the cheapest rate, for I must save enough to pay for lessons in music, drawing, and painting. This brings my history up to my life at school. Since then, you've known my trials and triumphs.

Lottie's triumphs at school were brilliant enough to reward her for many trials. She seemed to excel in every thing, and had the first place in all her classes. The influence of our principal secured a fine situation for her soon after she graduated, where she received a liberal salary as teacher. Having no longer a special motive for saving money, she spent it freely. She studied the art of dress, and of pleasing generally. Energetic as ever, she devoted a part of her time out of school to society, and a part to hard study. She took private lessons in French, German, and Dancing. In this way she had been teaching and studying four years, corresponding with me occasionally, when she wrote announcing her approaching marriage. The gentleman, she said, was a distinguished Judge in the city where she had been teaching; a widower unincumbered with children. Now, Lucy, don't turn to your Herbarium and rattle those dead leaves at me. Let

them remain and still speak to you of *Lottie Hill*. When I take the new name, she continued, I shall enter upon a new life, and will then, perhaps, give you some other token, which shall illustrate the new record as forcibly as those do the old. Don't imagine there is any romance connected with this affair. It's quite a business transaction. The Judge has a pleasing address, and, what is more to me, a high position. On forming his acquaintance, I went to work deliberately with a view to making a conquest. You know it is my rule to succeed in whatever I undertake, and you know the result. But, you are asking, dear simple soul that you are, Do you *love* him? I've the highest regard for him, and, if he treats me well, I shall learn fast enough to love him after a while. You know I am an apt scholar. You'd like to know if I have forgotten my quondam friend, Adam Arnott. By no means, as I hope to prove some day.

Lottie had been married some time before I heard from her again, and then she wrote, urging me to visit her at a given time. She had a special reason, she said, for making the request, which she would explain when she saw me. I found her so completely changed that it was difficult to recognize in her the Lottie Hill, whose uncouth appearance had provoked the ridicule of the whole school. Her features were the same certainly; the big brown eyes still monopolising an unfair portion of the face, but they had lost their faded look, and shone and sparkled as if they had always looked out on brightness. Taking her face as a whole, though far from pretty, it was yet such as none would fail to mark with interest. The little figure that we called dwarfish, in speaking of the awkward school girl, had not assumed more stately proportions, but no one, watching the graceful movements of the cultivated elegant women of society, would think of it otherwise than as *petite*. The greetings were scarcely over when Lottie began, "You are curious to know why I claimed your promised visit at this particular time. I'm anticipating some rare sport, and want some one to enjoy it with me as only you can, for you are the only person who knows all the incidents of my past life. Some time ago my husband became acquainted with, and very much interested in, a lawyer by the name of Ames, a stranger in the city. He was undecided about locating here in the practice of his profession; but a little encouragement from the Judge, who, on account of his position must, you know, have great influence, induced him to remain. He has been a frequent visitor at our house, is a great favorite with the Judge, an interesting young man, &c., &c. But the point I am coming to is this: he sent for a friend in the East to join him in business, becoming the senior partner; and the style of the firm is Arnott & Ames. A good word from Ames was enough to secure the Judge's favor for the senior partner, and now they come and go at pleasure after the manner of cousins. Mr. Arnott makes himself more agreeably than you would think it possible for so homely a man to do. Enter into conversation with him, and you almost forget that he is so homely. He has the most perfect self-possession of any person you ever saw, unless, indeed, I can match it, and that has been one of my great studies. I have a plan by which I intend to disturb his equanimity enough to make him express surprise in *looks*; it's doubtful whether he finds words for it. I'll not explain that to you now, for you can, ignorantly, further my plans far better than if you understood them. It's too bad, Lucy, for your pretty theory about First Love; and

yet you'll be glad to know that there is not the least emotion of tenderness for him lingering in my heart. I don't care enough to harbor even a feeling of resentment towards him. In that respect, my husband is his equal; and in every thing that goes to make up a high-toned, manly character, such as a woman of heart as well as intellect could do homage to, he is infinitely his superior. Do you think I didn't see that twinkle of your eye, and don't I understand that you have regarded me as wanting in delicacy and dignity, and still worse, wanting a heart, which, above all things, makes a woman *womanly*, ever since I made that unlucky confession about going to work deliberately and maliciously to win the Judge as the surest way to win the triumph I had determined upon? Well, Lucy, I confess with shame, though *not* with sorrow, I did 'stoop to conquer.' I know that I was winning his love as well as his hand, and determined to be a dutiful and affectionate wife. Duty! *I hate* the name. Love! Idolatry! are weak words to express the feelings with which I regard my husband. You believe in First Love, do you? I loved Adam Arnott with all the strength of my *un-developed* nature. I love my husband with all the power of a nature whose every faculty has been developed to the utmost. But enough of sentiment, it is not my *role*."

"Too bad you can't join us, Ad," said his friend Ames, as he led Lottie out to join the dancers. "Unfortunately that part of my education was neglected," Arnott replied, and his eye followed Lottie as she glided gracefully through the windings of the mazy dance. "Talented and accomplished, an ornament to society," I overheard shortly afterwards, as he concluded a remark which evidently had reference to her. "And though less brilliant, still more lovely in the retirement of her home," was the reply of a lady in whom I recognized one who could speak knowingly—an intimate family friend of the Judge. Lottie did not seek, neither did she avoid his society, but treated him with the same unembarrassed dignity and courtesy that she showed his partner. If there was a shade less of cordiality in her manner toward him, it was easily accounted for by the fact that Ames was a friend of longer standing. One evening, when my ear had just caught the familiar double tread of "the firm" upon the steps, Lottie quietly placed beside me a large port-folio of fine engravings and paintings, saying "I believe you've a passion for the Fine Arts?" There was a significance in her tone that I didn't understand, but it was plain she had a reason for bringing out the port-folio at that particular moment, so I was all absorbed in examining its contents when the gentlemen entered. Mr. Arnott and the Judge were soon deeply interested in the discussion of a knotty point of law. Lottie seemed to be carefully weighing the arguments on both sides, while Mr. Ames, a connoisseur, aided me in discovering the beauties and defects of the unusually fine collection. I was beginning to think myself at fault in suspecting Lottie of design with reference to the port-folio, when the gentleman took up a picture, at the same time naming its subject, "Just from the Country." "It's mate," I said, as taking from his hand a perfect likeness of Lottie, as I first knew her, I gave in its stead the unmistakable original of her description of her rustic lover. "Ad. Arnott, as I live!" he exclaimed in a tone of surprise that drew the individual in question, as well as the Judge, from the contemplation of the law to the study of the speaking pictures. They were fine paintings, purporting to have

been copied from daguerreotypes by Porter. "I don't understand it; I bought the whole collection at a private sale," said the Judge, with some embarrassment, thus unintentionally bearing his testimony to the fidelity of the likeness. "There's no denying its truth to nature, Ad, in everything but expression, but that has changed so materially as to make the copy seem almost a caricature; but, gentlemen," Ames continued, "I'm sorry to have interrupted your discussion; that picture brought back my early college days so vividly, that in true school-boy style, I thought aloud."

Adam's eyes started from their concealment as if to catch the new light that was dawning especially for them. It was the only sign he gave. The next moment they had settled back, and his face was as composed in its ugliness as ever. "Ames never forgets old friends," he said carelessly, addressing himself to me, but looking past me into Lottie's eyes. "Do you?" she asked, as carelessly handing him the memento of her own rustic life.

"No, not *forget*, but sometimes fail to *identify*, as in the present instance," said he, looking from the semblance down into the *living face*. His part was pretty well sustained while he talked with Lottie, but when the Judge took up the discussion where it had been broken off, he seemed incapable of comprehending the points, and, to the surprise of his opponent, agreed where he had before dissented. His partner noticed his abstraction, and proposed returning to their room on the plea of his own dullness. When they were taking leave, Lottie politely acknowledged obligations to them for occasionally enlivening our evenings by their presence. Ames replied something about the obligation being on the other side, but Arnott only said, "We'll *call it even*."

"He went like one that hath been stunned,  
And is of sense forlorn;  
A sadder and a wiser man  
He rose the morrow morn."

The Judge seemed prouder of Lottie than ever when he heard the whole story, which she repeated then and there, just as I've told it to you.

## Pen Illustrations of the Drafts.

### DRAG-FRONT COACH.

*Illustrated on Plate XXXII.*

In this design we have connected a drag-front to the coach body; with what success our readers may judge. The manner we have adopted in building up the front on the carriage-part is both novel and pleasing in appearance. The back springs, as shown in the drawing, when thus arranged, impart an easy motion to the carriage; but these should be secured to the iron loops with clips, in order to make them secure and safe. Dispensing with brakes is of course a matter of fancy with manufacturers.

X. Z.

### TILBURY PHAETON.

*Illustrated on Plate XXXIII.*

We call this a Tilbury Phaeton; but with as much propriety we might call it a Tilbury Dog-cart, perhaps, as the character of both are combined. The back quarter

in this example is finished with French imitation of basket-work, which is supplied, in various patterns, by Mr. Chr. Volkert, of 96 Walker street, New York, superior to any imported from Europe, at half the cost. This carriage was in much demand the past season, and probably will be again.

—  
CANED GO-CART.

*Illustrated on Plate XXXIV.*

THIS drawing is similar to that given with our last number, (see Plate XXXI.,) called a Newport cart. The greatest objection to this cart is that, to get the body hanging low enough for convenience, very low wheels must be used, say three feet. This puts a little too much labor upon the horse. The notion may be peculiar to us; but we always like to have the springs *where they can be seen*, as well as so as to be easy riding. In this case an iron loop is used in hanging up, on elliptical springs, and the axle must be "cranked" to give room for the body to play, as will readily be seen.

## Sparks from the Anvil.

### HENRY HARPER'S SCALE AND GAUGE FOR DETERMINING THE PROPER PITCH FOR SETTING AXLES.

PATENTED, NOVEMBER 18, 1862.

*Illustrated on Plate XXXV.*

*Description of the Scale.—Figure 1.*—The line down the middle is the radius of a circle 60 inches in diameter. The lines crossing the radius are arc lines. The figures on the rule denote the distance the arcs are from the centre. The clamp and thumb-screw is to fasten the rule to the place wanted. The edge of the rule is to correspond exactly with the radius line.

*Description of the Gauge.—Figure 2.*—The Gauge is the counterpart of the Scale up to the 12-inch arc. When the radius line is turned to the edge of the clamps, the rests with which the axle-arm is touched to gauge it by, forms a straight line along the points from one end of the Gauge to the other. The crescent-shaped rests are set as far apart as the track of the locality is from centre to centre, and are for the purpose of holding the Gauge from slipping from the axle. The words "IN" and "OUT" have the same meaning as on the scale.

By this invention any carriage or wagon-maker can, in the short space of three minutes, form an exact pattern to try his axle by, when setting the same, so that the bearings will be equal at the shoulder and point of the axle when the wagon is running on level ground. It is warranted to enable the workman to set his axles in a perfect manner, so that no motive-power is wasted thereby.

A long course of experimental study upon the subject has satisfied the inventor of this machine that there is almost an universal lack among the members of the craft, of a correct knowledge on the subject of that his invention is designed to remedy; and the consequence is, that

a very large proportion of the carriages and draught-wagons now made are entirely worthless, compared to what they might be, were the axles set so that none of the motive-power was wasted.

If the patentee is enabled to carry out his wishes, which are, that no unjust monopoly shall be placed on his invention, the time saved to the workman will far more than pay the cost of the machine which he buys, aside from the great value of a reputation for making work that cannot be beat for running easy.

To that class of the community who wear out wagons and carriages, I can say and demonstrate conclusively that there is a loss, by the fault of not setting axles properly, of more than one hundred dollars, in the waste of motive-power, on nine-tenths of the wagons that are now made.

This enormous amount the consumer has unnecessarily taken from him, in team-work, before his wagon is worn out, by the universal want of an invention similar to the one now offered. To secure the full amount of the benefit intended, the customer also has a part to perform. Ask the mechanic, of whom you are about to purchase a carriage, or draught-wagon, if he reads the literature which is, and has been, periodically published, directly in reference to his trade, by the Editor of THE NEW YORK COACH-MAKER'S MAGAZINE, the only paper devoted entirely to the trade in the United States. If he cannot answer you satisfactorily, look upon him as you would upon the lawyer or doctor who has discarded the use of books, after learning their profession. In either case, the parties will be lacking in the science which their fellow-craftsmen are daily developing, and which it is absolutely necessary for your interest that he should possess.

Terms for a machine, with the right to use the same in any one shop designated, in the United States, \$25. They will be carefully packed, with full printed instructions for using the same, and forwarded to order by express, or otherwise, as may be directed, at the expense of the purchaser. Express charges will be from \$1 to \$1 25, according to the distance sent.

Letters of inquiry, to secure an answer, must contain a stamp for return postage. Address,

HENRY HARPER, Berlin, Wis.

### DRAUGHT OF CARRIAGES.

ONE of the causes of the difference in the draught of carriages made on the same principle, of the same size, and the same weight of materials, arises from the mode in which the axle-trees are made. An idea exists that the front of the wheels should be narrower across than at the back, and this is done by setting the arm on each side slightly forward, at the point or screw end of both front and back axle-trees. Formerly, this was invariably done; and even now many old-fashioned carriage-makers attend the smith, when practicable, for having it truly done. The result is, that the wheels have always a tendency to run towards the center, each of itself, in the line of draught onwards, creating a degree of sliding on the ground, and an unfair lateral pressure on the box, on all the four bearings of the carriage. This is equally injurious to the wear of the wheel. The dip of the arm to throw the top of the wheel out is quite sufficiently disadvantageous to the draught, and this it would also be desirable to omit, but for the fact of its being necessary to throw the dirt collected by the rotary motion of the wheel away from the

carriage body. Could the axles be made perfectly straight, that is, the arms quite parrallel with the ground, and in exact right angles with the line of draught, which is a line drawn from the point of the pole to the center, between the hind wheels, and each arm cylindrical and case-hardened, the carriage would run much more easily. In that case the wheels would require to be upright.

This rule especially holds good with respect to two-wheel carriages; every dip of the arm adds to the labor of draught. It may easily be understood that as the horse at each step raises the shafts suspended to his back, so does he drag forward the point of the arm, and slightly lift it up on each side; and with it the wheels at each lift curve inwards; whereas, with the arms perfectly straight every way, the shafts would act on the boxes in the same manner as a hinge, and the movement of the wheels would be uniformly straight forward, following the impetus given to the horse, without interruption. This was once pointed out by the writer to a celebrated axle-maker, who was so convinced of its truth that he invariably adopted it for his own use, and also recommended it to others, declaring that his gig ran more easily, his horse was less tired, and the oil remained longer in the boxes.

#### RENDERING WORN-OUT FILES AGAIN USEFUL.

To accomplish this, the *London Builder* says that a Liverpool firm first place their old files in a bath containing alkali, such as soda. This having removed all grease, they are afterwards washed in warm water, and then placed in a bath of dilute nitric acid, and agitated. On removal from this bath, they are again washed in water, and placed in the acid bath again, which is renewed by adding some fresh nitric acid and some sulphuric acid. In this the files are allowed to remain until they are sufficiently acted upon—rendered sharp—when they are washed in hot water, dried and oiled for use. The difference between this and a well-known method of treating old files, consists in the use of nitric instead of dilute sulphuric acid exclusively. Files thus heated do not last as long afterwards as when freshly cut.

### Paint Room.

#### COLORS—PERMANENT AND FUGITIVE.

WE condense, for our pages, the following from the *London Chemical News*, as far as they will profit our readers. Artists' colors may be classed as inorganic and organic, and described as permanent or fugitive, transparent or opaque. Their transparency or opacity, however, are more strictly artistic qualities, and need not be remarked upon here. As is their due, those pigments have precedence which are permanent, whether obtained from metals and earths, or from the vegetable and animal worlds.

##### PERMANENT PIGMENTS.

**INORGANIC YELLOWS.**—*Cadmium Yellows* are obtained from cadmium and sulphur. Being sulphides, they are not affected by impure air, and the deep gorgeous varieties may in other respects be safely relied upon. Those of a pale, lemon hue should be regarded with suspicion. There were several samples of that tint shown at the International Exhibition, both by foreign and British color-makers, but

all, without exception, became, I noticed, gradually coated with white.

*Lemon Yellow*, produced from barium and chromium, when skilfully prepared, is a safe, reliable color. Unlike chromates in general, it is not sensibly altered either by light or a foul atmosphere.

*Mars Yellow* is an artificially prepared ochre, of which the chief constituents are iron, silica and alumina. When pure, it is a most stable pigment, of a clear, sober, gravel tint.

Except with respect to color, the same remarks are applicable to the native iron earths, such as yellow ochre, Roman ochre, &c.

**ORGANIC YELLOW.**—*Cyanogen Yellow*, in the preparation of which, as its name denotes, cyanogen in some form or other is employed, was one of the many new pigments first introduced to the public by Messrs. Winsor and Newton at the last Exhibition. Of a gorgeously golden hue, it may claim to be our only permanent organic yellow. Less opaque than the cadmiums, it is quite as durable, and equally unaffected by sulphuretted hydrogen.

**INORGANIC REDS.**—*Indian Red* is a dark peroxide of iron, of a purple-russet hue, brought, it is said, from Bengal. This nature-furnished pigment is but little altered either by light, time, impure air, or mixture.

*Light Red, Venetian Red, &c.*, are iron ochres, either native or artificially prepared. Clear, though not bright in tint, they are most stable colors.

*Vermillion*, composed of mercury and sulphur, is the only brilliant inorganic red (iodide of mercury excepted) at present known, and the only permanent scarlet which the art world possesses. If true, neither exposure nor a foul atmosphere sensibly affect it.

**ORGANIC REDS.**—*Madder, Carmine, Rose Madder, &c.*, are preparations of alumina or its compounds, stained more or less deeply with the red coloring matter of the madder root. When skilfully made they are not liable to change by the action of either light or impure air, or admixture.

##### FUGITIVE PIGMENTS.

**INORGANIC YELLOWS.**—*Chrome Yellows*, products of chromium and lead, become black by impure air, and cannot well be employed in admixture, ultimately destroying (for example) Prussian Blue, when used therewith in the composition of greens.

*Chromate of Cadmium*, made from chromium and cadmium, is not sensibly affected by sulphuretted hydrogen, but soon greens by exposure. The very slight affinity which chromic acid has for cadmium, and the too great solubility of the chromate in water, render it ineligible as a pigment. A bright pale yellow, inclined to transparency, and not long introduced.

*Naples Yellow*, if true, is a compound of antimony and lead, and cannot be relied upon. Now, however, the color sold under that name is sometimes nothing more than zinc-white tinted by cadmium yellow, in which case its permanency is unquestionable.

**ORGANIC YELLOWS.**—*Gamboge*, a yellow gum obtained from Indian trees, and collected in a liquid state and dried, may be called a semi-fugitive pigment. Deepened by impure air, weakened by light, and injured by many metal-line colors, gamboge is yet too useful to be dispensed with. It is especially serviceable as a glaze over other colors in water, when its resin acts as a varnish which protects them.

*Indian Yellow*, a urino-phosphate of lime, produced

from the urine of the camel, is injured by light, air, and a foul atmosphere, and injures cochineal lakes, when used with them.

**INORGANIC REDS.**—*Pure Scarlet*, a combination of iodine with mercury, is at once the most vivid and the most treacherous of all colors, and cannot be relied upon in the slightest degree. By exposure the scarlet vanishes altogether, leaving a pure white ground. By impure air the color is utterly destroyed. When used in water, gum ammoniac or a glaze of gamboge are advantageous accompaniments.

*Red Lead*, a deutoxide of lead, is blackened and ultimately metallized by sulphuretted hydrogen, although, if pure, not liable to be altered by light.

**ORGANIC REDS.**—*Lakes of Cochineal*, aluminous bases stained with the coloring matter of the insect—*coccus cacti*—comprise crimson lake, carmine, &c., and are unrivaled in their richness and beauty. Far surpassing the madder preparations in depth and brilliancy, they are as much inferior to them in permanency, their color being quickly discharged by exposure to the light.

**INORGANIC BLUES.**—*Antwerp Blue* is a lighter and brighter Prussian Blue, containing a larger excess of alumina, but possessing all the qualities of

*Prussian Blue*.—This blue, being compounded of iron, alumina, and ferro-cyanogen, may be called a semi-organic pigment, and described as semi-fugitive. Though its tints fade by the action of strong light, and are darkened by damp or impure air, yet, when used in deep washes, its body somewhat secures its permanence, and its transparency gives force to its depth.

**ORGANIC BLUES.**—*Indigo*, the produce of several East and West India plants, is injured by impure air, and in other respects is inferior in durability to Prussian Blue.

*Intense Blue* is indigo refined by solution and precipitation. The process renders it rather more durable than before, and much more powerful and deep. It is apt, however, when not well freed from the acid and saline matter used in its preparation, to penetrate the paper on which it is employed.

**INORGANIC GREENS.**—*Scheele's Green*, a rankly poisonous compound of arsenic and copper, may fairly be called the most popular and best abused of all inorganic colors. Although blackened by impure air, the palette, at any rate, could ill do without it, for, when required, no mixture will serve as a substitute. As vivid in its way as iodide of mercury, it immediately attracts the eye to any part of a picture in which it may be placed. Non-artistically speaking, the lavish employment of this dangerous color for painting toys, the leaves of artificial flowers, and paper-hangings, and for mechanically dyeing thin gauzy dresses, may well be regretted. Much nonsense has been written about this green being prone to volatilize, and much good sense about its liability to become detached, to drop or be brushed off, and so to float about in the atmosphere. For toys, at least, this pigment should never be used, and people would do considerable service by refusing to buy them if suspiciously bright in color. It is one of the pleasures of childhood, a pleasure no child can resist, of sucking or biting anything and everything which comes in its way. If, therefore, the attractively green handle of a roller or what not becomes suddenly shabby, it may be taken for granted that a certain amount of arsenic has been rapturously swallowed by its little owner. For ourselves, if we must have poison on our heads, our clothes, and our

walls, means should be taken of securely fixing it by a proper proportion of albumen or other suitable substance. In the case of paper, perhaps a glaze of gamboge might be found advantageous, that pigment being, as has been before remarked, "especially serviceable as a glaze over other colors in water, where its resin acts as a varnish which protects them." For the rest, until a new color equally vivid and equally cheap is discovered, this preparation of arsenic will continue in use. The only way is to limit that use as much as possible, and to find out the best and safest mode of employing it.

There are also several other copper products, such as verdigris, mountain green, &c., but as pigments they are all too fugitive to be safely employed.

**ORGANIC GREEN.**—*Prussian Green* may rather be classed as organic than inorganic, inasmuch as it is now generally a mixture of gamboge with Prussian Blue, itself containing cyanogen. It is neither permanent nor very unstable.

**INORGANIC ORANGE.**—*Chrome Orange*, obtained by the action of an alkali on the yellow chromate of lead, is liable, though in a somewhat less degree, to the changes and affinities of that substance.

**ORGANIC ORANGE.**—*Chinese Orange*, produced, it is said, from aniline, is of a rich, sober, orange-russet color, and is very transparent. It is unfortunately blackened by sulphuretted hydrogen. Quite new.

**INORGANIC PURPLES.**—There are no fugitive inorganic purples in common use, except those made by mixing red and blue.

**ORGANIC PURPLES.**—*Burnt Carmine* is the carmine of cochineal partially charred. In color it resembles the purple of gold, but not in durability, being, like carmine itself, fugitive.

A want of permanency is likewise possessed by the other cochineal purples, purple lake and violet carmine.

**INORGANIC BROWNS.**—*Cadmium Brown*, prepared by igniting carbonate of cadmium, was shown for a short time in the International Exhibition—for a short time, because it had to be speedily withdrawn on account of its rapid whitening, which takes place in this way: When the white carbonate of cadmium is thoroughly burnt, it becomes converted into the brown oxide, or cadmium brown. By exposure, this brown oxide eagerly absorbs carbonic acid from the atmosphere—so eagerly, that in a few weeks it is once more a carbonate, and as purely white as before. This utterly worthless preparation is opaque, and of an agreeable yellow-brown tint.

**ORGANIC BROWNS.**—There are too many browns permanent, whether inorganic or organic for fugitive preparations, to be usually employed.

**INORGANIC AND ORGANIC BLACKS.**—No fugitive blacks are now used.

**INORGANIC WHITES.**—*Lead Whites* are mostly carbonate of lead, and are sold under various names, such as flake white, cremnitz white, &c. They are all blackened by sulphuretted hydrogen, and are injurious to cochineal lakes, gamboge, orpiment, &c.

**PEARL WHITE**, prepared from bismuth, turns black in impure air. It is chiefly used as a cosmetic by ladies, to whom an atmosphere free from sulphuretted hydrogen is especially desirable.

**ORGANIC WHITES.**—There are no fugitive as there are no permanent organic whites.

COMPOSITION OF PAINTS came too late for this number.

## Trimming Room.

### GOSSIP FOR THE TRIMMER.

WITH the rise in the premium on gold, the price of almost everything required in trimming carriages will advance, as payments for goods imported from abroad must be made in that coin. For these reasons, prudence will dictate that our friends be on the alert and secure their stock required for the Spring business, before the demand for such sets the dealers crazy in demanding exorbitant prices, even beyond the requirements of a fair business transfer, to customers. Prices quoted for cloths last month are firmly maintained this; and we have no doubt that the stock, *in transitu* from Europe, will seriously advance in price. We say *seriously*, because every advance in material seriously affects the interests of the craft.

With the New York *elite*, at present the most fashionable carriage is the Coupé. For trimming these, Repps, Cotelines and Satins, &c., are in request; and nearly every color known to the dyers is used, but the most popular are blue, brown, and maroons. Just now, a limited stock might be purchased at reasonable prices; but the new importations, like the cloths, must command advance prices to pay the importer.

A new article, made from a fibrous material, is coming into some use as a substitute for moss, for stuffing cushions, &c.; but why it should, is a mystery we cannot solve at the present low price for the latter article. The very best moss we have ever seen can now be had by the bale for 10c., notwithstanding the predictions of croakers that the war would cause a scarcity of the article, and put up the price to a high figure. The high price asked for curled hair forbids the use of it as extensively as formerly; still, first quality of work requires its use in many portions of the trimmer's labor, and cannot therefore be dispensed with.

### DIRT-SCREENS OVER CARRIAGE WHEELS.

A LATE number of *Newton's London Journal of Arts*, gives the reader a description, accompanied by an illustration of Wycherly's invention, having for its object the prevention of the vibration commonly imparted to the wings or dust-screens over the wheels of pleasure carriages, arising from the mode commonly adopted of attaching the parts to the bodies of carriages above the springs. This English improvement (if such?) is effected by attaching independent auxiliary springs, either outside or inside, above or below the springs, used for supporting the carriage body; and to the ends of these auxiliary springs are formed extensions that support the wings. These screens are brought in close contact so as to cover the upper section of the wheel; and yet allow of its rotating freely when traveling, something after the mode we have seen adopted in locomotives, except that in these cases, metal alone supplies the place of an iron frame and leather, as in pleasure carriages. We give this information, as we do many other things, that our readers may judge of its utility for themselves.

TESTING BLUES IN CLOTH.—A correspondent informs us that nitric acid is a good thing for testing blues in cloth. Should the colors be genuine indigo, the acid changes the color of the cloth to orange; if not, to a red color.

## Editor's Work-bench.

### SLOW COACH-MAKERS.

THERE are some coach-makers, so *very* economical, that they think they cannot afford to invest four dollars in a Magazine, even when it is devoted to their special interests. They do not see that, by following such a course, they are committing business-suicide. They are content to jog along, as their fathers did years ago, old-fogy like, while their neighbors, more wise, avail themselves of all the information they can obtain from scientific publications, and succeed in getting up a superior class of work, whereby they generally monopolize the entire custom of the locality worth having. Such *enterprise* as these slow coach-builders exhibit, generally leaves them in a short time to settle with their creditors, with a small per centage on their indebtedness. They "can't see" any use in "book larnin'," and give all counsellors for such, the cold shoulder, with the common assertion, which no one disputes—that "it requires experience to make a good carriage-maker."

How these "slow coach-makers" get along, is well illustrated by an extract from one of our friend Harper's letters to us. He says: "I am pleased with the effect my Gauge is having on some wagon and carriage-makers at R—, who refused to buy of me. I sold the town right to others. Now those who would naturally be their customers, go to some one of the four shops surrounding them where I have sold the Gauge. Some time ago, I got an order for a wagon, where they would have to come six miles beyond R—, to Berlin. It was a rich farmer, whose custom they were loth to lose, so they offered to build him a wagon for \$75, that W. would charge \$85 for. I had some anxiety about who would get the job. W— finally got the order, which, with some extras, came to \$90. Three rich farmers in the immediate vicinity, having the importance of a good running wagon fully impressed upon their minds, have since given Mr. W— their orders.

"A connection of circumstances attending this transaction shows the importance of having your Magazine as well as my Gauge understood by those directly and indirectly concerned. The first part of 'The Motive-power of Wheel-carriages' was condensed and published in *The American Agriculturist*. The estimated loss by a hard-running wagon took the attention of this farmer, and he mentioned it to me in a conversation with him. I explained to him, and showed the Magazine that the article was copied from. It established his confidence in my recommendation of a good wagon, so that \$10 would not induce him to have any other. \* \* \* To tell what I actually think, is this: *those who think they stand at the head, have degenerated down in the line of mechanism to merely making a superficial show.*" In other words: those who think they know all about their business without resorting to study,



generally know very little about the scientific part of it. These are, emphatically, slow coach-makers. One fact is certain—where two shops are found in a village, the one where our Magazine is steadily taken has always the best work, and consequently the best run of customers. We have seen this wherever our travel has taken us, and the same is amply confirmed by the observation of many others, who have gone abroad as our agents.

#### UNREALIZED HAPPINESS.

At a very early period in the history of this city, a worthy coach-maker established himself in a down-town street, not far from the corner of Broadway, where, by industrious perseverance, he accumulated a respectable competence, and a high position among the people of that day. There seemed to be only one *weak* spot in his organization: that was too great an indulgence towards his children—in fact these were left to grow up without much restraint, doing pretty much (after the common saying) “as they had a mind to.”

Among the male portion of this family circle was one individual more enterprising than the others, who having a little knowledge of his sire's trade, vainly hoped that, by carrying on the business, as successor to his father, he might swell the amount left as his portion of the father's estate, and so become a rich nabob. Instigated by such hopes, the individual referred to set-up for himself with plenty of means; but, as the sequel disclosed, with an indifferent amount of judgment to conduct a business which many men, of far greater sagacity and much more forethought, often find themselves too illy qualified successfully to manage. In his case, it would have been far better for our hero had he been more thoroughly trained in the school of industry and compelled to eat the bread of toil.

The general experience of business life is, that, in nine cases out of ten, those who commence the carriage-making business on a small capital, backed by energy, are more certain of success than those who are started by the liberality of friends, or the gifts of fortune. When wealth and experience increase together, things seem to progress safely. He who by experience knows how hard it is to gather a competence, generally knows how to take care of his earnings afterward. In addition to that left him by his father, our hero considered himself lucky in marrying another fortune; and so he might have been, had he been properly educated to use it advantageously. The gifts of fortune, in his case, only made him uneasy; and spurning the cares of business life, his highest ambition was for some retired spot, whereon, in imitation of feudal lords, he might erect a castle, and gather around him a company of retainers.

In this dreamy state of mind “our brother” selected a spot some thirty miles from this city, at a point where ocean and river mingle their waters in one common wave,

and musically beat upon a pebbly shore. In reaching this ideal paradise, the eye rests upon an extensive panorama of bay and inlets, studded everywhere with the shipping of all climes, and unsurpassed in beauty by none in the world. In the spot above alluded to, was erected Rosscastle, in all the splendor of modern architecture; but to this castle, “distance lent enchantment to the view.” A nearer inspection showed that the castle, erected entirely of wood, and standing on a treacherous foundation, was more fancifully conceived than durably carried out. Two enormous clock towers, constructed after a doubtful style of architecture, sprung up at each facial angle, so high in mid air as to need only a sprinkling of rooks and daws, and a little fanciful imagination, to create a picture of the baronial castles of former times in England. In a lower compartment of one of these lofty towers, was formerly placed an extensive library, or at least accommodation was made for such; in the corresponding locality in the other tower, was arranged the household crockery “all in a row,” but which at the time of our inspection presented the appearance of that described by Goldsmith in “The Deserted Village.” The eastern wing of the castle was completed for the purpose of a church, with pulpit and galleries, in the Gothic style, and arches extending high up above the worshippers. This was done to please the Lady of the Manor, whose high church notions forbade her mingling with the less pretending worshippers at the village sanctuary. The western wing was arranged as a ball chamber for the merry dancers, (Oh consistency, &c.), in direct communication by a door, with the other wing. In the back-grounds of all flowed an artificial lake, the waters of which were stocked with fish of various kinds, and in which appeared miniature islands and snug castles, reached by artistic-looking bridges, under which gondolas, &c., were rowed. Around all these were planted trees of many varieties. To describe everything about this castle would require more space than we can find here to do; we therefore leave the remainder to imagination.

Everything having been prepared and set in motion, the occupant, no doubt, expected to have nothing to do but dream out life's voyage; but, although to the outside world matters went on *swimmingly* at the castle, by this time they did not go right at the carriage-shop, in the city. The lack of proper oversight from the proprietor, and the consequent inattention to customers, soon scattered them to other shops of more attentive mechanics, and with them, too, went one important means for furnishing the “lordly institution” with the necessary amount of revenue for keeping the wheels moving. Under such circumstances, it is not to be wondered at that “our brother” woke up when he found his creditors clamoring at the castle doors for the amount of their bills. He put them off as long as possible, but determined importunities finally dispelled his dreams of earthly happiness, and landed him for a season in the

lock-up, where he found time for reflection "on the vanity of all human wishes."

As for the castle, that was soon after deserted by the lady and retainers, who sought refuge from the storm in distant quarters of the compass. Neglect and time soon did their work. Any reader who may be voyaging to Amboy, from this city by water, through Staten Island Sound, will recognize the pile to which this brief sketch refers, and see for himself "The monument of a Coach-maker's Folly."

#### WIND-POWER FOR MACHINERY.

OUR wide-awake friend, S. EDWARDS TODD, Esq., sends us the following article on this subject, which may be worthy the attention of some of our country subscribers:

In localities where water-power is not available, the wind would furnish sufficient power to drive all the machinery that a carriage-maker might need. In Cayuga County, New York, there are several wind-mills in successful operation. In the vicinity of Auburn, N. Y., there is a wind-mill which drives a turning lathe, and a circular saw twenty-two inches in diameter, for sawing fire-wood, and which is doing a good business. When there is a good wind, it will saw wood as fast as it can be handled and put upon the feeding-table.

Another such power is now being built in the city of Auburn for the purpose of driving a large turning-lathe, circular saw, up-and-down saw, a grindstone, and a boring-machine. The wings will be self-adjusting, and the motion will be regulated by two conical drums, by which means a velocity of from one hundred revolutions per minute to three thousand may be obtained, without stopping any part of the machinery, simply by running the belt on the conical drums, from one end to the other, with a belt set.

#### HOBSON'S LIVERY STABLE.

ALMOST everybody is familiar with the term "Hobson's choice;" few, however, know its full meaning, or on what it is founded. An explanation appears in number 509 of *The Spectator*. The story reads thus: Mr. Tobias Hobson was a carrier, and being a man of great abilities and invention, and one that saw where there might profit arise, though the duller men overlooked it, this ingenious man was the first in this Island (Great Britain) who let out hackney horses. He lived in Cambridge, and observing that the scholars rode hard, his manner was, to keep a large stable of horses, with boots, bridles, and whips, to furnish the gentlemen at once, without going from college to college to borrow, as they have done since the death of this worthy man. I say Mr. Hobson kept a stable of forty good cattle, always ready and fit for traveling; but when a man came for a horse, he was led into the stable, where there was great choice; but he obliged him to take the horse

which stood next to the stable door, so that every customer was alike well served according to his chance, and every horse ridden with the same justice. From whence it became a proverb, when what ought to be your election was forced upon you, to say "Hobson's choice." This memorable man stands drawn in fresco at an inn (which he used) in Bishopsgate Street, with a hundred-pound bag under his arm, with this inscription upon the said bag:

"The faithful mother of a hundred more."

Whatever tradesman will try the experiment, and begin the day after you publish this, my discourse, to treat his customers all alike, and all reasonably and honestly, I will insure him the same success. Milton wrote two epitaphs to his memory, of doubtful honor. One of these reads thus:

"Here lies old Hobson; death hath broke his girt:  
And here alas! hath lain him in the dirt;  
Or else the ways being foul, twenty to one,  
He's here stuck in a slough and overthrown."

#### LITERARY NOTICE.

THE ATLANTIC MONTHLY.—The thirteenth volume of this able American periodical begins with the January number. Steadily increasing in popularity, since its present publishers, Messrs. Ticknor & Fields, assumed its management, it has now a circulation greater than that ever reached by any American magazine of its class, and numbers among its regular contributors such names as Longfellow, Hawthorne, Emerson, Bryant, Agassiz, Holmes, Lowell, Harriet Beecher Stowe, Whittier, and others scarcely less eminent. Its stereotyped volumes are a valuable repository of original papers on a very great variety of subjects, and its monthly issues have a genuine freshness and fitness to the hour. If it is a good test, as it certainly is, of the standing of a Magazine that it attracts and introduces new writers, the names of Higginson, of Gail Hamilton, and of the lamented Winthrop, are evidence enough of what the *Atlantic* has thus accomplished. Nor can a better proof be given of the popular estimation in which it is held, than the demand for a publication in separate volumes of many of the serial papers that first appeared in its pages.

As among the chiefest merits of the *Atlantic*, also, let us not forget that it has honestly held and freely declared its own opinions, on other than literary questions, and that while it has won for itself in literature a position which no other American Magazine has reached, it has constantly spoken true words for Liberty and Progress. In the present crisis through which the country is passing, every intelligent American should know what influences such minds as those of the contributors to the *Atlantic* are exerting upon the progress of humanity. Single subscriptions, \$1 per year, postage paid.

#### FOREIGN IMPROVEMENTS IN CARRIAGES.

OMNIBUSES AND OTHER LIKE CARRIAGES.—January 15, 1863. J. P. Bath, of Aigburth, near Liverpool. These improvements have for their object a simple arrangement whereby omnibuses and other like vehicles are rendered equally available for traveling upon rail or tramways or

common high roads, and they consist in suspending by joints to the under side of the "fore carriage" two short, pendulous arms, to the lower ends of which are attached axletrees running parallel with the main axletree on the outside of these arms, and carrying thereon vertical revolving faceplates, to the front of each of which is secured a disc, annular ring, or wheel, which, extending a short distance beyond the ordinary running wheels, acts as a flange for keeping the bearing wheels on the rails. The inner ends of the axletrees, on the inside of the pendulous arms, the inventor prefers, for the sake of strength, to bend upwards, and he attaches them to the centre of the main axletree by a suitable joint or joints. When the guides are in use, they are held in position by india-rubber or helical springs attached on each side to the lower end of the pendulous arms and to the ends of cross-beams or arms extending across the main axletree. When the carriage is required to run on the ordinary road, the guides are drawn up (by preference in a backward direction) by means of a bridle-chain or cord and small windlass, or other mechanical equivalent, worked by the driver for other person.

**CONSTRUCTION OF AND MODE OF APPLYING WINGS OR DIRT SCREENS OVER THE WHEELS OF CARRIAGES.**—Feb. 14, 1863, H. Wycherly, Oldbury, Worcester, England.—The patentee claims the "distinct" use of auxiliary springs, secured to the axle, for supporting the wings or guards of carriages, in contradistinction to their being supported or connected with the bodies of such carriages.

**AN IMPROVED OMNIBUS.**—C. D. Abel, Southampton Buildings, Chancery Lane, London.—The patentee claims the construction of Omnibuses having a double body, or two compartments side by side, and carried by two sets of three wheels, one of each set being of a large diameter, and placed centrally, so as to run in grooves formed between the two compartments. By this arrangement an omnibus is formed which, if of the ordinary length, will be of double the usual capacity, and yet require considerably less tractional force in proportion to the increased load, than an omnibus of ordinary construction, as the wheels are so arranged that the weight is carried equally by the front and hind set, added to which the large size of the central wheels greatly facilitate the easy motion. In order to facilitate the turning or lateral motion of the omnibus, the axles of the front, and, when required, the hind outside wheels, are arranged to turn upon centers, the front central wheel also partaking of this motion. The turning of the axles of the hind wheels, when required, is effected by the motion of the front wheels, by means of diagonal connecting rods hinged to the axles, similar in arrangement to those already employed for railway carriages and traction engines. It enables the outer wheels to shift their position. The points of support of the springs work in grooved or slotted segments attached to the body of the omnibus, which is also the case with the front central wheel. Both the central wheels are fixed upon short axles, which run in bearings on either side of the wheel; the outside wheels turn upon their axles in the usual manner. A separate door is provided to each compartment of the body, both of which compartments are provided with two rows of seats, and are either entirely partitioned off from each other, or only partially so. Two double rows of seats are arranged on the roof, to which access is gained by steps fixed at the back between the two compartments. The omnibus

is arranged to be drawn by three horses abreast, and are expected to draw twice the ordinary number of passengers.

#### AMERICAN PATENTED INVENTIONS.

Sept. 29. **AXLE-BOX FOR VEHICLES.**—S. F. Green, of Croton Falls, N. Y.: I claim the combination with the two parts of the divided box, D, axle, A, and nut, B, of the nut, E, in the manner and for the purpose herein shown and described.

**NECK-YOKE AND WHIFFLE-TREE.**—A. S. Dow, assignor to himself and E. W. Wilcox, of Cederville, N. Y.: I claim the combination of the leather or other packing, D, with the ring, B, made in two parts and united by the screws, *d d' d'' d'''*, or their equivalents. And I also claim the combination of the tubular or cylindrical portion made in two parts, as described, with either a neck-yoke or whiffle-tree, substantially as and in the manner set forth.

October 6. **FELLY MACHINE.**—Robert Massey, of Philadelphia, Pa.: I claim, *First*, Two reciprocating saws, L and L', in combination with the devices herein described, or the equivalents to the same for holding the plank, and causing the same to move in the arc of a circle for the purpose specified. *Second*, The blocks, *i i' i'' and i'''*, arranged for securing the saws and adjusting the same on the saw frame to suit felloes of different sizes, substantially as set forth. *Third*, The reciprocating saws, L and L', in combination with the table or platform, M, and rollers, P, the whole being arranged and operating substantially as and for the purpose described. *Fourth*, The adjustable and yielding arm, *p*, when arranged in respect to the saws, and for bearing on the plank, substantially as set forth. *Fifth*, The weighted arm, T, with the roller, *u*, when arranged for bearing on the plank, substantially as described for the purpose specified. *Sixth*, The rack, 20, furnished with the jaws herein described, or their equivalents, for holding the plank, in combination with the sliding-frame, 13, and shaft, 12; the whole being arranged to so operate that the rack can be moved forward definite distances, and at the same time be so turned that the plank can be moved in the arc of a circle as described. *Seventh*, The adjustable stops, 17 and 18, and rack, 20, in combination with the pawl, 28, and the intermediate devices or their equivalent whereby the said stops are caused to operate the pawl, and move the rack in the manner described. *Eighth*, The lever, 33, arranged and operating for locking the rack, substantially as described. *Ninth*, The sliding-block, 50, arranged and operating for maintaining the lever, 33, out of gear with rack during a portion of the movement of the machine as set forth. *Tenth*, The arm, 30, its hinges, 40 and 41, when arranged for operating the weighted lever, 43, and through the latter and other appliances herein described, or their equivalents for reserving the motion of the plant.

Oct. 20. **SHAFT-COUPLING.**—Thomas S. Lambert, of Peekskill, N. Y.: I claim the combination of the caps, D'D, either or both in combination with the bolt, F, in the manner and for the purposes as substantially set forth.

Oct. 27. **IMPROVED WAGON-STANDARD.**—O. E. Miles, of Aurora, Ill.: *First*, I claim a cast metal upright for vehicles, adapted to be secured against lateral and end movements upon the bolster, substantially in the manner and for the purpose herein set forth. *Second*, I claim the specific arrangement of the several parts in the base of my said upright, the lip or flange being adapted to project down on both sides and at the end, and the part, *a'*, being let into the top of the bolster, B, at some distance from the end, all as herein set forth.

**IMPROVED SLED.**—S. E. Oviatt, of Richfield, O.: I claim the use of cast-iron sled knees, having pipe sockets in the upper parts thereof for the reception of the ends of the sled beams, when constructed and arranged substantially in the manner and for the purposes herein described.

**IMPROVED SPOKE-SHAVE.**—Melzer Tuell, of Penn Yan, N. Y.: I claim the stock, A, and cutter, B, when constructed and arranged as and for the purpose set forth. *Second*, I claim the adjustable gauge, C, when made and used as specified.

## CURRENT PRICES FOR CARRIAGE MATERIALS.

NEW YORK, January 20th, 1864.

Apron hooks and rings, per gross, \$1.25.  
 Axle-clips, according to length, per dozen, 75c. a \$1.  
 Axles, plain taper, from  $\frac{3}{4}$  to 1 in., \$6;  $1\frac{1}{2}$  in., \$6;  $1\frac{1}{4}$  in., \$6.50.  
 Do. Swelled taper, 1 in. and under, \$6;  $1\frac{1}{2}$  in., \$7;  $1\frac{1}{4}$  in., \$8.50;  $1\frac{3}{8}$  in., \$10;  $1\frac{1}{2}$  in., \$12.  
 ☞ These are a superior axle, and more frequently called for than any others.  
 Do. case-hardened, half-patent, \$7.50; do. \$8.50; do. \$9.  
 Bands, plated rim, under 3 in., \$1.88; over 3 in., \$2.50.  
 Do. Mail patent, \$2.50 a \$3.25.  
 Do. galvanized,  $3\frac{1}{2}$  in. and under, \$1; larger, \$1 a \$2.  
 Basket wood imitations, per foot, 88c.  
 ☞ When sent by express, \$2 for a lining board to a panel of 12 ft.  
 Bent poles, each \$1.12 $\frac{1}{2}$ .  
 Do. rims, under  $1\frac{1}{2}$  in., \$2.25 per set; extra hickory, \$2.50 a 2.75.  
 Do. seat rails, 44c. each, or \$4.50 per doz.  
 Do. shafts, \$6.  
 Bows, per set, light, 85c.; heavy, \$1.12.  
 Bolts, Philadelphia, add 20 per cent. to printed list.  
 Do. T, per 100, \$3 a \$3.50.  
 Do. tire, \$1.25 a \$1.80 a \$2.40, according to size.  
 Buckram, per yard, 30c.  
 Buckles, per gross, 88c. a \$1.25.  
 Burlap, per yard, 25c.  
 Buttons, japanned, per paper, 15c.; per large gross, \$1.50.  
 Carriage-parts, buggy, carved, \$4.  
 Carpets, Brussels, per yard, \$2; velvet, \$2.75 a \$3; oil-cloth, 60c. a 80c.  
 Castings, malleable iron, per lb, 15c.  
 Clip-kingbolts, each, 35c.  
 Cloths, body, \$3.75 a \$4.50; lining, \$2.25 a \$3.25. (See *Enameled*.)  
 ☞ A Union cloth, made expressly for carriages, and warranted not to fade, can be furnished for \$2 a \$2.25 per yard.  
 Cord, seaming, per lb, 25c.; netting, per yard, 5c.  
 Cotelines, per yard, \$6 a \$8.  
 Curtain frames, per dozen, \$1 a \$1.50.  
 Do. rollers, each, 75c. a \$1.  
 Dashes, buggy, \$1.75.  
 Door-handles, stiff, 50c. a 63c.; coach drop, per pair, \$2 a \$3.50.  
 Drugget, felt, \$1.62.  
 Enameled cloth, 5 qrs., 75c.; 50 in., \$1.55.  
 Enameled linen duck, 4 qrs., 55c.; 5 qrs., 75c.; 52 in., 90c. Colored, 15c. higher per yard.  
 Felloe plates, wrought, per lb, all sizes, 18c.  
 Fifth-wheels wrought, \$1.38 a \$2.  
 Fringes, festoon, per piece, \$1.75; narrow, per yard, 18c.  
 ☞ For a buggy top two pieces are required, and sometimes three.  
 Do. silk bullion, per yard, 35c. a 75c.  
 Do. worsted bullion, 4 in. deep, 35c.  
 Do. worsted carpet, per yard, 6c. a 10c.  
 Frogs, 38c. per pair, or \$1.63 per dozen.  
 Glue, per lb, 25c.  
 Hair, picked, per lb, 50c.  
 Hub-borers (Dole's) for light work, \$15; heavy, \$18 a \$20.  
 Hubs, light, morticed, \$1; unmorticed, 75c—coach, morticed, \$1.50  
 Japan, per gallon, \$4.75.  
 Knobs, English, \$1.75 a \$2.  
 Laces, broad, silk, per yard, 85c.; narrow, 12c. to 15c.  
 Do. broad, worsted, per yard, 37 $\frac{1}{2}$ c.  
 Lamps, coach, \$14 a 18.  
 Lazy-backs, \$9 per doz.  
 Leather, collar, dash, 27c.; split do., 17c.; enameled top, 27c.; harness, per lb, 45c.; flap, per foot, 15c. a 20c.  
 Linen, heavy, a new article for roofs of coaches, 55c. a 70c. per yard.  
 Moquet,  $1\frac{1}{2}$  yards wide, per yard, \$5.50  
 Moss, per bale, 10c.  
 Mouldings, plated, per foot, 12c. a 15c.; lead, door, per piece, 30c.  
 Nails, lining, silver, per paper, 6c.; ivory, per gross, 25c.  
 Name-plates.  
 ☞ See advertisement under this head on 3d page of cover.  
 Oils, boiled, per gallon, \$1.50.  
 Paints. We quote white lead, extra \$3; Eng. pat. black, 25c.  
 Pekin cloth, per yard, \$2.  
 ☞ A very good article for inside coach linings.  
 Plushes, per yard, \$2 a \$3.  
 Pole-crabs, silver, \$5 a \$6; tips, \$1.12.

Rubbing stone, per lb, 12c.  
 Sand paper, per ream, \$3.75.  
 Screws, gimlet.

☞ Add to manufacturer's printed lists 20 per ct.

Do. ivory headed, per dozen, 38c. per gross, \$4.  
 Serims (for canvassing), 15c.  
 Seats, buggy, pieced rails, \$1.75; solid rails, \$2.50.  
 Shaft-jacks (M. S. & S.'s), light, \$2.60; heavy, \$2.87. a \$3.25.  
 Do. tips, extra plated, per pair, 31c.  
 Silk, curtain, per yard, \$1 a \$2.25.  
 Slat-irons, wrought, per pair, 55c.  
 Slides, ivory, white and black, per doz., \$6; bone, per doz., \$1.50;  
 No. 18, \$1.75 per doz.  
 Speaking tubes, each, \$4 50.  
 Spindles, seat, per 100, \$1 a \$1.25.  
 Spring-bars, carved, per pair, \$1.  
 Springs, best temp. Swedes, per lb, 25c.; black, 18 $\frac{1}{2}$ c.; bright, 20c.;  
 best tempered, 24c.  
 ☞ Two springs for a buggy weigh about 28 lbs. If both 4 plate, 34 to 40 lbs.  
 Spokes, buggy, per set, \$3.60, or about 6c. each for all under  $1\frac{1}{2}$  in.  
 ☞ For extra hickory the charges are 7c. each.  
 Steel, Farist & Co.'s Homogeneous American, per lb, 18c.  
 Do. English Homogeneous, do. 22c.  
 Do. Compound tire, from \$7.50 to \$8, according to thickness.  
 Stump-joints, per dozen, \$1.25 a \$1.50.  
 Tacks, 5c. and upwards per paper.  
 Tassels, holder, per pair, 63c. a \$1; inside, per dozen, \$3; acorn  
 trigger, per dozen, \$1.25 a \$1.50.  
 Terry, per yard, \$7.  
 Top-props, Thos. pat., per set, 35c.; plain, com., 35c.  
 ☞ The patent props, with silver-plated nuts, per set, 87c.  
 Tufts, ball, per gross, 50c.; common worsted, 12c. a 25c.  
 Thread, Marshall & Co.'s Machine, No. 432, \$2.40 per half lb; No.  
 532, \$2.75 do.; No. 632, \$3.50 do.  
 Turpentine, per gallon, \$3.75.  
 Twine, tufting, per ball, 35c.  
 Varnishes (Amer.), crown coach-body, \$5 a \$5.50; hard drying,  
 \$6; nonpareil, \$6.50.  
 Do. English, \$6.25 in gold, or equivalent in currency on the  
 day of purchase.  
 Do. American imitation of English, \$7.  
 Webbing, per piece, 44c.  
 Whiffle-trees, coach, turned, each, 25c.; per dozen, \$2.50.  
 Whiffle-tree spring hooks, \$3 per doz.  
 Whip-sockets, rubber, per dozen, \$7 a \$9; pat. leather, stitches, \$3.  
 Window lifter plates, per dozen, \$1.50.  
 Yokes, pole, each, 75c. to \$1.25.  
 Yoke-tips, 50c. a 75c.

The most remarkable feature in our Prices Current this month is the extraordinary rise in the prices of axles—from 50c. to \$1 on each set. Springs have also advanced 1 and 2 cents per pound. Spokes, 20 cents, with a corresponding rise in a few other goods. With gold up to 159 $\frac{1}{2}$ , we cannot expect to find any relief from the present high prices, particularly in view of the fact that dealers find it extremely difficult to fill their orders at any price. We prefer filling none but cash orders; but, where C. O. D. bills are forwarded with the goods by express, charges for collection must be added, which amount in ordinary cases to from 25c. to \$1, according to distances. All this may be saved by sending us the money with the order.

## TO READERS AND CORRESPONDENTS.

BACK VOLUMES of this work will be sold, in numbers, for \$3; when bound, for \$3.50, to which, if sent by mail, 48 cents must be added to prepay postage; if two or more volumes are called for at one time, they can be had for \$3 each, or will be sent by express, at the purchasers' expense, at the same price. The subscription to the Fifth Volume, now in course of publication, will be (in consequence of the advance in paper and printing) four dollars, IN ADVANCE, for the twelve numbers.

AGENCY.—Our friend Mr. Henry Harper, who is traveling in the West, is authorized to take subscriptions for us, and receipt for moneys paid; and any contract he enters into concerning this Magazine will be honorably carried out by the Publisher. In Canada West, Mr. Robert McKinley, at St. Catharines (dealer in carriage-hardware), will act as our local agent.



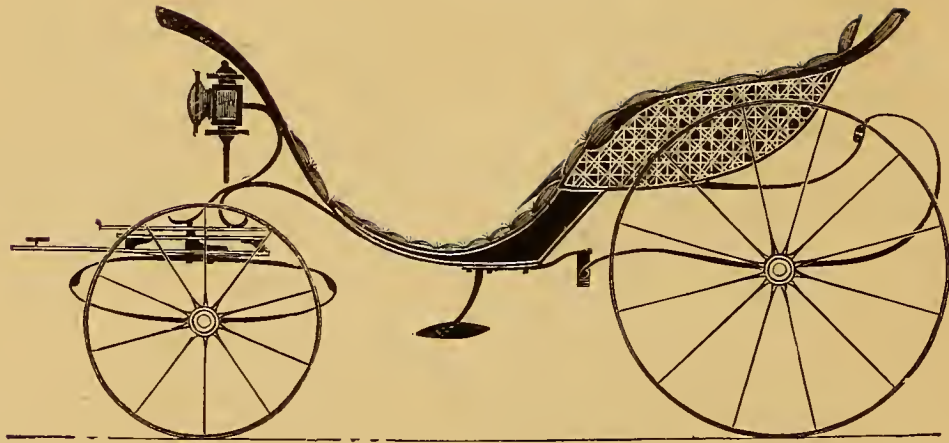

PONY PHAETON.— $\frac{1}{2}$  IN. SCALE.

*Engraved expressly for the New York Coach-maker's Magazine.*

*Explained on page 153.*

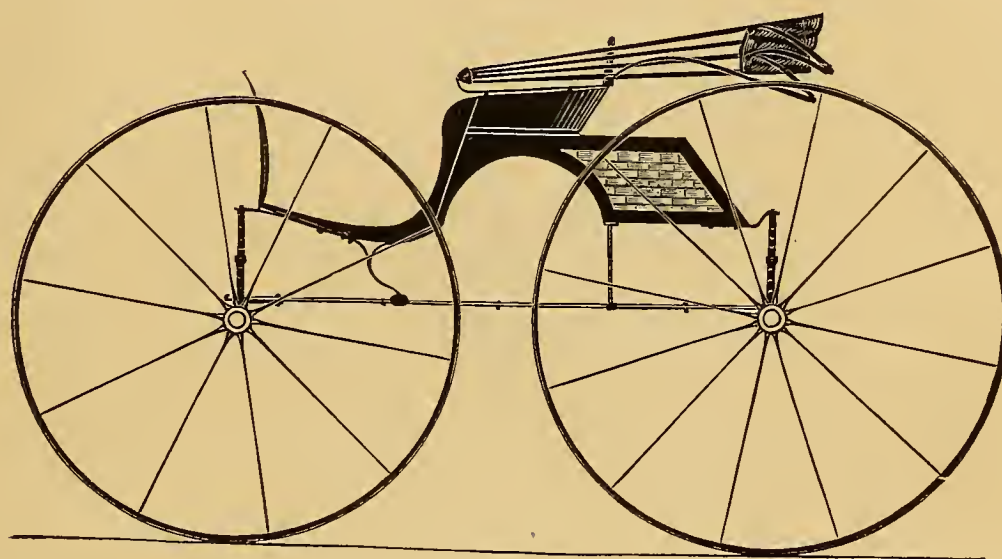

TILBURY BUGGY.— $\frac{1}{2}$  IN. SCALE.

*Designed expressly for the New York Coach-maker's Magazine.*

*Explained on page 153.*





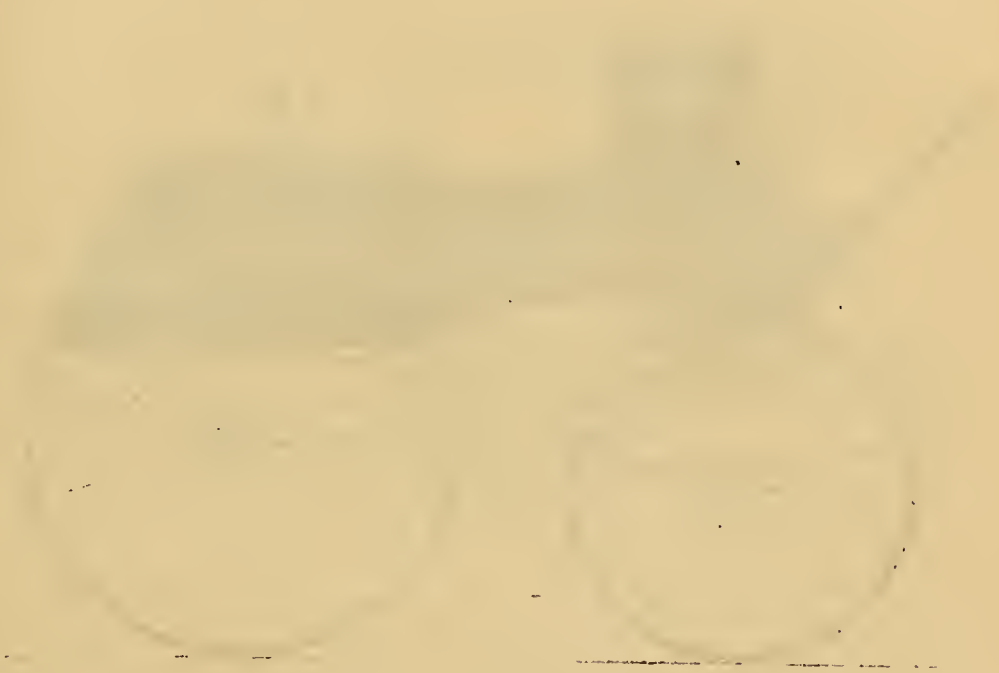

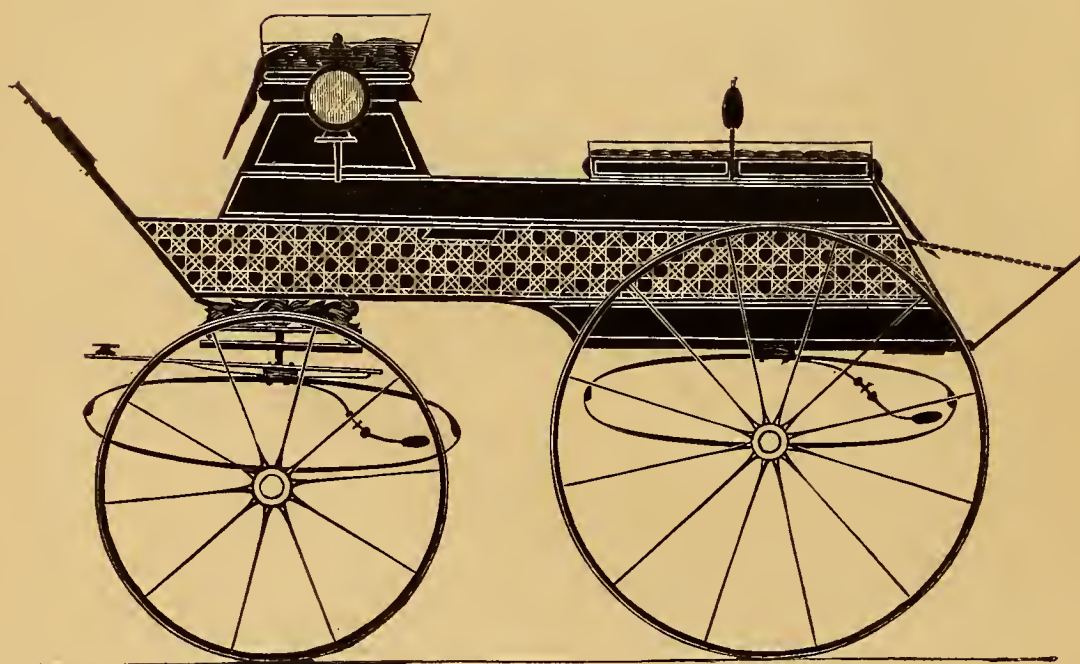

BREAK.— $\frac{1}{2}$  IN. SCALE.

*Engraved expressly for the New York Coach-maker's Magazine.*

*Explained on page 153.*

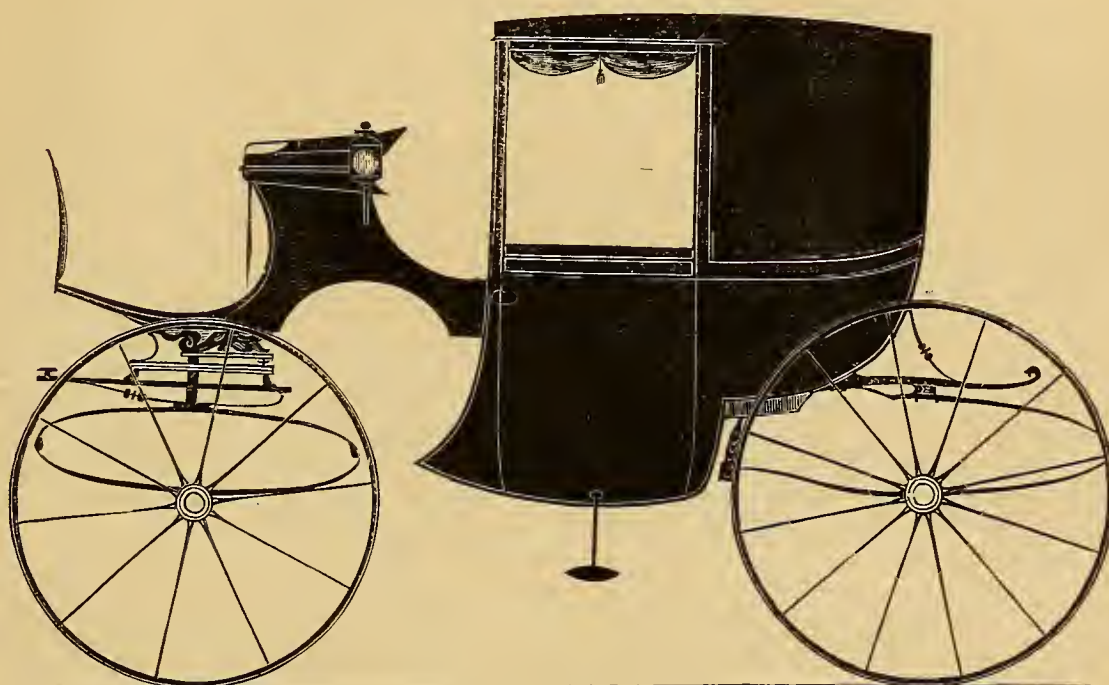

SINGLE-HORSE COUPÉ.— $\frac{1}{2}$  IN. SCALE.

*Designed expressly for the New York Coach-maker's Magazine.*

*Explained on page 153.*





DEVOTED TO THE LITERARY, SOCIAL, AND MECHANICAL INTERESTS OF THE CRAFT.

Vol. V.

NEW YORK, MARCH, 1864.

No. 10.

## Mechanical Literature.

### CARRIAGE WHEELS—THEIR MECHANICAL CONSTRUCTION AND USE CONSIDERED.

BY HENRY HARPER.

(Continued from page 134.)

How much should a wheel be dished? Those who have such horror of the idea of being out of fashion, and of the symmetrical appearance of a dished wheel that they cannot bear the idea of having any innovations made upon their notions of mechanism and taste, may find some consolation when they are told that we have seen some elegant buggies from a factory where the dish in the hind wheels were three-fourths of an inch, and the spokes of the forward wheels stood on the same angle, which made the dish less only in proportion to the size of the wheel. Don't think that you "might as well be out of the world," &c., even if you give the wheels three-fourths of an inch dish. We could not recommend any less, and would prefer more. By some it is supposed that the extra dish given to a wheel when it is new, requires the same proportional dish when the wheel becomes old. Nothing is further from the fact than this supposition. Giving it enough dish when new, and using well-seasoned materials, will preclude, in nine cases out of ten, the necessity of setting the tire a second time in seven or eight years. In that time, a wheel made without any dish when it is new, will require the tire to be reset three or four times, and every time it will have to be made more dishing; the spokes will be bent out of shape and the wheel will be considered as worn out, before the dishing wheel is drawn out of shape. Practical experiments, which I have tried, have proved such to be the case.

The next point to be considered is the convenience that it gives to the construction of the other parts. Just in proportion as the wheel is dished, in exactly the same proportion the rim of the wheel on the upper side should lean out from the body of the wagon, in order to make the bearings on the extremities of the axle equal. If the spokes are drove perpendicular to the axis of the wheel, which makes it straight, the rim of the wheel should stand perpendicular, which makes the distance of the top of the two wheels just as far apart as the tread or track. If the

wheel has three-fourths of an inch dish, the top of the wheel should be leaned one and a half inches out from a perpendicular, which in both wheels will make them three inches wider apart on the top than at the track. This position is of the greatest importance to the durability of the wagon, coach, or, indeed, any kind of wheeled vehicle. It is of the greatest importance that the wheels should be as far from the body as they can, and preserve the right bearings on the axles. It gives more room for the body, throws the mud or sand out from the body of the wagon, and gives more room—in turning the wagon—between the body and the rim of the wheel.

If one wheel is dished half an inch, in order to have the bearings of the axle arm perfect, the top of the wheel must be canted over from the wagon out of perpendicular one inch. If the opposite wheel has three-fourths of an inch dish, it must be canted out of perpendicular from the wagon one and a half inches, making, in all, two and a half inches difference between the distance apart of the track and top of the wheels. The neglect or want of ability to maintain these proportions is the cause, *and the only cause*, of an axle arm and box wearing out, when it has been kept properly lubricated, before the other parts of the wagon. Experience proves this most conclusively to be the case. No one is so entirely ignorant of these facts, but that he has noticed that one arm of an axle often wears out quicker than the other, on the same wagon. This can only be accounted for by supposing the wheels to have a different dish and the axle arms the same pitch; or, the wheels the same dish and the axle arms a different pitch. The former is most generally the cause. Thus it will be seen how easy it is for one who has not studied the principle throughout, to tamper with the most important part of the wagon, to gratify a whim of his own.

The man who has made a straight wheel would not consent to have the smith hang it on the axle so that the rim would stand perpendicular, because that would appear odd and contrary to his taste; yet it is imperatively necessary, in order to make the best wagon that can be made of such wheels, to have them stand perpendicular. The first blunder demands a second, and if the workman is so ignorant of the principles of mechanism that he does not know that they are blunders, he will go on blundering until he has finished his wagon according to his vitiated taste, and which will be a worthless thing in the end.

The effect that straight wheels has upon the draught,

is perhaps a greater defect than in any other respect. We have seen that a wagon wheel is a lever-power. We will now notice one of the impediments against the free working of that lever-power, which is the friction on the axle and axle-box. It can at any time be noticed in machinery that requires perfection in its running parts, that large wheels weighing tons revolve on their axis for months and perhaps years without scarcely any perceptible wear on the axle or box. Every one knows, if that same axle is run one half of an hour without having any lubricating matter applied to it, it will destroy the axle. The question is, how does this lubrication operate to prevent such results? It is a thin coat of oil that is placed between the axle and the axle-box, which prevents two hard metals from coming in contact with each other. This coat of oil can be removed in various ways by the working of the machinery, no matter how freely it is applied, and the very instant the particles of iron come in contact—the machinery being in motion—that instant heat is introduced. The supposed cause of this heat has heretofore been explained in this Magazine, and it will only be necessary to refer to one of the causes of this lubrication being removed.

If we take one of the boxes, or bearings of the axles to this machinery, and turn it so that the axle turns on one corner of the box, the pressure will be so great in proportion to the surface of bearing, that the axle will crowd the oil out from between it and the box; the surface of the two parts of iron will come together and the heating will commence, slowly at first, but it will be absorbed and retained by the adjoining iron, so that the whole box and axle will soon be heated. This is one, and the most common way, in which wagon-axles and axle-boxes are worn out, the same result being brought on by tipping the wheel so that more of the bearings rest on one end of the box than on the other.

In the most perfect running wagons, the angle to the taper of the axle-box, the angle to the dish of the wheel, and the angle that the rim of the wheel stands out from a perpendicular, will be the same. This will require the axle-arm to be perfectly horizontal on the bottom where the bearings come. Consequently, the axle-maker determines the dish that a wheel should have. It may be impossible in every case to make the dish of the wheel exactly correspond with the angle of the taper to the box; certainly it would be to keep it so until the wheel was entirely worn out. If the dish of the wheel lacks of being on the same angle with the taper of the box, the axle on the under side should pitch up from a horizontal line just as much as the dish lacks. If the dish exceeds the taper of the box in its angle, then the axle-arm on the under side should pitch down just to the amount of that excess.

By balancing the weight on the axles in this way, the difficulty about heating or wearing out the axles is entirely removed; and if you will add to it the very plain principle of making the wheels run straight ahead, instead of drawing sideways (as a great many do), the wagon will be as near perfection as it can be made in that respect.

Any uniform principle for making the draught easy and alike on different wagons, has been so imperfectly understood among the craft, that we can hardly find two of its members who will converse on the subject long enough to give their own views, for fear that they will let out a secret that will be of advantage to another. On this subject people may be divided into three classes.

One class really think they have a secret worth keeping; another thinks there is a secret about it somewhere, but as long as they do not know what that secret is, they think it not proper to show their want of knowledge on the subject by talking about it, and their silence indicates as much wisdom as is shown by the first class; another thinks the whole thing is only talk for the sake of humbugging their customers, when, in reality, all that is required is to make the wheels turn around and keep the axle greased. This class sometimes talk about a principle, and sometimes ridicule such a thing. There are but few individuals in business life, who use any kind of a wheeled vehicle but what actually pay a tax, unnecessarily, sooner or later, of from one hundred to one thousand dollars, for the want of definite principles laid down on this subject. To any one who has studied this subject in all its bearings, these *false pretensions* to knowledge on the subject are easily detected, by merely observing the construction of the other parts of the carriage, such as the axle, the dish of the wheel, &c. I have been told, by those who make pretensions to building superior running wagons, that it is inconvenient to always have the tire set on the wheel before the pitch is given to the axle. Had such men have had the most distant idea about a principle to work from, or the necessity of working from a principle, they never would have exposed themselves by showing that they did not know the pitch of the axle depended on the dish of the wheel. Perhaps some of my real friends will recognize, as their own, this conversation, and to them I owe an apology for a duty that was left undone by me. I should have told them what I knew to be the fact, and what a great many others, under the circumstances, would have known to be the fact—that is, the more wagons they built, the greater the injury that they would inflict on community. They may perhaps excuse themselves by saying that because they did not always make their wagons perfect, it was no sign that the next man would do any better. This is not always so. There are men who can determine, with as much mathematical precision, the pitch that an axle should have to agree with the wheel, as they can the length of a board with a rule. These men do not always go unappreciated, as I have noticed. An intelligent and wealthy farmer went twenty miles from his home to one of these, to buy a farm wagon, expecting that he was going to get something better than usual. He was a little "taken back" when he found the price was above the one that he could purchase nearer home for, that looked just as good. The mechanic would not fall in his price, but told the farmer that he might take the wagon home and use it two or three months, and if he did not want it he might return it, and the mechanic would pay him back the price of the wagon, and a reasonable compensation for bringing it back. Of course I had a curiosity to know—as soon as I could—what the farmer thought of his wagon, and I called on him for the purpose. His mind was made up, before he got home, that he would keep the wagon; also, he would send his old wagon, that had been considered nearly worn out, twenty miles to the same mechanic, to have new axles put into it; and this is in a country that is proverbial for a supply of good wagon-makers.

This one thing is absolutely demanded in order to successfully do business: there must be a general reformation about giving wagons an unnecessary amount of draught. This reformation has been sought with a cer-

tain degree of success by hardening the axle and box. That is really an improvement, and *indispensable*; yet, it is entirely useless, unless the condition of making the bearings equal is also observed. It is well known that two hard pieces of iron running together without lubrication will become heated just as soon as soft iron, and when they are heated there is no difference between them in resistance to the wear of friction. Now, is it not plain that if the bearing is thrown on one part of the axle, this lubricating oil will be removed in the way we have explained? It certainly will, and no matter how hard the axle may be made, it will become soft by heat, and worn out, sometimes, in the remarkable short space of one hour, at others in a time varying from one month to five years. In any of these cases the wear is entirely unnecessary, as can be conclusively demonstrated.

A great many fancy carriage-makers are not aware how serious a fault a trifling deviation from the proper position of the wheel makes. If the tread of a wheel is placed one-half of an inch out of the exact position that it should be in, and the axle-box is six inches long, the relative proportion of wear on the two ends of the axle-arm and box will be as 3 to 5, which is twenty-five per cent. more wear on one end of the arm and box, than on the other. Whenever the carriage is moved, this wear will be going on—not in exactly that proportion, because it will increase something in the proportion that reckoning compound interest at twenty-five per cent. would increase the interest. It is as easy to avoid the laws of Nature as it is to avoid this result, without setting the axle properly. But how should the axle-arm be varied, in order to avoid this error? Why, it must have a different pitch—if the wheel is four feet in diameter, the pitch must be varied one-eighth of an inch to the under side of the axle. That eighth determines a very important item. It determines whether the wagon is to be a nuisance, or a valuable machine for the uses that it was constructed for.

We hope no member of the craft will peruse these remarks without reflecting that there is a greater responsibility resting upon him than merely making dollars and cents; and that the field for improvement stretches far beyond his present vision, and which will not by any means fail in interest to those who search therein for truths which can be usefully applied.

(To be continued.)

#### “AN ADVERTISEMENT ABOUT THE PATENT FOR EASIE COACHES.”

UNDER this heading, about the middle of the last century, appeared the following: “All the Nobility and Gentry [in England] may have the carriages of their Coaches made new, or the old ones altered after this new Invention, at reasonable Rates; and Hackney and stage coachmen may have Licences from the Patentee, Mr. *John Green*, and Mr. *William Dockura* his partner, at the rate of 12*d.* per week, to drive the Roads and streets, some of which having this week begun, and may be known from the common Coaches by the words Patent Coaches being over both doors in carved letters. These Coaches are so hung as to render them easier for the Passenger and less labor to the Horses—the Gentleman's Coaches turning in narrow Streets and Lanes in as little or less room than any *French* carriage with Crane-neck and not one third part of the charge. The manner of Coachman's sitting is

more convenient, and the motion like that of a Sedan, being free from that tossing and jolting to which other Coaches are liable over rough and broken Roads, Pavements or Kennels. These great conveniences (besides others) are Invitations sufficient for all Persons (that love their own ease and would save their horses' draught), to use these sort of Carriages and no other, since these Coaches need no alteration. All persons may be further informed at Mr. *Green's* house, in Carteret Street, by the cock-pit Royal in Westminster, and at Mr. *Dockura's* house in *Little Saint Helen's* in *Bishopsgate Street*, who hopes his Partner and he shall fare better by this Invention than he did by setting up that of the Penny Post.” What form this spring took it is very difficult to determine; probably it was similar to those applied to Figure 22, on page 91 of our Fourth Volume.

### POMPEIAN ROADS AND CARRIAGES.

BY THE EDITOR.

(Concluded from page 132.)

WHETHER the illustrations we give in this chapter are the representations of the carriage-builder's ingenuity, or merely the creations of the painter's fancy—in either case, they are of great interest to every lover of his trade at the present day. They are copies of exhumed frescoes from Pompeii, and serve to show the state of art, centuries past. The first, Figure 2, exhibits a swan-shaped



Fig. 2.

car, hung upon two wheels, and Love in the act of driving the two mules harnessed thereto. As a matter of taste, the employment of such animals in this instance is open to criticism, unless, as we suspect, the artist, out of compliment to a *stubborn* mate, or as a sort of retaliation against the winged deity for leading him into domestic trouble, employed his leisure time in producing it. At any rate, there is evidently much meaning in thus yoking contrary animals to the car of the fickle god. An inspection of the wheel carries the mind back to that remote period when art was in its infancy, and wheels were made from solid logs. The only redeeming feature in this case is, the wheel appears to be furnished with a metal rim, bolted to a corresponding one on the inside, to strengthen it.

The second example, Figure 3, was taken from the walls of the tablium of the peristyle of the Dioscuri, the original of which was painted on a yellow ground. In this instance we have presented a rudely formed chariot,

drawn by goats, with the modern detail of traces, harness, &c., entirely omitted, a common neglect in many of the antique figures bequeathed us. The chariot is deficient in



Fig. 3.

many respects. As others have remarked, there is an absence of elegance in design—the angle supplying the place of those graceful curves which characterized the Grecian and some other chariots of an earlier date. This, however, may be more the fault of the artist than of the Pompeian artisans.

The *Basterna*, or litter, seems to have been known to the Romans, but not quite in the same sense we entertain of them. Among them they were a close kind of chair, drawn by beasts only. Cicero says that Veres made use of one superbly decorated, having cushions stuffed with roses. This is supposed to have had a seat in the center, in which the occupant sat upright. These are supposed to have been in use in the decline of the Republic.

The odometer, or road measurer, seems to have formed, sometimes, a part of the fixtures of a Roman carriage. Vitruvius, in describing a carriage, says (Book X.), “from the side of the carriage and connected with the interior machinery, a finger or rod jutted out, which at every revolution of the wheel came in contact with a projection against which it tapped, by which a sound was made, and the hand was moved forward on the indicator. In this manner the number of paces which had been accomplished was shown, and the riders knew exactly how much of their journey had been performed.”

If we add to the foregoing the productions of the Poets, the ancients had various costly vehicles, with wheels of brass and gold. No doubt they had veritable wagons, carts, &c., which research has hitherto been unable to find. Pliny relates that an artist of his day, Myrmecides, made and exhibited a carriage and horses of brass, ivory and marble, the whole no larger than a fly. An energetic people, such as the Romans were, no doubt had a very great variety of carriages, many of which, not possessing the character of public vehicles, have been neglected by both the writers of poetry and history, and consequently their name as well as form are irrecoverably lost. Speculations might serve to confuse the mind of the sober reader, but will give very little satisfaction to the student of history.

**FASHIONS IN BUGGIES.**—There is nothing particularly new in the fashions of Buggies, this spring. The standard appears to be the square-body, with sides from five to ten inches deep, panned boots, and close seats. Prices varying from \$225 to \$265.

## EFFECTS OF WHEEL-CARRIAGES ON ROADS AND HORSES.

### CHAPTER V.

1. Friction does not increase with the increase of the rubbing surfaces: proved; consequently not with an increase of the number of axles. Practice of the Author. 2. Practical use of many wheels. 3. Proposed remedy for the old defect in the construction of Six-wheel and Eight-wheel Carriages, illustrated by engravings. 4. Causes why the Six-wheel and Eight-wheel Coaches were discontinued. 5. Suggestions for obviating these causes. 6. Matthews' Patent Coach.

1. HERE it may be proper for me to meet an objection that we frequently hear advanced against four-wheeled carriages, viz., that having twice as many axles as a two-wheel carriage, they have *proportionably* more friction. The position stands thus: that friction increases as the rubbing-surfaces increase, without regard to the weight of the sliding-bodies. Let a man take a common brick, nine inches long, four-and-a-half inches wide, and two and a quarter inches thick; let him draw it along a board, by means of a line, over a single pulley at one end of the board, and a weight falling perpendicularly at the end of the chord. First, let him draw it along upon its broad side: he will find that it will require a certain weight to draw it along the board. Then let him draw it along upon its edge. He ought, upon the above supposition, to find exactly *half* the weight sufficient, because the brick is now sliding upon exactly one-half the surface. Then let him draw it along upon one of its ends, the brick standing upright. He ought now to find one-quarter of the weight he first used sufficiently powerful, because the brick now slides upon exactly one-fourth of the extent of surface that it did in the first instance; but, instead of these results, he will find that the brick will require precisely the same weight to draw it along in each of these experiments, provided the brick be alike on both sides, not presenting any sharp points to stick in the board on one side more than on another. Therefore, the friction upon any number of wheels and axles, carrying the same weight in the whole, is exactly the same.

I have a light wagon, about seventeen hundred weight,\* with turned axles, and brass boxes bored to fit them, which requires about an ounce of oil at a time—more would be wasted. With this wagon, two horses constantly fetch forty-eight bushels of coals from the pit, at least two tons; they also fetch as much manure as the wagon will hold, frequently more than two tons—each several miles on hilly roads.

I also use olive-oil for my carts, dung-carts! Perhaps my wagon, two carts, and a gig, may consume from two to three pints of oil in the course of a year, at fifteenpence a pint—not one shilling apiece for each carriage. I am satisfied that my two horses would travel with two tons nett weight on my wagon, stage for stage with any road wagon in England in which the horses draw on an average not more than eleven or twelve hundred weight each, nett weight. Nay, my carter says he is certain that these two horses could take forty-eight bushels of coals (two tons) to London, one hundred and twenty miles, in four days, without an injury or extraordinary fatigue. I mention this to show how completely the horses are above their work. Now, although these horses might possibly

\*Don't smile, reader; because this was written forty years ago, and in England. A light wagon with us would weigh about one hundred and fifty pounds; but, then, an Englishman would have nothing to do with *such* suicidal vehicles. —Ed.



draw this load in a cart, it would, I think, never enter into the head of a reasonable man that they could go thirty miles a day with it for four days together. There must, then, be an intrinsic difference in favor of the wagon, whereby the horses have such high command over their work, which is simply this: whereas with a cart of the same weight, with wheels four feet eight inches, the horses must make an exertion equal to 1609 pounds, to draw one wheel over an obstruction three inches high; they have, in the case of the wagon the fore-wheels of which are four feet high and the hind-wheels five feet high, to make an exertion equal only to 883 pounds to draw one of the fore-wheels, and an exertion equal only to 773 pounds to draw one of the hind-wheels over such an obstruction. And if the wheels were increased to six or eight, I suppose the horses would draw the same weight with nearly a proportional increase of facility. And the difference, as regards the roads, would be such as I have before explained.

Another thing is also obvious, viz., that if these two horses drew this load in two single horse-carts, each of half the weight of the wagon, each horse would have exactly the same exertion to make at any obstruction, as though the two horses drew the whole load in one cart. Hence it is evident that the principle of division is equally important, whether the load be great or small, or whether it be drawn by a number of horses, or only by one.

2. But, that axle-friction, when the parts are oiled, is very small, is proved by the enormous weights of coals and iron-ore drawn by one horse on iron-rails, or tram-roads, in a series of small four-wheel carriages, one behind another, at least six in number, carrying a gross weight of several tons. Here, although the horse has to overcome the friction of twenty-four axles, yet, the major obstructions being in a great degree removed, he is enabled to draw these heavy weights.

3. It would be easy to construct six-wheel and eight-wheel carriages in such a manner that, when turning corners, all the axles shall be so many excentric radii; or, in plain words, in the case of an eight-wheel carriage, when the fore-axle shall lock two degrees, the second axle shall lock two degrees, the third axle shall lock one degree, and the hindermost axle shall be fixed.

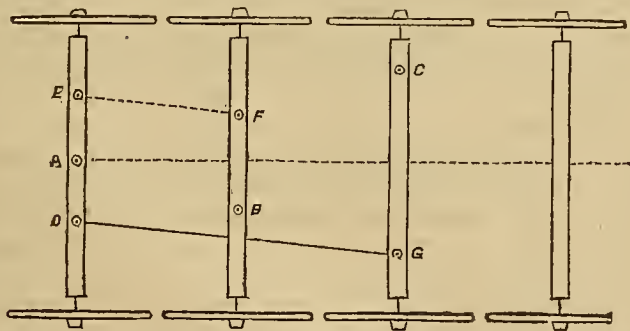

The above figure is intended to represent the machinery necessary to effect the locking of the wheels of an eight-wheel carriage, as above described. A is the perch-bolt of the fore-axle; B the perch-bolt of the second axle; C the perch-bolt of the third axle. E F is an iron brace, with a bolt and an eye at each end of it, to communicate motion from the fore-axle to the second axle; D G is a similar brace, to communicate motion from the fore-axle to the third axle. As the second axle is to move two degrees when the fore-axle moves three degrees, it will be necessary that the distance from B to F be to the distanc

from A to E as three is to two, or half as much again; and as the third axle is to move one degree when the fore-axle moves three degrees, it will be necessary that the distance from G to C be to the distance from A to D as three is to one, or three times as much. Now, as it will be necessary, for the steadiness and well-working of this machinery, that the braces be set as wide apart as possible, the distance from the perch-bolt to the brace in the third axle must be settled, which I have taken at forty inches; this will give  $13\frac{1}{3}$  inches for the distance from A to D; and as it is necessary, for the even draught of the carriage, that the brace-bolt E be exactly the same distance from the fore perch-bolt as the brace-bolt D, the distance from A to E will also be  $13\frac{1}{3}$  inches; and the distance from B to F, in the second axle, will of course be  $13\frac{1}{3}$  inches and half that quantity, or 20 inches. The bolts must be placed exactly at equal distances from the center-line of the carriage, in each axle respectively, which will cause the second and third axles to act with equal force against each other, whereby the draught on the fore-axle will be equal.

For a six-wheel carriage the same machinery would answer very well, omitting the hinder-pair of wheels. It would, however, be better if it could be so managed as for the third or hinder axle to be fixed, and for the first and second axles only to move, as thereby the carriage would turn in less compass. It may be done, but not by any plan that I am aware of, without causing an unequal draught on the fore-axle; but in this case there would be no other brace to act against it.

Or, for a six-wheel carriage, the middle axle might be fixed, and a *contrary motion* might be communicated from the fore-axle to the hinder-axle by means of two rods or braces, one passing from the near side of the fore-axle to the hinder-axle, by means of two rods or braces, one passing from the near side of the fore-axle to the off side of the hinder-axle, the other passing from the off side of the fore-axle to the near side of the hinder-axle, crossing each other in a mortise in the middle of the middle-axle. Each of these rods must have a length of chain at each end of it, to work on two semi-circles, to be fixed on the *insides* of the fore and hinder-axles, which should not be of less diameter than three feet. Hence the hind-wheels would in all cases follow in the same track as the fore-wheels, and the carriage would turn in a very small compass; but I think it would be heavy and noisy, and would be very liable to get out of order.

Or, for a six-wheel carriage, if the braces in the figure were brought to the distance of only eight inches on each side of the perch-bolt of the fore-axle; and the perch-bolt and brace in the second axle were brought to a distance of  $13\frac{1}{3}$  inches, which bears a proportion to eight, as five is to three; then the fore-axle locked five degrees, the second axle would lock three degrees; and as the space from C to G in the third or hindermost axle is forty inches, and the distance from A to D in the fore-axle would be eight inches, they would bear a proportion to each other, as five is to one: consequently, when the fore-axle locked five degrees, the third or hinder-axle would lock one degree; whereby the middle axle would always form equal angles with the other two axles;—that is to say, the fore-axle would lock as much more than the second axle, as the second axle would lock more than the third axle; consequently, the three axles would always form concentric radii, or nearly so, and the carriage would turn in very

little compass, as the locking of the third or hinder-axle would be very trifling.

As in this latter application of the machinery the two bolts in the middle axle would be each within seven inches of the center-line of the carriage, attention must necessarily be paid to the strength of the middle-axle, near these bolts. It is scarcely needful to observe that, in all these dimensions, the center of each bolt is to be understood.

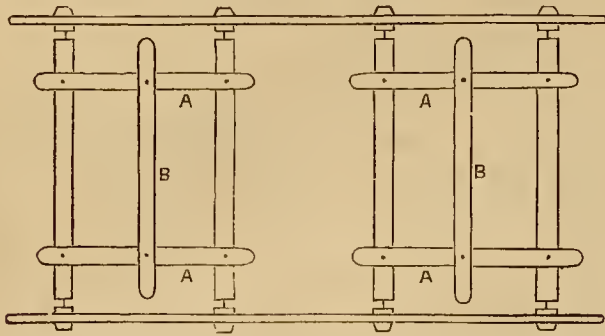

The above figure is intended to represent the framework necessary for producing an equal bearing of the load on each wheel of an eight-wheel carriage. A A A A are four pieces of wood, bearing on the first and second, and on the third and fourth axles; B B are two pieces, bearing again on these. These are what I believe the workmen call the pillow-blocks, on which the bed of the wagon or the springs of a coach are fixed.

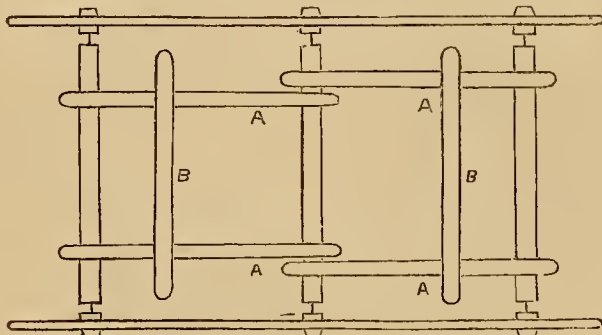

The above figure is intended to represent the framework of a six-wheel carriage, whereby each wheel would bear exactly one-sixth part of the load. On which I need only observe that the two pillow-blocks marked B must be placed one-third of the distance from the fore and hind axles, respectively, to the middle-axle; consequently the fore-axle would take two-thirds of the weight of the fore-end of the body, and the middle-axle would take one-third; and the same of the hinder part; therefore, each axle would bear one-third of the whole load.

4. Should it ever, hereafter, be deemed expedient to have recourse to six-wheel and eight-wheel coaches, it must be kept in mind that the principle I have insisted on is, that an eight-wheel carriage would cause less labor to the horses, and less injury to the roads, than one of six-wheels, each carrying the same gross weight;—that one of six-wheels would cause less labor to the horses, and less injury to the roads, than one of four wheels, all carrying the same gross weight.

But the six-wheel and eight-wheel carriages being favorable for a long body, the passengers sitting sideways, this was the form, I believe, always used for these carriages, some years ago, which affords several causes for their getting out of use. One I have before given, in the

case of the Bath and Bristol coaches; another was the circumstance of the passengers sitting sideways, which was very unpleasant, particularly by night; another was that their bodies, which were ten or twelve feet long, afforded the proprietors and their servants opportunities of carrying enormous loads of luggage on the top, besides a crowd of passengers within and without, with which the poor horses were expected to travel as fast as with lighter coaches. Of course it is no wonder if these long coaches, so unmercifully loaded, unfairly acquired the reputation of *killing the horses*. Passengers were disgusted at being confined, during a dark night, with a large promiscuous company, the side-motion at the same time being very unpleasant, and there being nothing to lean against, except for those who could catch the ends of the long seats. Under all these circumstances, it is no wonder that these coaches disappeared.

5. I see no reason why a coach-body of nearly the common construction might not be made, wide enough to carry four passengers on one seat, with a stuffed partition in the middle, from the seat to the top of the coach, a foot or fifteen inches wide; which would give every one a *corner*. A coach thus formed need not exceed five feet six inches in width, provided it were as wide at the backs of the seats as across from door to door; or, if this were inconvenient, a carriage might consist of one common six-inch inside body, with another body attached for passengers at an inferior price, with two seats, to carry four persons each; this body to have a fixed covering, or *head*, and curtains to draw at pleasure, as is the case with two or three public coaches that travel out of Bristol. This would make fourteen passengers, besides one on the box, with the coachman—in all, sixteen persons; enough, surely, with luggage, for four horses to draw eight or nine miles an hour!

Luggage might either be stowed below; or in a chamber between the two bodies, or under the coachman. But on the top should be put neither passengers nor luggage.

It is scarcely in human nature to resist temptations of gain; it is therefore necessary for coach-masters to *limit the accommodations* of their carriages to such a number of passengers as their horses can properly draw; otherwise their servants will take up every twelve-penny passenger that offers on the road, and, let the construction of their vehicles be what it may, they will find them **KILL-HORSE COACHES**.

6. Perhaps, by the above suggestions, I may be thought to be proposing an infringement on Matthews' Patent. I have seen his coaches, and have read his specification, and I cannot see clearly on what ground this Patent stands. It contains no *new principle*. Stowing luggage underfoot is of very old date. Milton's Patent was precisely this. And I have myself seen traveling-carriages, many years ago, with chambers for luggage under the floor of the carriage. Nor is there anything new in people riding back to back, the seats being placed lengthwise; what is called the Outside Irish Car is so constructed. I have also seen machines of this form for conveying military. I have also seen outside-seats, back to back, placed crosswise; the double seat forming one luggage-box. We have seen two close bodies on the same wheels, one close and one open on the same wheels,—others with seats behind and seats before. And this coach appears to me to differ from others merely in the modification of the seats, but without anything, in princi-

ple, that has a claim to novelty. It should also be known that to every Patent is attached the following condition, on the part of the Patentee, viz.: "That he is the first and sole inventor, and that the same hath never been used, nor practiced, by any other person or persons whomsoever." Now, most of the particulars specified in Matthews' Patent is founded, have been used and practiced before: therefore, I conceive that, so far, his Patent is unavailing.

## Home Circle.

### WELCOME TO THE BLUE-BIRD.

BY J. T. ELLETON.

WELCOME, sweet bird of early spring,  
Thou fairy minstrel, clad in blue—  
I am rejoiced to hear thee sing,  
But fear some harm may come to you.

For see, the snow is falling fast,  
And every winged songster fled—  
Thy friend am I, fear not the blast,  
Thou shalt have shelter—shall be fed.

But tell me why it was you came  
So soon to leave thy Southern home;  
And why you plumed your wings in flight,  
Towards this semi-frigid zone?

But thou art dumb to all I ask,  
Yet could'st thou tell thy simple tale,  
I ween it were the cannon's roar  
That drove thee to our peaceful vale!

Perhaps it was that you beheld  
What caused thy feeble frame to shiver—  
The blood of youth and beauty spilled—  
This drove thee o'er Potomac River.

If such the trials thou hast seen,  
Doubtless thy breast has throbb'd with fear;  
Rejoice, I say, then—sing with me—  
Let's both rejoice that we are here.

O stay with us, then, lovely bird,  
Return not south of Dixie's line;  
For storms will not forever last;  
The sun again will surely shine.

Come, let thy wearied frame recline,  
And shrink thee not with hunger dread,  
But rest thee in this grove of pine,  
Come, rest awhile, thou shalt be fed!

AUBURN, N. Y.

### THE DESERTER;

A STORY OF THE MEXICAN WAR.\*

BY JAMES SCOTT.

THE camp on the beach at Vera Cruz will always be remembered by those who served under General Scott in Mexico, for, what with sleeping on sand, eating sand, and

\* The MS. of this article has been in our hands some time, but we have found it extremely difficult to make room for it. It will be read with interest as coming from the pen of an old correspondent—who writes whereof he knows—in these times, when our whole national horizon is darkened with the clouds of war.—ED.

being eaten in turn by sand-flies—to say nothing of yellow fever and doing duty on "the mule-yard guard"—it was the most execrable camping ground in the whole country, not even excepting that on the salt marsh near Chalco. The day on which orders were issued to prepare for the march inland was one of jubilation among the denizens of the tent-city; and, spite of burning sun and close, pestilential atmosphere, the most reckless merriment prevailed among the troops. Even in our regiment of regulars, there was an obvious relaxation from the iron discipline usually enforced, and there was a very palpable odor of whisky floating around among the tents, that would have bred a precious row at any other time.

The foreign element in the ranks of the American army consists principally of Irish and Germans, and in the Company to which I was attached there had sprung up, from some cause, a bitter and irrepressible feud between those two nationalities, the result of which was a constant succession of petty squabbles and clannish fights. It was in vain that the most active of the partisans were promptly and severely punished after every outbreak; indeed, punishment seemed to increase rather than diminish the rancorous breach between them; for the Irish, when punished for fighting, couldn't see any "rayson" in the operation, and considered themselves martyrs in a good cause; while the Germans were wont to argue that the other side were invariably the aggressors. The time of general license, brought on by the busy preparations to advance, afforded too good an opportunity for a skirmish between the opposing parties to be lost, and the usual prelude of sharp words and fierce looks soon commenced; nor was the overt act long delayed. A Dutchman, who was lighting his meerscham at the cook's fire, was incontinently, and with malice prepense, kicked over into the aforesaid fire by a malignant member of the Pat-faction, and then came the tug of war. Both parties mustered all their strength, and the conflict was truly terrible. It was well that none of the combatants used their bayonets, for, if they had, many lives must have been lost in the mad tempest of passion that swayed them. Carl Brenner, a man of great muscular power and fiery, vindictive temper, was the acknowledged champion of the Germans, and on that day he entered into the fray with a spirit that animated his comrades to a more than ordinary display of pugnacity; in fact, the Hibernians were, for once, getting the worst of it, when one of them, rendered furious by a stinging "uppercut" on the smeller from the sledge-hammer fist of Carl, seized a tent-pole that lay near, and brought it so forcibly in contact with the skull of the Teutonic leader, that he fell senseless to the earth. Hostilities were instantly suspended, for both sides supposed him dead, and the Irish beat a hasty retreat to the tents, just in time to escape a strong party of the guard, headed by the "officer of the day," who had hastened to the scene to quell the disturbance. The prostrate Carl was raised by his comrades, and any fears they entertained as to his death were speedily dispelled by that individual sending forth a volley of oaths fearful enough to sink a continent. Ireland and the Irish were condemned separately, collectively, and miscellaneously. The army, Mexico, the United States, and the inhabitants thereof, were consigned to everlasting brimstone; and lastly, the infuriated *Ditcher* vowed the most summary vengeance on "der mans wot strikes me on mine cophf mit der dent-bole." His vocif-

erations were cut short by the officer, who thought the man intoxicated, ordering the guard to arrest him. Now the German, who thought that he had already been most foully abused, protested in his unintelligible English against the further indignity implied in the order for his arrest, and attempted to inform the lieutenant as to the part he, the Dutchman, had played in the row; but seeing that his jargon was not fully comprehended, he undertook to make his story clear by a sort of pantomime, made up of the wildest and most grotesque gesticulations, that only served to confirm the opinion that he was drunk; and the patience of the officer, which had been fast giving way, reached the culminating point, and, turning to the sergeant of the guard, he said, sternly:

"Seize that drunken brute, and duck him until he cools off; then confine him in the guard-tent!"

This was too much for Carl to bear; and springing forward, he caught the officer by the arm, while in a voice hoarse and tremulous with excitement, he cried:

"Dundre vitter! eich hob done noting for make me in der gart haus. Whas for you not sends der red mouf Irishmans dare? Dey prakes mine coff mit der glub, ant makes me down in der sant so hart, like mad. Here it ish; here is der bole dey strikes me mit—look!" and he picked up the club that had been used so effectively on his own cranium.

He had worked himself into a perfect frenzy as he spoke, and in showing it to the lieutenant, the excited Teuton inadvertently brandished the weapon under the very nose of that officer, who, not having understood half of what had been said, construed the action into a hostile demonstration, and snatching his saber from the scabbard, he dealt the man a sharp blow on the side of the head with the flat of the blade. There is a certain point in the temper of every man, to drive him beyond which is to render him desperate; this point had been reached in the case of Carl, and with a howl of rage he felled the officer to the earth; the sergeant who rushed to the rescue shared the same fate. Half a dozen bayonets were leveled at the madman's breast, but with a sweep of the pole he scattered them, and ran like a deer for the ridge of sand-hills that flanked the camp on a line with the coast. Hundreds of men were after him in an instant, but he gained steadily on them all. "Fire on him!" was shouted by a score of officers of all grades, from a colonel down to a lance-corporal; and musket, rifle, and pistol-balls raised little whiffs of sand in front, behind, and on both sides of the fugitive, but still he flew on with greyhound speed. A mounted "orderly" tried to ride him down; the fatal tent-pole was shivered over the horse's head, and the animal, rearing madly, threw his rider—then snorting with fright, tore down through the pursuing crowd, scattering them like withered leaves before a gale of wind. The flying desperado topped the ridge, looked back for a moment over his shoulder, and disappeared. A squad of dragoons were seen approaching at a hard gallop, to join in the pursuit; they, too, reached the summit of the ridge and were shut out from view. Those on foot withdrew from the chase and returned to camp. The drums beat for parade, and all sought the tents to don their accoutrements and speculate on the probable fate of Carl Brenner—would it be hanging, or shooting? for none doubted that he would be captured by the Cavalry.

Parade was over, supper was disposed of, and darkness was fast creeping in from the sea, when the tramp of

horses' feet announced the return of the pursuing party. All rushed to get a glimpse of the prisoner. There were big flecks of foam on the reeking steeds, and spur-drawn clots of blood on their flanks; the men were hot, dusty, and tired; the face of the commander was clouded with wrath and vexation, but—there was no prisoner! He had managed to reach the dense expanse of chapparel that stretches away inland towards the base of Orizaba, and there he eluded all efforts to capture him. The affair produced much feeling in camp. Those in the ranks, to a man, admired the daring and successful exploit, and the officers were deeply chagrined that so bold an act of insubordination should go unpunished. Nothing else was talked of that night; but the stirring sound of the "General" (a call to strike tents and march) that aroused us at daybreak next morning, and the near prospect of meeting the enemy, drove the occurrence from our minds, only to be recalled when we happened to see a certain lieutenant with a bandaged head, or when some of the Germans mentioned the name of Carl Brenner.

Several months had passed—months of fatigue, privation, and hard knocks, when our company was detached to strengthen the escort of a provision train bound for Jalapa. We were to accompany it until a point on the route said to be occupied by a force of Guerillas, was passed, and then, if possible, keep the road open until it returned. The place in question was a deep, but narrow gorge in the mountains; the road wound through it, and fifty brave men, posted up on the cliffs that walled it in, might easily have blocked the passage of a thousand men. On approaching this point, a strong detachment, including our company, was sent in advance to feel the way, as it were; and, sure enough, the place *was* occupied by the enemy, and we immediately set about dislodging them. They were posted in a strong position high up among the rocks, and the ugly muzzle of a piece of artillery was visible, gaping menacingly down on the road. After a short consultation among the officers, it was determined that half our force should scale the precipice and assail them in flank and rear, while the remainder at a given signal were to attack in front. We of the storming party unslung our knapsacks and threw them in a pile on the roadside; most of the men took off their coats, many their hats, and our orderly-sergeant, seeing a big fellow rolling up his shirt-sleeves, jokingly rolled his own trousers-legs up to his knees. Nor could the captain, martinet as he was, object; for he himself was coatless, aye, and beltless—for it would have been difficult to climb, with a scabbard dangling at his heels. The command was given to advance, and away we went, up the roughest mountain-side it has ever been my lot to climb. Our movements were soon discovered by the foe, and a brisk fire was opened on us, chipping the rocks in every direction and wounding several of the men, but not for one instant retarding our ascent. We at length reached the plateau on which the Mexicans stood, and found ourselves within a hundred yards of a rough barricade they had thrown up to protect their flanks. Sheltered from the fire by crouching behind rocks and bushes, we paused to take breath and wait for stragglers. The captain, in order to reconnoitre their position, rashly mounted a huge piece of granite, from the summit of which he could overlook their defences, and had just straightened himself up and thrown his eyes forward, when a man suddenly appeared on the barricade, raised a carbine, and fired—our commander

fell back from the rock with a heavy thud!—he was dead when we raised him—shot through the brain. With a yell of exultation, the figure on the barricade disappeared, but not until fifty pairs of keen eyes had recognized him—it was Carl Brenner, the deserter! The cry for vengeance that burst from the men, and surged in reverberating echoes from crag to crag, was terrific. "Forward!" shouted our first lieutenant, springing from his cover and shaking his sabre in fury—"charge!" The stoutest fort in all Mexico could not have withstood that wild, headlong rush, and in ten minutes there were thirty lifeless Mexican bodies strewn among the rocks, and a pitiless shower of musket balls was rained on a disordered mass of fugitives who were rushing madly down the rugged slope, leaving bloody tracks and bullet-stricken wretches writhing in death, to mark their course. The renegade was not among the dead, and our victory was thus shorn of half its value; but his life was not worth much, if fate ever threw him into our hands, for hearts that had sympathized with the man driven by desperation to commit a breach of discipline that outlawed him, now execrated the murderer, and vowed death on sight as his portion!

(To be concluded next month.)

## Pen Illustrations of the Drafts.

### BREAK.

Illustrated on Plate XXXVI.

THIS design is of French origin, and exhibits, in the superlative degree, that "quiet good taste" so desirable in vehicles of the kind. As a sporting carriage for a large party, it cannot well be exceeded, combining, as it does, the dog-cart with the pleasure vehicle. The caned work to this body very happily relieves it from that clumsy appearance generally imparted to deep-sided work, and supplies a fine airy compartment to the dogs. The very high front seat and box furnishes ample room for the stowage of ammunition—that for the stomach included—and the game. We trust it will find favor with our readers.

### SINGLE-HORSE COUPÉ.

Illustrated on Plate XXXVII.

It is with no ordinary degree of satisfaction that we present this draft to our readers. The front, although it will not be seen in the drawing, is intended to be a contracted one, with three front windows, the middle one sliding. The doors are also contracted at the bottom, allowing room for the rocker-plates. Wheels, 3 ft. 4 in. and 3 ft. 6 in.; hubs, 5 x 7½ in.; spokes, 1¼; felloes, 1¼ x 1¼; springs: front elliptic, 3 ft. 7 in. long, 1½ No. 3, steel, set 9 in. apart; and back (platform side) 1 ft. 10 in. each way, measuring from the center bolt to the ends; number and width of the steel, the same as the front springs. We merely add here that, where concealed hinges are used, the middle post should be—for the up-

per hinge—at least 2 x 2½ in., and somewhat larger, of course, below. The modern conveniences are—a bell to call the attention of, and a speaking-tube to communicate with, the driver, and a glass inside for arranging the toilet; card cases, &c. For the rocker-plate, see page 121 of this volume.

### PONY PHAETON.

Illustrated on Plate XXXVIII.

THIS kind of carriage was quite popular with our Canadian friends last summer, and we also saw a sprinkling of them in the streets of New York. They make a very convenient and respectable turn-out for fair weather, at a moderate cost. The reader is requested to notice the peculiarly easy sweeps in the side-quarter, and the reflector-lamp—a great improvement over all others for night travel, as by their use light can be thrown upon the road a great distance. The scroll spring adopted in this design is very old; but we see that our Patent Office, with its accustomed *liberality*, has granted a patent for the same thing, in principle, to an *adventurer* known to our readers either by report or a *costly* personal call. We evidently need a reform in the mode in which letters patent are bestowed in this country.

### TILBURY BUGGY.

Illustrated on Plate XXXIX.

FOR a medium weight business vehicle this design will answer a good purpose, it being calculated for short turning, without resorting to a perch-coupling, which, in its operation, is liable to do a little more than is desirable—*turning entirely over*. The drawing is from a design originating in this office, and is so well explained in itself that we deem elaborate details uncalled for.

## Sparks from the Anvil.

### MALLEABLE CAST-IRON.

To many the production of malleable cast-iron is a profound secret; and it cannot be denied that there are processes now practiced among many makers of this material known only to themselves. Perhaps it may not be generally known that all malleable cast-iron is simply cast-iron partially decarbonized by exposure either to metallic oxyds or to other substances having an affinity, equal or nearly so, to that of oxygen for the carbon contained in iron.

To Samuel Lucas, of Sheffield, England, is accredited the invention of malleable iron. His patent was obtained in 1804. But from a communication read by M. Brüll, before *La Société des Ingénieurs Civils*, at Paris, it appears that the illustrious Reaumur, as early as 1722, having the curiosity to learn the possible truth of the workman's tradition of a lost art of producing sharp and durable chisels from cast-iron, undertook a series of experiments which completely demonstrated the probable truth of this tradition, inasmuch as he actually produced

iron which was fusible and malleable. An English writer, in a late number of *The Engineer*, says he one day picked up an old annealed cast-iron wheel-skid from a lot of scraps in a founder's yard; and having requested a smith to break off a piece, which was done with difficulty, and after heating it to a cherry red, the same as that for copper, he drew it into a chisel. This took the color of steel, when cooling from a like heat, and was hardened and ground, and found to chip or cut wrought-iron tolerably well; and for many purposes in wood-work it answered very well.

M. Brüll states that Reaumur, after many experiments, adopted a mixture of chalk and bone-lime, with charcoal. The castings of white iron were heated in close crucibles, along with mixtures of this sort, until they were sufficiently decarbonized. As now made in England, malleable iron is produced by heating the castings, slowly to a red heat, while confined in closely luted vessels and covered with hematite ore in layers. The heat has to be slowly raised, twenty-four hours being occupied in bringing on a red heat, while the decarbonizing process goes on, in some cases, for three, four, or five days longer. Among some American makers, oxyd of zinc is used as a decarbonizing agent, in preference to other agents as the more successful. We think, however, that our producers of malleable cast-iron are too hasty in the manufacture to produce a good article; at any rate, they often give us a comparatively worthless article.

## Paint Room.

### COMPOSITION OF PAINTS.

BY H. HARPER.

(Continued from Page 124.)

The practice of adulterating pure linseed-oil, by destroying its glutinous properties, has changed its nature; how done, explained—"Paint-oil," a miserable substitute for linseed-oil—Spirits of turpentine: the pure article; how tested—Benzole—"Valentine Spirits" an improvement over Benzole—The nature of linseed-oil may be so changed, as to readily mix with water—The "Meloniline Oil" speculation—The Author concludes (we think sensibly) by hinting, that in order to keep posted, the public ought to patronize "the organ" of the craft extensively.

**LINSEED-OIL.**—In this fast age, when so many and pretended improvements are being developed, it is more than usually necessary for us to look around for old landmarks to enable us the more readily to adopt the good and reject the worthless. To reject everything new indiscriminately, is as fatal to our interest as it would be to adopt every whim that speculative genius presents.

Linseed-oil, which is now generally used in the common kinds of painting, and in manufacturing varnishes, of late years has been adulterated with substances which have completely changed its nature, or, which have, of themselves, a different nature from what is required. So far as the first appearance is concerned, the deception is complete. Flaxseed, out of which the pure linseed-oil is made, differs essentially from that of any other vegetable from which oil is expressed. Although there are other vegetable oils which are preferred for artistic painting, on account of retaining the color better when protected from the atmosphere by varnishes, yet it is a matter of doubt whether any other oil has the drying quality neces-

sary to resist the action of the atmosphere, water, &c., as well as the pure linseed-oil.

If flaxseed is subjected to a boiling or steeping process in water, it forms a thick gluey mucilaginous substance, that, when dried, is with great difficulty made soluble in water. This substance is a mixture of oil and glue together; the glue is soluble in water, the oil is not. Again, the oil is far more readily decomposed by oxygen than the glue. The composition of these two substances together, as they are when pressed from the flaxseed, forms a compound peculiarly adapted for spreading over the thing we wish to protect from the air and water. The oily substance prevents the water from dissolving the glue, and the glue prevents the oxygen from eating up the oil to a greater extent than any other compound we can get. For this reason we think that the nut-oil used by artists in fine paintings, although better for preserving the color, yet is not so great a protection against the action of the atmosphere as the linseed-oil. We should, above all things, be the more careful about destroying this natural compound, which seems so well adapted for the uses we have applied it to, for the sake of gaining an object of less importance—such as rendering the oil quick drying, by heating it to a high temperature. The heat destroys the nature of the glue part of the compound; and by practical experiments with boiled and raw oils in painting, it is found that the raw oil will resist the action of the atmosphere better than the boiled oil. If something is added to raw oil to make it dry quick, that has the same chemical effect that heating it would have.

The combination of lime and glue in a buck's horn will illustrate the above proposition. Buck's horns, of the elk species, are found scattered plentifully over our Western prairies in almost every stage of decomposition. By comparing these different stages of decomposition with what we have observed of their lasting qualities, we conclude that some of these horns must be from 50 to 70 years old. I was surprised to see a beautiful quality of glue extracted after boiling up these old horns, which had already begun to decay, by some of the knowing first settlers in the West,—but it was really so. What we wish to illustrate is this: that if these buck-horns had been exposed throughout to the same degree of heat that we heat linseed-oil in boiling, it would have destroyed the glue entirely; and when exposed to the atmosphere afterwards, as we all know, it would soon become a carbonate of lime. We should remember, what would destroy glue in horn would do the same in oil. This glutinous substance is what makes linseed-oil adapted to painting, over other oils.

A few years ago, at a time when flaxseed had become scarce and oil had gone up to a high price, a substitute was prepared to take the place of linseed-oil. This article was called "paint-oil," which was nothing more than oil distilled from stone coal. Circulars were sent around to painters, by dealers, requesting them to try the *new oil* on coarse painting. I watched with great interest the results of these experiments. At first, appearances were very much in favor of the new article. It looked well, and appeared to be just as substantial a covering as the linseed-oil would make. But this illusion was of short duration. In one year's time, the paint that at first adhered so firmly, soon afterwards could be rubbed off as easily as if it had been mixed with the purest water. The oil wanted the addition of glue to prevent the oxygen

from eating it up. The results of these experiments with "paint oil," brought it into disuse, except where an unprincipled or ignorant painter occasionally "sold" his employer, by mixing it with linseed-oil. When the natural cause of this failure is understood, it teaches a useful lesson. But when it is only known as a failure, without understanding the cause, it is pregnant with future mischief (as ignorance always is) in every department of art.

When our national troubles commenced, the northern portion was cut off from the supply of oil-of-turpentine, and which was a staple of one of the so-called Confederate States. This oil-of-turpentine (called spirits) is a volatile oil, which, when pure (if it is spread upon a sheet of white paper), will so completely evaporate, that it will not stain the paper. On account of its limpid and volatile nature, it was found useful and supposed to be indispensable for mixing with linseed-oil and paints, to render them the more easily spread with a brush. If pure linseed-oil was used alone in mixing paint, after it dried, the coat of paint would expand so that it would cover the surface with wrinkles. It was found in fine painting that the turpentine evaporating from the oil, left the paint more brittle, so that it could be polished smoother. These advantages were all derived from the nature of turpentine—that it would mix with oil, and after being spread, would entirely evaporate. The advantages by using it in varnish were of the same nature. Such was the nature of the article of which we were deprived suddenly, and for which we were compelled to find a substitute. Those who were engaged in manufacturing of varnish, and in the paint and oil trade, took hold of the matter with commendable energy and ingenuity. How many disappointments were encountered in all the various experiments that were made to find a substitute, will perhaps never be known; but, one thing is certain, there were thousands of active minds bent upon this one subject.

The discovery of Benzole—an article somewhat allied to coal oil—was hailed with joy for a time, supposing it was the article that was going to fill the place of turpentine, both in paints and varnish. This article was soon found to be only one grand step towards the final result. Benzole would partially mix with oil and with gums; but in most cases it was only a delusive mixture, for it would separate from oil, and would not hold gums in complete solution, particularly with shellac, which is used for making japan; it would separate so completely from the gum after standing awhile, that it was entirely worthless. The "croakers," whose legitimate business is to talk—not to think—cried out unanimously, "I told you so; painters never will find anything that will answer as well as turpentine."

Fortunately for painters, down in the old Bay State, where so many good things come from, a mind capable of thinking,—which had also the means of experimenting—was, at work. Scarcely had the "croakers'" echo been sounded back from the most distant parts of our land, before Messrs. Stimson, Valentine & Co., of Boston, presented their "Valentine Spirits," recommended by some of our most experienced painters as almost equal to turpentine.

Valentine Spirits hold all gums used in varnish completely in solution; mix perfectly with linseed-oil, without chemically changing its nature; completely evaporate from the oil and varnish the same as turpentine. It evaporates a little sooner than turpentine, making it a

little more inconvenient to those who have always used and spread turpentine varnish. Hence comes the very honest qualification of those painters, compared with turpentine. As a painter, I do not think it should be classed thus; but that turpentine should be named as almost equal to Valentine spirits. If old painters will look back to their juvenile days of painting, they will remember how difficult it was for them to spread evenly a coat of paint (called flattening) that was mostly mixed with turpentine, on account of its evaporating too soon. However, they soon got over that difficulty, so that they could spread that kind of paint without the least inconvenience. We cannot say how the difficulty was overcome, any better than to say that we got used to it. It is precisely the same in using Valentine spirits, after first becoming accustomed to the use of turpentine. A very short time and we will be used to it, so that we shall not think it inconvenient; and the painter who makes that as an objection, will be regarded as a new beginner.

I do not mean to say that varnish or japan must necessarily be good, even if it will mix with Benzole. *Water-oil and shellac can be mixed by chemically changing the nature of the oil*, and it has been done in some locations as an article of trade, and called "double-boiled oil." It has been known for many years that, after boiling gum-shellac in water, it would become soft, or melted into a semi-liquid state. When in this state, by adding potash, or any of the alkalies in a sufficient quantity, the shellac would dissolve with the water; then, by adding linseed-oil, the alkali would change the oil into a thin liquid soap, which would readily mix with the water. A recipe for this compound was several years ago sold around to painters as a recipe for mixing water with oil. Some four or five years ago, a patent was granted on it to some persons living in the United States, who called the compound, "Meloniline Oil." We find this patent recorded in the patent record of inventions in this magazine, and further, we believe not many painters have heard from it. But it has not been lost to the world. It was sold to men who, in some cases, were ignorant, and others who did not care how much injury they did to paint-work. They manufactured what they called "boiled oil," or, in some cases, "double boiled oil," simply by mixing this preparation with raw oil. It gave it the color of boiled oil, and either the drying quality or else a dryer was added. So complete was the delusion to painters, that they congratulated themselves on getting the very best quality of boiled oil almost as cheap as raw oil. I used it for one, and never thought of a trick until I was "blowed up" several times by my customers about my paint not lasting. This unpleasant circumstance sharpened my perceptive faculties, so that from the knowledge I had of the above compound, and the time the patent record showed that this patent was issued, I was enabled to trace out the cause of the defect in my paint. Fortunately, at the same time, I got some information from a workman who had been employed to boil oil for a large Western paint store, who told me about the process of mixing a strong dryer, in the shape, as he supposed, of boiled oil, with raw oil in the proportion of one to ten. His employer had paid \$50 for the use of the patent in his own factory.

These details would be uninteresting, if there was not a useful lesson to be drawn from them. We are far from our course of duty, equally far from the course

that will advance our own personal interests, if we do not contribute our mite in the recording facts pertaining to the interest of our own craft, so that those who have a desire to do their duty, in the position which they have chosen for a life of usefulness, may have some kind of a chart whereby to "shun the rocks on which others have split." Consequences fraught with the most serious injuries to communities as well as individuals, are an every day occurrence, and may be avoided by circulating knowledge of things pertaining to the interests of any craft, no matter how low down in the scale of mechanism it may be. The "Meloniline Oil" is a case in point when traced out through the exposure of one individual. A man who, ignorant and unprincipled, goes to another who is so ignorant of the nature of oil that he does not know when he is tampering with its best qualities, with a tempting bait, he engages him to palm off a worthless thing—a thing that he had made worthless—upon the community at the rate of thousands of dollars yearly. Mechanics were deceived. There was something wrong, but they could not tell exactly what. This cheat, which drew from the pockets of men thousands and tens of thousands of dollars, could have been smothered at first, had a painter, who understood the old principle of mixing oil and water, but cast his eyes upon the claims in the patent record. A thing that was made public, for the want of knowledge among mechanics, did an injury that would sound fabulous, if computed in dollars and cents. Not exactly for the want of a circulative medium, either—for that we had—but for want of the support we withheld from that medium.

My own ignorance on this subject, through delinquency in not keeping posted, made me draw upon my patrons to the tune of several hundreds, which I could only pay in unavailing regret.

(To be continued.)

## Trimming Room.

### EXTRAORDINARY RISE IN CARRIAGE TRIMMINGS.

IN our last issue we reported an anticipated rise in the prices of carriage trimmings, but confined our fears in this respect more in relation to those imported from abroad, such as cloths, reps, cotelines and satins, not expecting to find so large an advance on goods of domestic manufacture, in the space of only one month. Such, however, is the inflated state and tendency of all business, caused by the extraordinary high premium on gold, that the leather manufacturers, treading in the footsteps of others, "go in" for the largest profits. Leather has again advanced from 27 to 30 cents on the pound over our last quotations. The price is 33 per cent. above the report as made twelve months since, as a comparison with our Price List will show. This surely cannot be in consequence of any scarcity in the raw material, for the needs of our soldiers has required a great destruction of cattle, and left a consequent supply of skins. We infer it is all owing to the high price and scarcity of *bark*!

The Union cloth (cotton and wool), so long a favorite with our country friends, has likewise gone up full 20 per cent. on former quotations. There are many other articles for which an increased figure is demanded in our list,

this month. Indeed, there seems to be no limit to the rise, and to-day's report may be entirely changed tomorrow. The strangest thing of all is, that although manufacturers and dealers advance with the rise in gold, yet they never recede or fall when that comes down, or at least this is our experience. This is rather disagreeable to purchasers, especially to one accustomed, as we are daily, to buy for parties distant from New York, and who are not accustomed to the constant changes and hazards of trade. With the market thus unsteady, our friends must make some allowance when they find our purchases for them rule higher than the latest report.

## Editor's Work-bench.

### CARRIAGE-BODY MAKING.

No part of our business demands so much care and nicety as building bodies, and, to begin right, this labor should never be undertaken without putting everything about the work-bench in good order—especially the tools—these should be all newly ground and made sharp. There are few pieces of architecture requiring more mechanical skill than carriage-bodies, and although it has often triflingly been said "that a good mechanic was one who did not need tools," we have never yet come across one who could make a *good* body without *sharp* tools, as well as ingenuity. We can generally decide as to the ability of a workman, as soon as he unlocks his work-chest, and disposes of his "kit" about his bench. A very nice workman is he who is nice with his tools. We are soon led to distrust the careless jour, who permits tools, shavings and dust to collect all over his bench, where, to find a tool, he may be obliged to overhaul the entire mass, to the manifest waste of time and good expenditure of patience. Another thing: a workman should early so accustom himself as never to be obliged to make it necessary to do his work over the second time. This was the first injunction we obtained from our boss, and it has never been forgotten by us. It has been the secret (we say it with deference) of much of the credit we have received for being a fast workman. It has enabled us to build two paneled gig-bodies in eight days, when we had to saw by hand all our own stuff.

Some lose much time by the way in which they "dress-up their stuff." They merely dress-up a portion, and then begin to frame. This, too, is wrong. Every stick, that can be, should be dressed for framing before a tenon or mortise is made in any part. This operation may be facilitated by following the directions of a correspondent, under the head of "Timber marked by pattern on both sides," on page 231, volume three, of this Magazine. In the whole process of building, system is essentially necessary; without this, nothing goes on right.

When we come to the framing part, great care is necessary. If the operation of mortising is preceded



by boring, as it should be, pains should be taken to have the bits narrower than the width of the mortise, for apparent reasons. Mortises should, in all cases, be smooth filed, and in most instances, left a little rounding, so as to pinch in the center, as well as at the edges. We have known many professedly good workmen make, invariably, *hollow* mortises, for the sole purpose of having *tight joints* on the outside—a very poor reason. Much labor is also saved by sawing instead of cutting the tenons. Be sure and have your tenons full, so as to fill the mortise well. Care in this respect has often saved manual labor, mental pain, and money.

Another thing: having framed the body to correspond with the draft, and far enough to have ascertained the length of the panels, bottom, &c., the earliest opportunity should be embraced to plane all up, and have them thoroughly dry when worked. This precaution—if indeed it has not been done before framing—has saved many workmen the trouble of putting in a second panel. Neglect here, we judge, is the chief reason “why panels split.” See volume two, page 4. We pass on, simply observing that a pillar tenon may often be strengthened by the aid of a good long wood screw through the bottom side (outside of the tenon) into the pillar, parallel with the tenon.

Many workmen—and they have a long custom for the practice—employ wedges to secure their panels in place in the grooves. This is another custom “better followed in the breach than in the observance.” It is certainly an expeditious way of spoiling an otherwise nice job, particularly when done by the young beginner. A much safer and better way is to substitute glued strips of canvass, pressed in by a properly formed wooden corking-iron, if we may be allowed to call it such. When properly done and become hardened, this renders all solid and firm. There are many other matters in body-making, which we must defer until another time, all worthy the attention of the youthful practitioner, yet sneered at by some of the “old fogies.” The “tricks” of such *old dogs* we despair of reforming.

#### EMPTYING THE PURSE INTO THE HEAD.

FRANKLIN sagely advised the men of his time to “empty their purses into their heads, and then no one would ever be able to get them away from them.” The caviler may say that the old printer and philosopher acted from selfish influences; but there can be no question in regard to the fact that “knowledge is power,” and that this power is very readily turned into money, with good interest. Many have tried the experiment, and found it a profitable investment; more may, and meet with like success. We do not know of a single class of mechanics who could better carry out the Doc-

tor's advice, than carriage-makers. Unlike the shoemakers, and some other occupations, when night comes business is over, and time for study given. This time, faithfully improved, will elevate the student individually, and gain respect for the craft generally. As Webster remarked on one occasion, “there is plenty of room higher up” in all professions, and he who attains to the highest grade, is sure to find the richest rewards. Who doubts that the more study a carriage-maker lavishes on his business, the more perfect he will become in all its details.

A few years ago, a machinist's apprentice, poor and with a mind undeveloped, appeared in the streets of Worcester, Massachusetts, in such an unpromising garb that he was the mark for popular ridicule. But he soon got into the way of putting gains into his head. These soon elevated him in the estimation of his shopmates, and it was not long before he had bought out the establishment of his employers. Our readers have an example of what time and study will accomplish, as related in the biography of Mr. James Brewster, and published in the First Volume of this Magazine. He tells us he made it a rule to read one hour each day, after working his twelve hours; and his whole life-conduct is a fair example of what may be gained by “emptying the purse into the head.” This is further illustrated in the words of a contemporary: “Forty years ago, a lad toiled for his daily bread in the forests of the West. There were scarcely ten books in as many miles, yet he put investments into his head. He had no genius, but he had, in its place, many disadvantages. He had no wealth. He was not prepossessing; he was extremely uncouth—but he put his gains into his head; and to-day he holds the highest place of any man upon the earth, with no enemies but the enemies of liberty.”

No one need plead, as an excuse for wasting his leisure hours in folly, that mental labor is too much for human nature when tacked on to a day's manual exercise. One hour each day devoted to study—not mere reading—will give an individual a very clear insight into a science in a month; and for close thinking, no student is better prepared than the mechanic, after his day's toil is ended. While his muscles are resting, he acquires, if he is wise, a new zest for study—a zest no person entirely devoted to mind-culture ever is favored with. With the day's labor finished and business over, there is ample time to study and inwardly digest the mental food, happily in our time spread cheaply before all. In the hours of toil through the day there is ample time to make the thoughts of others our own. Judicious reflection may evolve some great principles, which will be a joy to you for ever. Let the reflection that “knowledge is power, is wealth, is honor,” incite to diligent action, and this action, wisely directed, will soon show the world that the

word *mechanic* no longer means "a mean workman," as Johnson defines it, but the embodiment of all that is noble.

### UNION NECESSARY

AMONG no class of mechanics in the whole country is there less concert of action than among carriage-makers, and among no others is there greater necessity for it. Every individual appears to think he can manage his affairs alone, shut up within his own shop, with the curtain down, so as to prevent his neighbor from knowing how business is carried on inside, lest somebody should find out some secret he has the vanity to imagine an original idea hatched within his own brain. This hermit-like conduct on our part (we know not what else to term it) works to the disadvantage of the craft as a body. What else can be expected from such Diogenes-in-his-tub-like action? Other tradesmen combine for self-protection. Why cannot American carriage-makers?

Whilst this inexcusable selfishness has closed our doors to our neighbors, our natural enemies—renegades too idle for honest industry—have seized upon the opportunity thus afforded them to take from us the hard earnings our toil has brought us. At no time has the craft suffered from those we allude to more than they do now, since business has once more revived. We know of an instance where not less than sixteen cases for alleged infringements on pretended patents are now pending, not one of which has yet been allowed to come to trial, and probably never will. Those alluded to, although checked by certain documents, still send out their fulminating missiles, threatening to bring all the terrors of the law upon some poor rural carriage-maker, unless he comes immediately up to the captain's office with the dust and settles: No one, in our position, can view these matters with unconcern. Our table literally groans with complaints in letters from various quarters, stating that they (the writers) are threatened with a lawsuit, a specimen of which we give *verbatim*, only suppressing names:

NEW YORK, July 29th 1863

DEAR SIR! I have send you three letters since April 10th to which you made no reply. I placed the matter of infringements into the hands of Mr. — and he wrote one last that you would make no statement in regard to infringements. Now if you persists in your dishonorable course you will make your case a very bad one for you, as I shall feel sorry to force you. I hereby notify you that you must make a statement within 10 days and settle the matter within that time as after that time you will not have an opportunity to do as well.—I shall issue a subpoena from Court and make you answer to a complaint and compel you to make a statement. Yours, etc.

No one for a moment will suppose that such a system of doing business could be long practiced were the members of the craft to form a Protective Association, and battle unitedly in cases where the law-fighting is now done singly. Why, we ask, is there so much indifference shown in matters of so much and vital interest to the

craft generally? We do not believe it would be suffered by any other class of artisans.

Those who follow the practices complained of are generally persons who have failed in other businesses, and now resort to this way of obtaining a subsistence, *soured* with all the animosity their perverted natures can exercise, under the belief that the world owes them a livelihood, and somebody must feed them!

We have not space to follow this subject further here, and must close, with the explanation that, in what we have said, we intend no censure to such as have invented and honestly patented some original article, but refer to such would-be inventors as appropriate and live off of the genius of others, wrung out of men's fears of a lawsuit. As we have elsewhere said, a combination would soon end such questionable kinds of business.

### BOUND VOLUMES AND COVERS FOR BINDING.

OUR friends have for some time been calling for sets of this Magazine, bound, which we have not been able to furnish. We would inform them that we have remedied the deficiency, and now supply their orders—the first three volumes at \$3.50 each, and the fourth volume at \$4. When sent by mail, 50 cents on each volume must be added to prepay postage, or they cannot, in accordance with the postal law, be sent. We have likewise had a few covers for Volumes Four and Five made to accommodate our subscribers. These are charged—75 cents at this office, or 85 cents by mail, postage paid. Those who desire them had better send at once, as we shall not get up any more very soon, and only do so now because we are pressed into it by a demand. The great cost of material, &c., makes them come high, but we cannot afford them any less, and get our money back again. Send along your orders.

### REVIEW OF TRADE.

WE learn from a private source that carriage-making is very prosperous in Boston, Mass. Every shop has about as much as it can do.

In New Haven, where the southern rebellion struck such a severe blow to the interests of carriage-makers, matters are improving, in consequence of an increase in western customers. Many carriages are built for Chicago and other places.

Rahway and Newark are looking-up again, having obtained a limited number of orders from New York dealer

Carriage-makers in this city have about as many orders as they can conveniently fill. There is a new encouragement given to the trade here, by the fact that workmen are not so difficult to obtain now, as they were last summer.

In the Western States trade has very much improved, and we think it must continue to improve, now that it has a currency which it can depend on, altogether different from the trash in circulation before the war, which was based on Southern stocks, and "shaky." "Greenbacks" are found to have a magical effect upon trade everywhere, and are not despised, even in Dixie, however much they turn up their noses at everything else from Yankeedom.

#### EDITORIAL CHIPS AND SHAVINGS.

**BILL JINGLE IMITATED.**—A Parisian carriage-builder has invented a singular vehicle, intended for the convenience of invalids. It is very much on the Bill-Jingle-plan, [see Vol. 1., p. 56, of this Magazine] opening in the center, with a seat made to descend to the ground by means of a screw. The invalid being placed inside, the seat is raised and fastened in its proper place with great facility.

**NIGHT AND DAY TRAVELING.**—The *Railroad Advocate* sums up the advantages of night over day travel by railroad, very strongly. It says that at night all work on the track ceases, and there are but few trains running. Drawbridges are generally all closed, and switches are not so liable to be misplaced, as they are less used; the signals for trains are more certain, for lights are used and can be seen further. The engineer has nothing to divert his attention by night. Rocks and trees are no more liable to fall upon the track by night than by day, nor are cars more likely to break at one time than at another. Passengers in a night car are more apt to keep their seats and remain quiet, and that is the safest thing they can do in a railway car.

**WHOLESALE SEIZURE.**—In a long article, written in a spirit of despair, *The Richmond Whig* talks after this manner: Conscribe the entire white population within the ages of 18 and 50; constitute a reserve corps of the lads between 15 and 18, and the men between 50 and 60; abolish all details for teamsters, orderlies and ambulance drivers, and fill the vacancy with negroes and mulattoes, and it is easy to see what the consequences will be upon agriculture. It was a matter of doubt, last spring, whether the hack, carriage, dray, cart, and indeed, all the horses in the city, not indispensably necessary to the business of the government should not be seized. With the stoppage of farm-labor and the seizure of all the horses in the Confederacy, how much longer will the "chivalry" be able to carry on the war?

**HARPER'S AXLE GAUGE.**—Lest some may think this Gauge, of which we gave illustrations and a description last month, unsuited to all widths of track, the inventor furnishes the following in relation to such objections: "It is possible that the gauge is 4 or 5 inches too short; but, even with that disadvantage, it can easily be applied to gauge an axle for 5 feet 5-inch track. The two crescent-shaped rests are 55 inches apart, consequently on a 55-inch track, they will reach from center to center of the axle arms, and the set screws extend 5 inches on each side of them, to the extremes of a ten-inch arm. Now, if the track makes the axle 65 inches from center to center, the farthest screws on the gauge will reach to the center of the axle, and the set-screws further in, on the gauge, will extend five inches towards the collar, if the axle has a

10-inch arm. This would be exactly the same as if you had got the angle to the whole length of the arm, for it is exactly the same on each side of the center of the arm. You will see, on a moment's reflection, that if you get the exact gauge of two or three inches on an axle arm, that is just as well as if the whole length of the arm is gauged, for it is all of the same angle. When the axle is set, there is no more probability of a mistake than there is in subtracting one number from another; yet, with all these *truths* in its favor, mechanics use arguments against it, when they do not understand it, and they are sure to urge these arguments. I have a powerful rebutting argument, that tells with force in this section of country. A wagon set by this gauge will sell from 10 to 25 per cent. more than one that is not. No matter how much sophistry is used to make people believe that the question of setting axles perfectly has been practiced before, every job that is turned out contradicts it as soon as the case is fairly presented. Our friend evidently thinks "facts are stubborn things," and, therefore, he offers to forfeit a thousand dollars to any man who will set an axle as quickly and correctly in any other way.

#### LITERARY NOTICES.

WE would direct the attention of our readers to *The New England Historical and Genealogical Register and Antiquarian Journal*, a quarterly publication of the deepest interest to all genuine lovers of American history. The January number is embellished with a portrait and several other engravings. The literary contents are sketches of the lives of Gen. David Cobb and Dr. Jonathan Potts; an account of the discovery of an ancient ship on the eastern shore of Cape Cod; together with some forty different articles on interesting subjects—biographical, historical, and genealogical. Each number contains 112 pages, and is published at Albany, N. Y., by Joel Munsell, at the low price of \$2 a year.

Our old favorite, *The Atlantic Monthly* for February, has come to hand. The contents are—Genius; My Brother and I; A Half-Life and Half a Life; On the Relation of Art to Nature; Snow; House and Home Papers; The Convulsionists of St. Medard; Presence; Special Period; Bryant; Annesley Hall and Newstead Abbey; The Last Charge; Northern Invasions; Reviews and Literary Notices. A very interesting number.

#### AMERICAN PATENTED INVENTIONS.

OCT. 27. IMPROVED METHOD OF ATTACHING CARRIAGE WHEELS.—J. H. Reimkasten, of Franklin Grove, Ill.: I claim a divided nut, constructed and applied substantially as described, to confine the arm, C, within the box, A, when used in combination with screws or bolts, *d*, to secure the divided nut upon the collar, and with a screw, *d*, to prevent the turning of the nut within the box.

NOV. 17. IMPROVED VEHICLE SPRING.—Eliphalet C. Brooks, of San Francisco, Cal.: I claim the shackles or bars, B, connected together and applied to the axles, AA, as shown in combination with the curved bars, EE, L, and the springs, II, and K, with or without the rubber, *e g c'*, all arranged substantially as and for the purpose herein set forth.

NOV. 24. LUBRICATING AXLE.—J. F. Hinman, of Battle Creek, Mich.: I claim the combination of the elastic band, E, and its groove, *a*, with the cover, F, and oil orifice, D, in the manner herein shown and described, and for the purpose described.

## CURRENT PRICES FOR CARRIAGE MATERIALS.

NEW YORK, February 18th, 1864.

Apron hooks and rings, per gross, \$1.25.  
 Axle-clips, according to length, per dozen, 75c. a \$1.  
 Axles, common (long stock), per lb, 10c.  
 Axles, plain taper, from  $\frac{1}{4}$  to 1 in., \$6;  $1\frac{1}{2}$  in., \$6.50;  $1\frac{3}{4}$  in., \$7.  
 Do. Swelled taper, 1 in. and under, \$6;  $1\frac{1}{2}$  in., \$7;  $1\frac{3}{4}$  in., \$8.50;  $1\frac{1}{2}$  in., \$10;  $1\frac{3}{4}$  in., \$12.  
 These are a superior axle, and more frequently called for than any others.  
 Do. case-hardened, half-patent,  $1\frac{1}{2}$  in., \$7;  $\frac{1}{2}$  in., \$7.50;  $1\frac{1}{4}$  in., \$8.50;  $1\frac{3}{4}$  in., \$9.  
 These are prices for first-class axles. Makers of less repute, cheaper.  
 Bands, plated rim, under 3 in., \$2; over 3 in., \$2.50.  
 Do. Mail patent, \$2.50 a \$3.75.  
 Do. galvanized,  $3\frac{1}{2}$  in. and under, \$1; larger, \$1 a \$2.  
 Basket wood imitations, per foot, \$1.  
 When sent by express, \$2 for a lining board to a panel of 12 ft.  
 Bent poles, each \$1.12 $\frac{1}{2}$ .  
 Do. rims, under  $1\frac{1}{2}$  in., \$2.25 per set; extra hickory, \$2.50 a 2.75.  
 Do. seat rails, 44c. each, or \$4.50 per doz.  
 Do. shafts, \$6.  
 Bows, per set, light, 85c.; heavy, \$1.12.  
 Bolts, Philadelphia, add 40 per cent. to printed list.  
 Do. T, per 100, \$3 a \$3.50.  
 Do. tire, \$1.25 a \$1.80 a \$2.40, according to size.  
 Buckram, per yard, 30c.  
 Buckles, per gross, 88c. a \$1.25.  
 Burlap, per yard, 25c.  
 Buttons, japanned, per paper, 15c.; per large gross, \$1.75.  
 Carriage-parts, buggy, carved, \$4.  
 Carpets, Brussels, per yard, \$2; velvet, \$2.75 a \$3; oil-cloth, 60c. a 80c.  
 Castings, malleable iron, per lb, 15c.  
 Clip-kingsbolts, each, 35c.  
 Cloths, body, \$3.75 a \$4.50; lining, \$2.25 a \$3.25. (See *Enameled*.)  
 A Union cloth, made expressly for carriages, and warranted not to fade, can be furnished for \$2.25 a \$2.50 per yard.  
 Cord, seaming, per lb, 25c.; netting, per yard, 5c.  
 Cotelines, per yard, \$6 a \$8.  
 Curtain frames, per dozen, \$1 a \$1.50.  
 Do. rollers, each, 75c. a \$1.  
 Dashes, buggy, \$1.75.  
 Door-handles, stiff, 50c. a 63c.; coach drop, per pair, \$2 a \$3.50.  
 Drugget, felt, \$1.62.  
 Enameled cloth, 5 qrs., 75c.; 50 in., \$1.55.  
 Enameled cloth ranges from 80c. to \$1.55, according to width and quality.  
 Enameled linen duck, 4 qrs., 55c.; 5 qrs., 75c.; 52 in., 90c. Colored, 15c. higher per yard.  
 Felloe plates, wrought, per lb, all sizes, 18c.  
 Fifth-wheels wrought, \$1.38 a \$2.  
 Fringes, festoon, per piece, \$2; narrow, per yard, 18c.  
 For a buggy top two pieces are required, and sometimes three.  
 Do. silk bullion, per yard, 35c. a 75c.  
 Do. worsted bullion, 4 in. deep, 35c.  
 Do. worsted carpet, per yard, 6c. a 10c.  
 Frogs, 50c. per pair, or \$1.63 per dozen.  
 Glue, per lb, 25c.  
 Hair, picked, per lb, 30c. a 60c.  
 Hub-borers (Dole's) for light work, \$15; heavy, \$18 a \$20.  
 Hubs, light, morticed, \$1; unmorticed, 75c.—coach, morticed, \$1.50  
 Japan, per gallon, \$4.75.  
 Knobs, English, \$1.75 a \$2.  
 Laces, broad, silk, per yard, 85c.; narrow, 12c. to 15c.  
 Do. broad, worsted, per yard, 37 $\frac{1}{2}$ c.  
 Lamps, coach, \$14 a 18.  
 Lazy-backs, \$9 per doz.  
 Leather, collar, dash, 29c.; split do., 18c. a 30c.; enameled top, 29c.; harness, per lb, 50c.; flap, per foot, 25c. a 30c.  
 Linen, heavy, a new article for roofs of coaches, 55c. a 70c. per yard.  
 Moquet,  $1\frac{1}{2}$  yards wide, per yard, \$5.50  
 Moss, per bale, 10c.  
 Mouldings, plated, per foot, 12c. a 15c.; lead, door, per piece, 30c.  
 Nails, lining, silver, per paper, 6c.; ivory, per gross, 25c.  
 Name-plates.  
 See advertisement under this head on 3d page of cover.  
 Oils, boiled, per gallon, \$1.50.  
 Paints. We quote white lead, extra, \$3; Eng. pat. black, 25c.  
 Pekin cloth, per yard, \$4.50.  
 A very good article for inside coach linings.

Plushes, per yard, \$2 a \$3.  
 Pole-crabs, silver, \$5 a \$6; tips, \$1.12.  
 Rubbing stone, per lb, 12c.  
 Sand paper, per ream, \$4.50.  
 Screws, gimlet.

Add to manufacturer's printed lists 20 per ct.

Do. ivory headed, per dozen, 38c. per gross, \$4.  
 Serims (for canvassing), 18c.  
 Seats, buggy, pieced rails, \$1.75; solid rails, \$2.50.  
 Shaft-jacks (M. S. & S.'s), light, \$2.60; heavy, \$2.87. a \$3.25.  
 Shaft jacks, common, \$1 per pair.  
 Do. tips, extra plated, per pair, 35c.  
 Silk, curtain, per yard, \$1 a \$2.25.  
 Slat-irons, wrought, per pair, 65c.  
 Slides, ivory, white and black, per doz., \$6; bone, per doz., \$1.50;  
 No. 18, \$1.75 per doz.  
 Speaking tubes, each, \$5.  
 Spindles, seat, per 100, \$1 a \$1.25.  
 Spring-bars, carved, per pair, \$1.  
 Springs, best temp. Swedes, per lb, 26c. a 27c.; black, 19 $\frac{1}{2}$ c.; bright, 21c.; best tempered, 25c.  
 Two springs for a buggy weigh about 28 lbs. If both 4 plate, 24 to 40 lbs.  
 Spokes, buggy, per set, \$3.60, or about 6c. each for all under  $1\frac{1}{2}$  in.  
 For extra hickory the charges are 7 $\frac{1}{2}$ c. each.  
 Steel, Farist & Co.'s Homogeneous American, per lb, 18c.  
 Do. English Homogeneous, do. 22c.  
 Do. Compound tire, from \$7.50 to \$8, according to thickness.  
 Stump-joints, per dozen, \$1.25 a \$1.50.  
 Tacks, 6c. and upwards per paper.  
 Tassels, holder, per pair, 63c. a \$1; inside, per dozen, \$3; acorn trigger, per dozen, \$1.25 a \$1.50.  
 Terry, per yard, \$7.  
 Top-props, Thos. pat., per set, 40c.; plain, com., 35c.  
 The patent props, with silver-plated nuts, per set, \$1.  
 Tufts, ball, per gross, 80c.; common worsted, 12c. a 25c.  
 Thread, Marshall & Co.'s Machine, No. 432, \$2.40 per half lb; No. 532, \$2.75 do.; No. 632, \$3.50 do.  
 Turpentine, per gallon, \$3.75.  
 Twine, tufting, per ball, 45c.  
 Varnishes (Amer.), crown coach-body, \$5 a \$5.50; hard drying, \$6; nonpareil, \$6.50.  
 Do. English, \$6.25 in gold, or equivalent in currency on the day of purchase.  
 Do. American imitation of English, \$7.  
 Webbing, per piece, 44c.  
 Whiffle-trees, coach, turned, each, 25c.; per dozen, \$2.50.  
 Whiffle-tree spring hooks, \$3 per doz.  
 Whip-sockets, rubber, per dozen, \$7 a \$9; pat. leather, stitched, \$3.  
 Window lifter plates, per dozen, \$1.50.  
 Yokes, pole, each, 75c. to \$1.25.  
 Yoke-tips, 50c. a 75c.

Our Prices Current this month show another rise in many of the leading articles. Springs have also advanced 1 cent per pound. We would remark that when our friends send us orders we can only be governed by the ruling prices for that day, and that there is no certainty that prices may not rise the next day after our report, so changeable is the market. Cash orders preferred. Where C. O. D. bills are forwarded with the goods by express, charges for collection must be added, which amount in ordinary cases to from 25c. to \$1, according to distances. All this may be saved by sending us the money with the order.

## TO READERS AND CORRESPONDENTS.

BACK VOLUMES of this work will be sold, in numbers, for \$3; when bound, for \$3.50, to which, if sent by mail, 48 cents must be added to prepay postage; if two or more volumes are called for at one time, they can be had for \$3 each, or will be sent by express, at the purchasers' expense, at the same price. The subscription to the Fifth Volume, now in course of publication, will be (in consequence of the advance in paper and printing) four dollars, IN ADVANCE, for the twelve numbers.

AGENCY.—Our friend Mr. Henry Harper, who is traveling in the West, is authorized to take subscriptions for us, and receipt for moneys paid; and any contract he enters into concerning this Magazine will be honorably carried out by the Publisher. In Canada West, Mr. Robert McKinley, at St. Catharines (dealer in carriage-hardware), will act as our local agent.



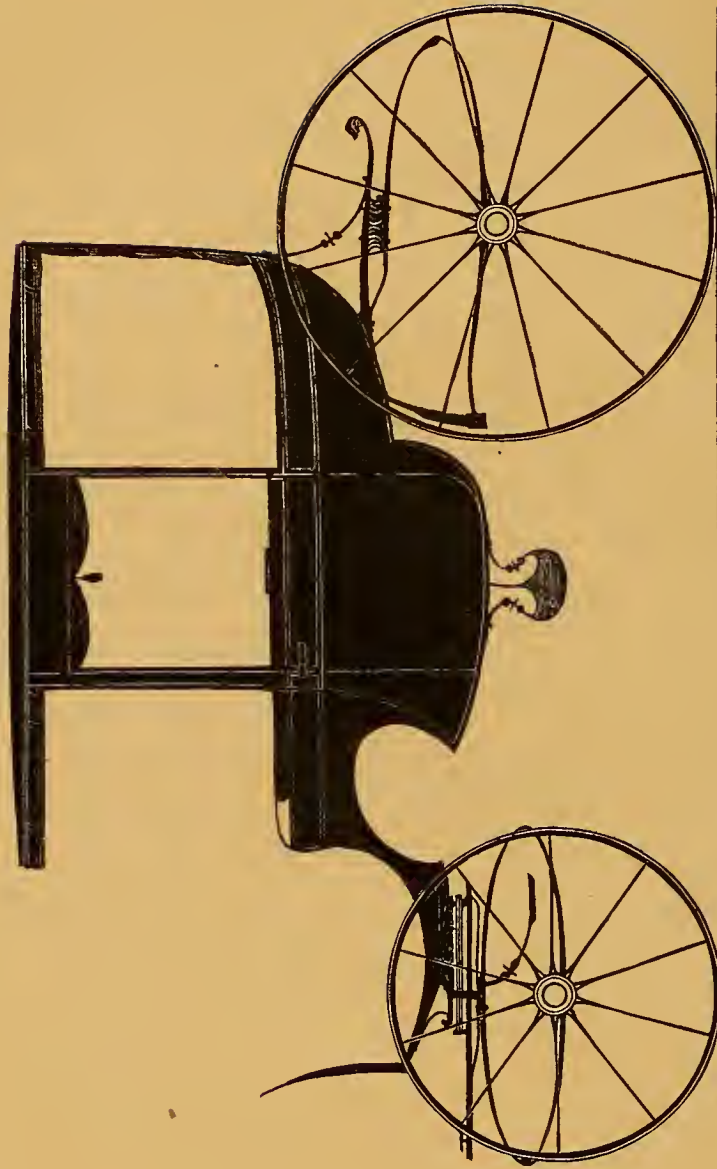

FOUR-PASSENGER COUPÉ ROCKAWAY.— $\frac{1}{2}$  IN. SCALE.

*Designed expressly for the New York Coach-maker's Magazine.*

*Explained on page 169.*

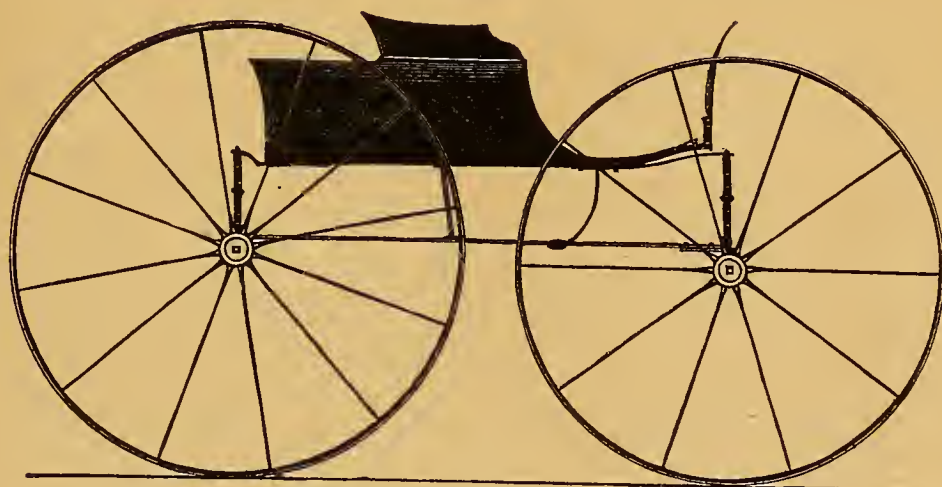

COAL-SCUTTLE BUGGY.— $\frac{1}{2}$  IN. SCALE.

*Designed expressly for the New York Coach-maker's Magazine.*

*Explained on page 169.*





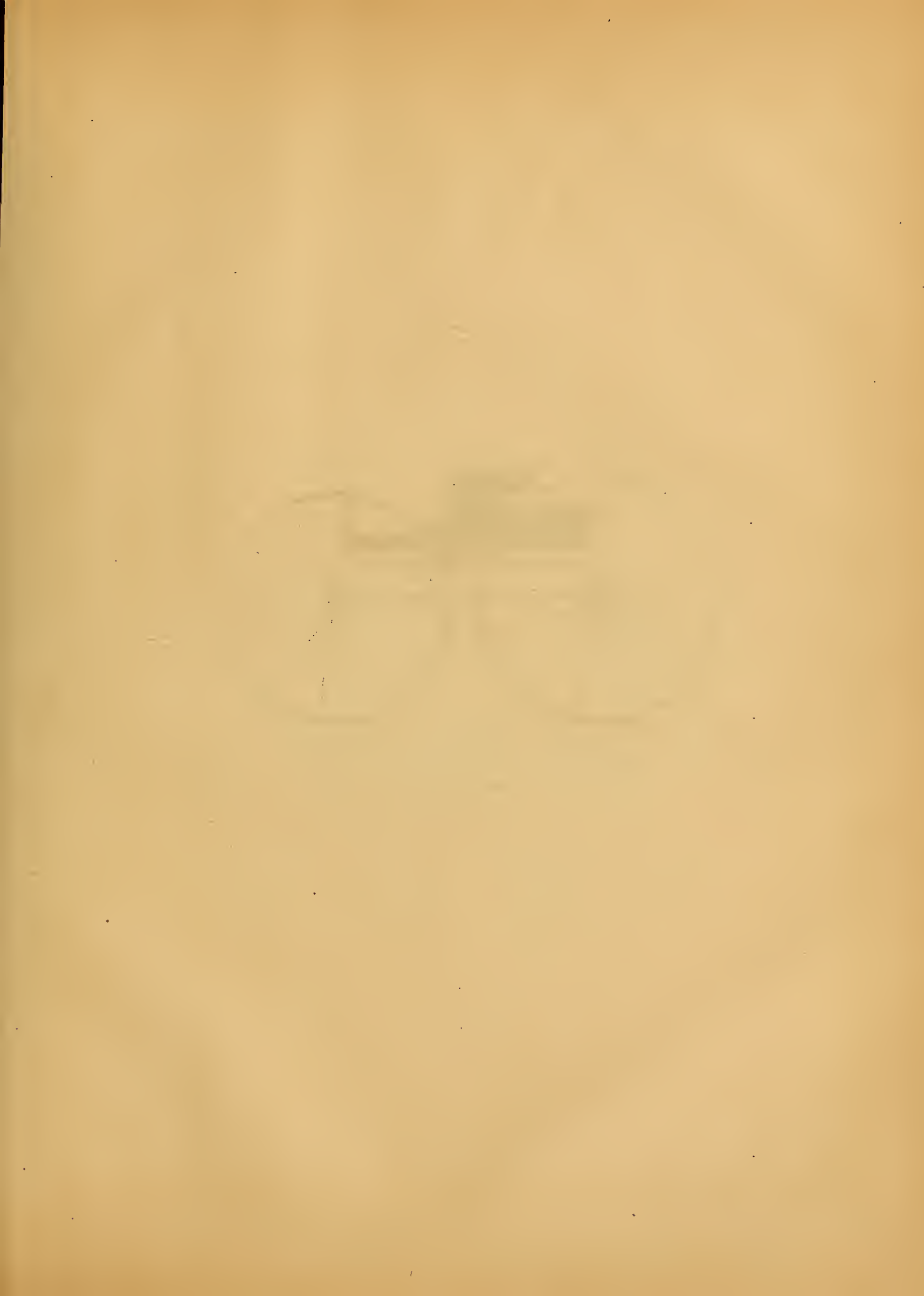

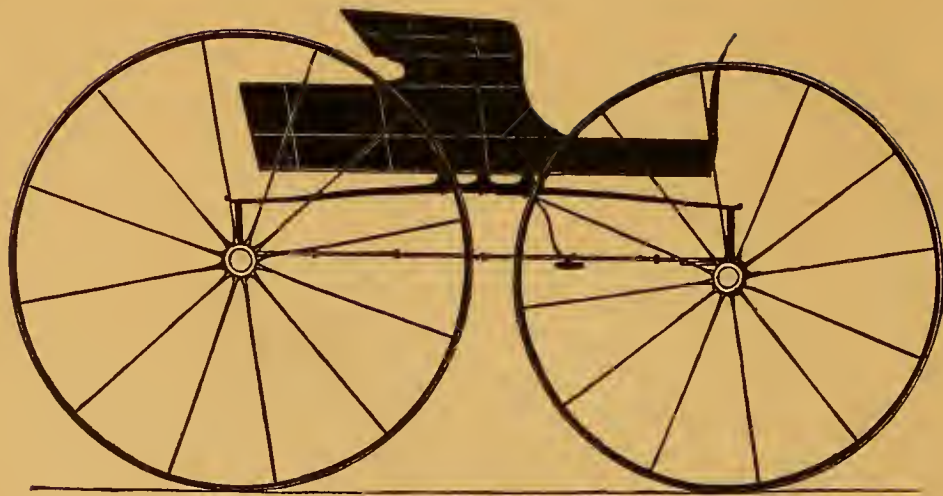

RIBBED BUGGY.— $\frac{1}{2}$  IN. SCALE.

*Engraved expressly for the New York Coach-maker's Magazine.*  
*Explained on page 169.*



ORNAMENTED GERMAN TEXT.

*Printed for the New York Coach-maker's Magazine.—See page 171.*





DEVOTED TO THE LITERARY, SOCIAL, AND MECHANICAL INTERESTS OF THE CRAFT.

Vol. V.

NEW YORK, APRIL, 1864.

No. 11.

## Mechanical Literature.

### IMPROVEMENT IN WHEEL-CARRIAGES.

BY S. EDWARDS TODD.

It is truly surprising to see what extensive improvements have been made, during a few years past, in the design and manufacture of wheel-carriages of almost every description, from a trotting buggy to a four-horse omnibus. And these good improvements are not confined to the cities and villages of our country.

Only a few years ago, the great mass of country people were accustomed to ride in almost anything that would carry them safely along; and, in a great many instances, respectable farmers carried their families to church, or to social gatherings, in the same vehicle with which all the heavy and dirty drudgery of the farm was performed. But the last decade of years has wrought a great change in this respect. Now, almost everybody, who makes any pretensions to be thought worthy of a good share of respectability in society, must have his "Top-Buggy," or an elegant buggy without a top. Hundreds and thousands of young men—and some young ladies also—who possess nothing at all save their clothes, must own a nice top-buggy, which has cost from two to three hundred dollars. And young mechanics and young farmers, who are in debt for almost everything in their possession, must have as nice a top-buggy, or cutter, as the market can afford, whether they are able to afford it or not. This is one feature of the improvements in pleasure-carriages and wheel vehicles of our country.

In the style of a carriage—in the wood-work, ironing, trimming and painting—there seems to be no limit to improvement of a very superior character, not only in carriages for one horse, but in the most elegant carriages for two horses. One cannot go through our cities, nor through the country even, without being impressed with the great truth, that Yankee ingenuity and skill are active in studying out improvements in almost every branch of carriage building. It is true, that some of the improvements in wheel-carriages have been in a retrograde direction; but, for the most part, the improvements are characterized by comfort and security to those who ride in them; by neatness and elegance, which are suggestive of

refinement and respectability in society; and, by the ease of draught and stillness with which they run.

At some future time we may allude to improvements which may yet be made, not only in the style of carriages—the form of some of their different parts—but in their convenience, durability, and easiness of draught.

### WHY WHEELS ARE DISHED.

BY O. E. MILES.

Your correspondent, and my much esteemed friend, Mr. Henry Harper, in his article on page 133 of the Magazine, loses sight of what I have considered as the main and almost only reason for the dish in a carriage-wheel. This article, I observe, is to be continued; but he seems to have done with this branch of his subject, and deduced his conclusions, so that I may be pardoned for replying to this portion of his article, which, if you are so kind as to publish, may result in the enlightenment of some one.

In the first place, Mr. Harper tells us that "it so happens that the strain on a wheel always comes on one particular point, crowding it one particular way; that is, on the bottom side of the wheel, crowding it inward." If he had said the crowding is done by the axle against the hub of the wheel forcing it outwards, his premises would have been correct, and he would have been led to some more correct conclusions. The resistance of the ground against the lower edge of the wheel causes the axle to act as a lever upon the hub of the wheel—the ground acting as a fulcrum—and when the force is great enough to break the wheel, the breaking is done by the spokes in the upper side of the wheel being forced inward till they are torn out of the hub, which, by this time, rests on the ground, as may be seen in Figure 1.

Now, the question occurs to us: Has the dish of this wheel protected it in the least against this disaster? If it has, "I don't see it." In fact, it seems clear to me that the dish has had the effect to accelerate, rather than hinder, the natural tendency of the axle to tear the spokes above the center, backwards, out of the wheel. If the resistance to this forcing outward of the hub were offered to the whole rim simultaneously, instead, as it invariably is to the lower edge only, it would have, as Mr. Harper says, only a tendency to stretch the tire, or force the

spokes endwise into the hub. In fact, it would have the same effect that pressure would upon any other arch; but we have seen that the case is very different.

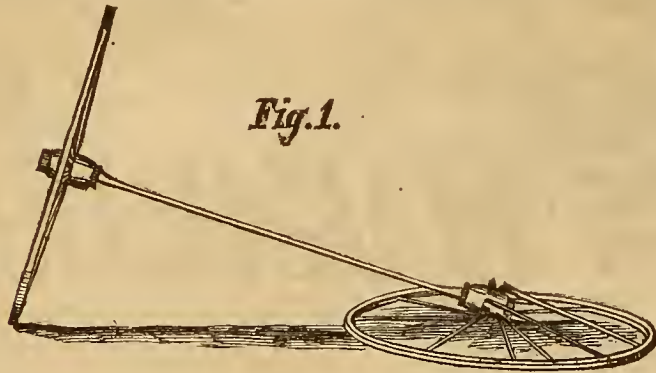

Fig. 1.

Now, what are wheels dished for? I apprehend the main advantages of dish to be, that the spokes may have an elasticity which they could not have if driven straight. As timber has no considerable elasticity endwise, we must, in order to secure this property, give them a little inclination in some direction, and, as inclining them outward gives other advantages which Mr. Harper properly points out, we incline them outward when we make the wheels, first enough to secure the certainty of their all springing in this direction. When all parts of the wheel are well driven together, we leave the rim open just enough to insure a sufficient spring to the spokes, by the time the rim is brought to a perfect joint by the tire. Just enough of this forward spring to the spokes is a nice point to attain, and indispensable to the strength and durability of the wheel. Too much and none at all are equally ruinous. Now, suppose a wheel is made with the spokes tapered equally on both sides, and driven straight at right angles with the axis of the wheel, and the tire set upon it just tight enough to bring the joints well together, without crippling the spokes, I claim that a wheel so constructed while new, and before the vicissitudes of the weather overtake it, will stand more, for all the purposes of a carriage wheel, than a wheel with any degree of dish.

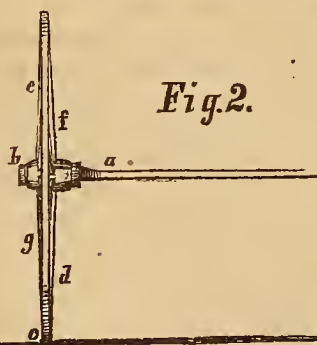

Fig. 2.

The force is applied at *a*, in the direction of *b*. The resistance being at *c*, the wheel receives the strain in the shape of a leverage downwards upon the inner side of *d*, and upward upon the outside of *e*, producing a stretching force upon the tire at the lower and upper edges of the wheel. In this case the tire is a real support against this strain upon the wheel. Now, remove the outer edges of the spokes *e* and *g*, and we have a dished wheel. Apply the force at *a*, as before, and the leverage is downwards upon *d*, but, *e* being gone, the upward force of the front end of the hub is spent upon *f*, which, instead of stretching the tire, as was done at *e*, moves it out from under the tire, thus relieving the tire of its duty, and if force enough is applied to overcome the tenons of the spokes, the wheel is next heard from in the position of Figure 1.

But let a hot day expand the tire upon these two wheels, at the same time shrinking the timber, and mark the difference. The dished wheel, being elastic, expands

with the tire, thus still retaining its support, which the straight wheel refuses to do, and the consequences are obvious. I am, therefore, led to the same conclusion that my friend Harper is, but from different reasons.

## EFFECTS OF WHEEL-CARRIAGES ON ROADS AND HORSES.

### CHAPTER VI.

1. Comparative Effect on the Horses, by the use of Carriages of Two Wheels, of Four Wheels, of Six Wheels, and of Eight Wheels, all carrying the same gross weight; illustrated by a Table. 2. Fore-wheels the Pioneers of the hinder-wheels. 3. The Roads *doubly* interested in the question of Heavy or Light Pressure.

I WILL NOW proceed to state the practical difference to the horses in the use of carriages of two wheels, of four wheels, of six wheels, and of eight wheels, each carrying thirty hundred net weight. I will not suppose any difference in the weights of the respective carriages, because, as the number of wheels increases, the height, the strength, and weight of each wheel would be proportionally reduced. Eighteen hundred is about the weight of a strong cart; it is also the weight of a light wagon—nay, heavier than one of my own, which carries from two to three tons. It is also the weight of a strong stage-coach, licensed to carry six inside and twelve outside passengers, the *average* gross weight of which, when loaded, may be taken at forty-eight hundred-weight, although they are sometimes heavier. However, for the sake of calculation, I will suppose a set of loaded carriages, each of the weight of forty-eight hundred-weight.

*A Table showing the power in weights descending over a pulley, equal to the resistance of one wheel of a carriage of several different constructions, when opposed by an object three inches high, and when opposed by an object an inch and a half high; the carriage in every case to be forty-eight hundred-weight, gross weight.*

	Height of Wheels.	Weight with which each Wheel presses the road.	Weight equal to the resistance of one Wheel when opposed by an object three inches high.	Weight equal to the resistance of one Wheel when opposed by an object half an inch high.
A Carriage with two wheels,	ft. in.	wt.	lb.	lb.
A four-wheel Coach, as at present constructed:	4 8	24	1355	916
The fore-wheel.....	3 4	12	833	552
The hind-wheel.....	4 8	12	677½	458
Six-wheel Carriage, all the wheels of the same height,	3 4	8	555	368
Eight-wheel Carriage, all the wheels of the same height;	2 8	6	482	313

2. Wishing to clear objections as I go, it may be proper to remark, that the fore-wheel is the pioneer of the hinder wheel. If it meets a stone, it either breaks it down in some degree, or pushes it aside; or if it be heavy dirt, it clears the way; whereby the hind-wheels have rarely much resistance of this kind, if the wheels follow well. It is fifty to one if the hind-wheel meets the same obstruction, under precisely the same circumstances, as the fore-wheel did, excepting only on hard pavements, and even these reduced obstructions are to be encountered at renewed efforts, as before explained. The coach-makers accordingly find the fore-wheels of coaches wear out faster than the hinder ones.

Taking the above table to be correct, I think there can

be but one conclusion drawn from it, viz., that carriages, bearing the *same weight*, may be drawn with greater ease in proportion as the number of wheels is increased. In the case of the coach, for instance, the fore-wheel of a common stage-coach requires a power to draw it over an obstruction, whether high or low, compared with the power necessary to draw the fore-wheel of an eight-wheel coach of only two feet eight inches high, each coach carrying the same weight, as seven is to four.

As the very principle on which my reasoning is to "divide and conquer," that is to say, as any given power will overcome a *much greater weight*, when that weight is divided, than when it is entire—it is almost superfluous to admit that the sum of the powers required to draw four wheels of an eight-wheel coach, over an obstruction in succession, is greater than the sum of the powers required to draw the fore and hind-wheels of a coach, as at present constructed, each coach weighing forty-eight hundred-weight; the former requiring, for a three-inch obstruction, 1,928 pounds, and the latter requiring only 1,510 pounds. I will take a fourth of these weights, to reduce them within the power of a man; that will give, on account of the four wheels of an eight-wheel coach, four several weights of 120 pounds each; and, on account of the two wheels of a four-wheel coach, the two several weights of 208 pounds and 169 pounds. Now, by how much a man could lift 120 pounds, four times in succession, more easily than he could lift the two several weights of 208 pounds and 169 pounds once each, in succession—by so much could the horses draw the eight-wheel coach more easily than they could draw the four-wheel coach, over such obstruction.

The force of this reasoning must, I think, be obvious to every person conversant with such matters; it applies to labor of every kind. A man can dig a much greater quantity of ground in a day with a spade *below* his strength, than he can with one equal to his strength. Two men at a crane can lift a much greater quantity of goods to a given height, in the course of a day, in such proportions as they can lift with ease at each time, than they can if the crane be so loaded as to oblige them to exert their strength to the utmost. And, I think, it must be equally obvious, that four horses, drawing an eight-wheel coach with wheels two feet eight inches high, can apply a power equal to 482 pounds four times, in drawing such coach over an obstruction three inches high, with much less labor than that which they must exert in two efforts equal to the several weights of 833 pounds and 677½ pounds, in drawing the wheels of a four-wheel coach, as at present constructed, over a similar object; notwithstanding the amount of the power in the four efforts in the former case exceeds that of the two efforts in the latter case.

3. As the foregoing calculations concern the roads, the consideration is, in my opinion, of high national importance; for it must be kept in mind that the respective powers, as set down in this last table, as necessary to draw any wheel over an obstruction, are actually exerted. The *road itself* is the fulcrum, and the horses' limbs are the levers. The road itself is acted against by the horses' shoes, in proportion to the pressure and grinding property of the wheel; and this takes place all the way down, from the heavy wagon, with its drug-mill wheels, to the light gig. It is ROAD against ROAD, action and reaction being, in every case, *exactly equal*. Therefore, the road must ever be considered as *doubly* interested in this important question.

## CHAPTER VII.

1. Tolls should be imposed on wheels only, without regard to the number of horses drawing any carriage.
2. A liberal number of horses to any carriage, advantageous to the road.
3. Eight-wheel carriages to weigh forty-eight hundred-weight, gross, ought to be encouraged by low tolls, as most advantageous to the proprietors and to the roads.
4. If intensity of pressure on each wheel be removed, the form or width of the wheel is of little consequence.
5. Cylindrical wheels preferable, even for the lightest weights.

1. It is a maxim with me, that sound practice must accord with sound theory. Now if it be admitted that the theory I have attempted to establish be correct, and that, as far as practice can be brought in confirmation of it, I have shown that the division of weight on a number of wheels is practically best, both for the horses and for the roads; it follows that the principles on which our [English] turnpike acts are founded, as far as they tend to encourage the use of carriages of one description, and to discourage those of another, are entirely erroneous. I conceive that the tolls should be imposed on the *wheels* only, without regard to the number of horses; because, upon the principle before-mentioned, that action and reaction are equal; the quantity of power actually used or expended, to draw any particular carriage, can only be equal to the resistance of that carriage.

2. If an extra number of horses be applied to a broad-wheel wagon, the owner is liable to be fined. Suppose eight horses to be the limited number: in going up-hill they are, perhaps, obliged to exert themselves to the utmost to draw the load after them; but if sixteen horses were used in ascending this hill, still no more power would be applied *to the wagon*; each horse would then exert himself only half as much as in the case of the eight horses; and, consequently, the strain of the horses' feet against the ground, at one point, would be only half so much. But, upon the principle I have before urged respecting the division of power, the injury done to the roads from this cause would not, perhaps, be one-twentieth part so much as in the case of only eight horses.

3. I consider that an eight-wheel coach, carrying gross weight, would run easier to the horses, in a very great degree, than a four-wheel coach of the same weight. I consider, also, that an eight-wheel wagon, to weigh itself sixteen hundred-weight, carrying thirty-two hundred-weight of goods, might be easily drawn by two ordinary cart-horses, at the usual rate of road-wagons; four-wheel wagons, carrying several hundred-weights more than half that weight being now drawn by one horse; that such a carriage might be driven by a man on the box; and that it would answer all the purposes of the public carriers, it being several hundred-weight per horse, more than they usually draw. That carriages of this description, with springs, might also be used by the public carriers, with four light horses, at the rate of six miles an hour. That, by the introduction of such carriages, the traveler would be relieved from one of the greatest annoyances he has to encounter, viz.: the gothic, broad-wheel wagon. That, therefore, carriages bearing on the road at the rate of six hundred-weight per wheel, should pass at the lowest rate of toll; and that on wheels above that weight, the tolls should be increased.

4. We need not then trouble ourselves about the shape or breadth of wheels. If we get rid of heavy pressure, we gain a great point. Even a drug-mill cannot grind unless it be heavy. And it happens that, the narrower the wheel the less is the *twist*; consequently, wheels that are both light and narrow cannot do much mischief.

5. Nevertheless, I mean not to plead for *dishing* wheels, however small they may be, or, however lightly they may press on the roads; it being shown before, that upright, cylindrical wheels, whether wide or narrow, with axles perfectly straight, and with cylindrical ends, being the *only* form that has a natural tendency to roll straight forwards, should *always* be used; as they must, under *every circumstance*, be less injurious to the roads, and, in that degree, must cause less labor to the horses than wheels of any other form.

CHAPTER VIII.

1. Principle on which Tolls ought to be imposed. 2. How a Table of Tolls ought to be calculated to meet this principle. 3. A Table of Tolls calculated on this principle. 4. Operation of tolls so calculated. Opinion of JOHN LOUDEN McADAM. 5. Opinion of the Legislature, in 13th Geo. III., on the injury caused by excessive weights. Sixteen inch rollers as now constructed, liable to an additional toll of *forty pounds*. 6. Breadth of wheels no security against the destructive effect of pressure, further shown. 7. Probable reasons why heavy wagons were formerly encouraged. 8. Wheels of light pressure more urgently necessary where the materials for roads are of a soft and bad quality.

1. IN suggesting the adoption of a new principle on which to levy tolls on carriages, it is proper that I should explain the reasons for which I venture to suggest it.

A turnpike-road is proposed to be made; and, in order to purchase the necessary lands, and to procure labor and materials to carry the work into effect, funds must be obtained; for which purpose, money is borrowed; and the tolls to be collected are pledged to the lenders, to pay not only the interest, but, by degrees, the principal also. The tolls, therefore, ought to be levied on every carriage at such a rate as will repair the damage done by such carriage in traveling over it; and a further additional sum towards the interest and principal of the borrowed money, and no more. It ought not, therefore, in my opinion, to be taken into account with what the carriage is loaded, that is to say, whether it be loaded with human beings, or with manure, or with any kind of merchandise—whether it be a cart, or a gig, a coach or a wagon. The only consideration ought to be how much money will it require to repair the damage done by such vehicle to the road, together with a reasonable sum for other purposes. This, as I have before stated, is to be estimated only by the number of the wheels and the weight with which they respectively press the road, without any regard whatever to the number of horses drawing such carriage.

It is time that the principle and also the practice of favoring one species of commerce at the expense of another were entirely laid aside. But, to be consistent, if we suffer manure to pass toll-free, in order that the *necessaries of life* may be rendered at a low price, we ought also to grant the same indulgence to live cattle; to butchers' carts; to millers' carts and wagons; to farmers' carts and wagons, carrying corn, potatoes, turnips, carrots and cabbages; to the thousands of market carts, with butter, eggs, veal, pork, poultry, &c.; to bakers' carts; to brewers' drays; to carts and wagons loaded with coals and other fuel; to carriages loaded with wool or flax, raw and manufactured. And, as houses to live in are also *necessaries of life*, we ought to exempt building-materials of all descriptions, viz.: stones, bricks, tiles, lime, sand, and timber.

2. In making out a table of tolls, it ought, upon the principle I have laid down, so to be calculated, as much as possible, the greatest division of weight; so that it should never be the interest of the owner of any carriage

to lessen his number of wheels: that is to say, that any given weight should always pay less toll on eight wheels than on four wheels, and less toll on six wheels than on four, and less toll on four wheels than on two wheels.

3. A table of tolls, calculated in the following proportions, would effect this object, viz.:

For every pair of wheels bearing on the ground with a weight not exceeding.....	Weight in cwts.	Increased toll.		Total toll.	
		l.	s. d.	l.	s. d.
do do	12	0	0 0	0	0 2
do do	14	0	0 0½	0	0 2½
do do	16	0	0 1	0	0 3½
do do	18	0	0 1½	0	0 5
do do	20	0	0 2	0	0 7
do do	22	0	0 3	0	0 10
do do	24	0	0 4	0	1 2
do do	26	0	0 5	0	1 7
do do	28	0	0 6	0	2 1
do do	30	0	0 7	0	2 8
do do	32	0	0 8	0	3 4
do do	34	0	0 9	0	4 1
do do	36	0	0 10	0	4 11
do do	38	0	0 10	0	5 10
do do	40	1	0	0	6 10
do do	42	1	1	0	7 11
do do	44	1	2	0	9 1
do do	46	1	3	0	10 4
do do	48	1	4	0	11 8
do do	50	1	5	0	13 1
do do	52	1	6	0	14 7
do do	54	1	7	0	16 2
do do	56	1	8	0	17 10
do do	58	1	9	0	19 7
do do	60	1	10	1	1 5
do do	62	1	11	1	3 4
do do	64	2	0	1	5 4
do do	66	2	1	1	7 5
do do	68	2	2	1	9 7
do do	70	2	3	1	11 10
do do	72	2	4	1	14 2
do do	74	2	5	1	16 7
do do	76	2	6	1	19 1
do do	78	2	7	2	1 8
do do	80	2	8	2	4 4

Excepting only when a load consists of one undivided mass: as a block of stone, one single piece of iron-work, one piece of timber, or the like; in which case, it should be allowed to pass at a certain moderate toll, say at thirty hundred-weight per pair of wheels.

4. The reader will see that, by the above table, eight-wheel carriages might pass with very heavy loads, at a very moderate toll: even four tons might pass for *2s. 4d.*; while a four-wheel wagon, weighing eight tons, would pay *4l. 8s. 8d.* My friend, John Louden McAdam,\* the General Surveyor of the Bristol turnpike-roads, gives me, as his opinion, that the only wagon of this description which travels between London and Bristol does more injury to the roads than *all the other carriages* on the road put together, distance for distance. If this opinion be correct, and I have no doubt but it is, such toll would be but fairly and moderately imposed.

5. It is plain that in the 13th year of George III., the Legislature were aware of the great injury sustained by excessive weights, by their imposing an additional toll of *twenty shillings per hundred-weight* on all over-weights; but they were not aware that the injury regularly increased in an increasing ratio, from the lowest weights to

\* This gentleman is the well-known promoter of the new system of constructing roads, which may be considered as the commencement of a new era in this important branch of science.



the highest; or it does not seem that they knew how to meet the evil. It is on this last-mentioned principle that the above table of tolls proceeds.

Besides, as sixteen-inch rollers, contrary to the express letter of the statute, do not bear with their whole breadth on the road, we have a right to consider eight tons, as carried on nine-inch wheels; we shall then find the over-weight to amount to two tons, which, at twenty shillings per hundred-weight, would be *forty pounds!* which is the toll *really intended* by the Legislature to be imposed; and which, according to the true intent and meaning, as well as the letter of the statute, they are liable to pay.

6. I have said (Chap. iv., § 6): "The present system of broad wheels I consider a system of mere mockery," of which opinion the above-stated fact is an abundant confirmation. In short, if the law were *literally* obeyed, if wheels were made *perfectly conical*, bearing with their *whole breadth* on the surface of the road, the injury caused to the roads would be ten times greater than it now is from the action of those wheels; because the dragging backward and forward, or *twist*, would be incomparably greater at the sides of each wheel than at the middle of the rim; whereas, by the present construction, the edges of the rim do not touch the road. (See chap. ii., § 1, *et. seq.*) The injury to the roads would also be increased tenfold, from the increased labor of the horses in drawing carriages with wheels so constructed. The fact is, that **NO WHEEL**, generally speaking, whether it be six inches wide, or nine inches wide, or sixteen inches wide, does on a flat and even surface *more than about three inches*. Therefore, whether the law as it now stands be strictly enforced, or whether, as at present, it be universally evaded, it must be evident that breadth of rim in either case can be no security against the destructive effects of pressure. When we consider the state of the roads throughout England forty or fifty years ago, it is not wonderful that the Legislature should have encouraged the use of heavy broad-wheel wagons by low tolls, and even by a total exemption from tolls; the motive for which evidently was to break down the large stones which at that time were thrown upon them, as well as to press in the sides of the deep ruts which everywhere abounded; and that these were the objects, especially the latter, it is further evident, by their permitting wagons with nine-inch wheels, so adjusted as to roll a surface of sixteen inches on each side, to pass at reduced tolls. But it is difficult to assign any reason why the fixed maximum weight of these favored vehicles at eight tons, imposing on them the enormous fine of twenty shillings per hundred-weight, from eight tons upwards.

8. I am aware that it will be objected, by persons resident in districts where the materials for roads are of a soft and bad quality, and where the roads are consequently deep and rutty, that the light wheels I propose would be buried in the ruts, and that such wheels could therefore never be used. To such I would state what I conceive to be a parallel case: Suppose a farmer to have a tender meadow, and he were to turn in heavy oxen, the consequence would be that these oxen would break the turf at every step, and tread it perhaps six or eight inches deep; whereas, if this meadow were grazed with sheep, the surface of the meadow would be uninjured. Now it should be remembered that the hoof of the ox as much exceeds that of the sheep, as the weight of the former does that of the latter; but, as in the case of the heavy wheel,

it is the intensity of pressure in *one mass* which does the mischief; which is by no means compensated by the breadth of the wheel in one case, nor by the size of the hoof in the other. Nor, if the weight of all the sheep in the meadow were equal to that of all the oxen, would the damage done by the former bear any proportion to that done by the latter? Just as I have before stated, the damage done to roads by light wheels would bear no proportion to that done by heavy ones, although, in both cases, the sum of the weights passing over a road might be equal. Therefore, whenever the materials are bad, and the roads liable to become foundrous, it is exactly in that proportion *more and more important* that wheels of light pressure should be used. As in the case of the meadow, the softer it is the lighter should be the tread of the animals with which it is depastured. The fact is, that if wheels of light pressure only were used on such roads, it is not likely that deep ruts would ever be formed.

### CARRIAGE WHEELS—THEIR MECHANICAL CONSTRUCTION AND USE CONSIDERED.

BY HENRY HARPER.

(Continued from page 147.)

**AXLE BOXES AND SETTING AXLES.**—If we look back fifty years, and compare the art of carriage-building with its present state, we have reason for congratulating ourselves upon the advances that have been made, although these advances have been slow in comparison with what they will be (with our present facilities), fifty years hence. If we compare what was said by one who was in advance of his time in the art of carriage-building sixty years ago, with what is practiced by one who is perhaps equally in advance of his time at the present day, we can realize something of the march of improvements. In an article published by Mr. Fry, fifty years ago, and lately re-published in this Magazine, he says: "I have a light wagon about seventeen hundred-weight, with turned axle and brass boxes bored to fit them, which requires about an ounce of oil at a time—more would be wasted. With this wagon, two horses constantly fetch forty-eight bushels of coals from the pit—at least two tons." Remember this was on English roads at a time that they were in advance of what they ever have been on this continent.

I have a neighbor, Mr. S. D. White, of Berlin, Wis., and, although he is not a practical mechanic, yet he has got up a wagon for his own use which we want to compare with Mr. Fry's wagon. Mr. White's wagon weighs 800 pounds, and is used with one horse—a good substantial one—but probably not as good as the English draught horses; for then, as now, they take special pains in rearing them, which we do not. Mr. White hauls on his wagon from 4,500 to 4,800 pounds by actual weight, when the roads are in a good condition. His wagon has been in constant use for over five years, using the same horse, which shows not the least sign of overtaxed labor. Admitting he has used his wagon 1,500 days, and drove it twenty-five miles per day, it has now been driven 37,500 miles. One set of tire has been worn out and replaced with new. The paint has been worn off and replaced; further, this wagon shows but little signs of wear.

Those who have seen axles fail on light wagons and carriages before the other parts are worn out, will be

surprised to know how these axles wear. They are called the cheap kind of axles, made with a plain taper, and without any attempt at getting up anything cute, as is often done. The axle-boxes are cast with bearings at each end in the usual way. The ends of the axle-boxes are secured in a simple and effectual way against sand. The wear which this 37,500 miles has made on the axle-boxes and axle-arms is not perceptible except in a very slight shortening in the length of the boxes; so far, they are just as good as when new.

As we have said, Mr. White is rather in advance of the craft, and has secured a competence that would last him some time, simply by the use of this wagon; but this is not a drop in the great ocean of good that may be derived by the world if his improvement is rightly appreciated and studied by the craft. Many such things are lost to the world for the want of some one who interests himself enough to study philosophic principles, and who appreciates them. Much has been lost by not having an organ wherein such developments can be recorded and urged on the minds of those interested. In this case, it is certain Mr. White has gone as far ahead of the present art of constructing wagons for certain purposes, as we are of Mr. Fry's time.

The size of the axle-box in the wheel is the subject that we propose to discuss here. There seems to be a variety of opinions on this subject; and what is more strange, those who advocate these various opinions seem to have good practical reasons for their different opinions. A question is often asked in agricultural papers, and by individuals all over the world, "Which is the easiest draught—the large or small axles?" The answers are various, and all seem to be founded on good evidence, that is, practical tests. There is no doubt but a certain man has had a wooden-axled wagon, that runs easier than any iron axle that he ever used. The same may be said of another man who has used an iron-axle wagon. Although there are various answers given, it is certain the question has but one true answer, and yet this question is as unsettled by the craft as by other people.

If the mathematician should find serious difficulty in solving the problem whether it would make a larger sum greater or less, to add a small sum to it, it would show that his mathematical science was on a par with the mechanical science of the craft; especially that part who cannot appreciate the benefit to be derived from the publication of periodical literature pertaining to the craft. If we do not understand the mechanical power of the wheel, and in what way it operates, the most plain and simple question will be a mystery,—the same as the mathematical question alluded to would be to the child.

The wagon and carriage-making mechanism—as would appear from the various opinions on the subject under consideration—when compared with mathematical science, is merely in its infancy; not knowing good from evil. Being so, how absurd it is that we do not avail ourselves of mathematical science when it can be applied with so much usefulness? As has been said and illustrated before—on page 114, and other places in this Magazine—wagon wheels are purely levers. The fulcrum of this lever is always made by the obstacle which the rim of the wheel rests upon as it passes over it. It is not always the case that the wheel is lifted up over the fulcrum, as it would be by a stone, block of wood, or any such hard substance; often the rim of the wheel crushes down the fulcrum level

with the path, as in cases of sand, mud, &c. But if it is to lift the wheel over the obstacle, or to crush the obstacle down, or to ascend an incline plane, no matter what use the wheel is applied to, it is a lever, and it is well known that to increase the leverage is to increase the power; yet with a wagon there are other considerations to be taken into account, as we shall see.

There are three ways to increase leverage in wagon wheels. One is to enlarge the wheel. It can be done to only a certain extent with advantage. If it is enlarged beyond a certain extent—so as to raise the draught line back from the horses too high—it gives to the wagon a lever power, which neutralizes the lever that the horses apply to the wagon.

The second way is to raise the line of draught towards the horses, so that it will be on an average 90° from the obstacle or fulcrum. This way also has its objection, because it can only be done by lowering the wheels. The medium point to be gained by the above two ways is generally disregarded and thrown away, by fancifully bending the pole, or other ways of unnecessarily raising the draught.

The third way for increasing the leverage, is to diminish the size of the axle-box. There is no counteracting influence to this gain; but it will always be a gain, so long as we can maintain sufficient strength for the axle-arm. If we can make improvements in iron, so that a less amount will sustain a greater load, we are sure of two substantial gains by it. First, the lessening of the height of the axle is an actual gain of over \$4 to every pound lessened. Second, the amount of leverage gained will amount to over \$100 for every pound of draught that is gained on 1,000 lbs. weight of the load. It will be seen that what we are too apt to regard as trifles, often determine whether a wagon or carriage is worth the price paid for it, or nothing. The polish and graceful appearance which we are so apt to urge on people's consideration sinks to a secondary item, in comparison. When defects in reasoning are fraught with such serious consequences, is it not a shame that we should have such a variety of opinions in regard to a plain and simple truth?

But, says one, if it is so plain and sensible, why do not practical tests made by mechanics settle the question? You admit that some have had wooden axled wagons that they thought, and probably found, run easier than iron axles. It would be strange if it was not so, considering the various opinions and practices existing about setting axles; considering also that there is but one mechanical law for the various opinions and practices to be based upon. Mr. Fairbanks, Mr. Howe, and all other great scale makers shape their instruments for determining weights, in reference to one mechanical law. The result is, they determine weights with almost mathematical accuracy. They avail themselves of mathematical principles which they know will not fail them.

If wagon and carriage-makers would observe the same universal mechanical law, and apply it mathematically, the results would be uniform and satisfactory, as in the case of scales of different manufacturers. Both are lever powers; but in the case of the wagon, the fact is not comprehended so readily by the craft as it is by the scale-makers.

On page 51, Vol. V., of this Magazine, we have directions given for setting axles, which, the writer says, are good; the reasons for which, he says he *can* mathemati-

cally explain, but does not think it necessary. The mathematical proofs and explanations I attach more importance to than he does, and have taken some pains to test it by them, so far as the effect would be on what is called the "gather" to wheels.

If the angles to the sides of the axle-box, called the taper, were in proportion one inch to the foot, as they generally are on wooden axles, the gather which he proposes as a rule to be governed by, would make wagon wheels *run sideway* 73 feet 4 inches to every mile that the wagon was drawn forwards.

That much power is expended in every mile traveled, for no useful purpose whatever. If we could tell the exact amount of power that it would take to draw the wagon and load sideways 73 feet 4 inches, then we could tell how much power would be wasted on such a wagon to every mile's forward movement that it made. The power is not all expended at one time; but it does not make the power any less wasted, because the waste is equally distributed on every movement of the wagon's going one mile. Mathematics shows the amount of waste when it is all collected together. When we have got it for one mile, the same science will sum up the sum total that will be wasted on the worthless wagon before it is worn out; but when it is all collected together and shown to the man, who cannot comprehend the accuracy of the principle, it will be so great, that he will be more bewildered than inclined to realize it. The rules that he lays down are not peculiarly his own; thousands of wagon and carriage-makers approve and practice the same thing in some other way perhaps; but the consequences are equally bad.

There is another class who are on the increase, and who say that the easiest way that wheels can run is to incline them to run in parallel lines. Now, when we apply geometrical and mathematical rules to the first, it discloses the fact that there is a sideways movement to a wagon wheel in addition to the forward one. The same rules show that the other way, which a proportion of mechanics adopt, gives the wheels but one movement, and that is directly forward. Then the conclusion must be that the later is the easiest movement. It will be seen that it is dangerous to call on any of the positive sciences to prove a fallacy, as it does in this case.

Another difficulty in the way of making the test accurate between large and small axles by former experiment is, the different ways of making the bearings on the shoulder and the point of the axle. Where certain geometrical rules and calculations are made and applied to the set of an axle, so that the bearing are equal on the two extremes of the axle, and it is kept properly lubricated, it is very doubtful whether the wood-work of two or three wagons will last long enough to wear out one set of iron axles. At least Mr. White's wagon, which we have referred to, does not indicate anything to the contrary. If we examine ten thousand wagons, we shall not be likely to find one that has had an equal amount of wear on the axles, without showing more signs of wear than this wagon. Nor would we be likely to find another wagon that the same amount of load could be moved on, as easy as on this wagon.

We may search in vain for any other cause of the extraordinary wear of the axles than the equal bearing on the extremities of the axle-arms. By the application of strict geometrical rules in accordance with natural laws there would not be a deviation of one axle, from the same

result, in ten thousand. But, says one, we cannot be expected to apply the science of geometry to setting axles; it requires too much study for a mechanic to master the science so as to make an application in this way. This is a mistake. In this age of progression, instruments are made so that the most uneducated mechanic can apply geometry to setting axles in a way that would puzzle the most profound geometrician. Why do not mechanics avail themselves of it? They do in many cases; but in a great many other cases they cannot comprehend the importance of the subject, any more than they can comprehend the absurdity of making the wheels of a wagon run sideways.

## Home Circle.

### THE DESERTER;

A STORY OF THE MEXICAN WAR.

BY JAMES SCOTT.

(Concluded from page 153.)

THE train was to return in a few days, and it was thought prudent for part of our force to hold the pass during the interval, lest the enemy should again take it into their heads to occupy it. This duty fell upon our company and a detachment of riflemen; the latter were posted in the rude redoubt we had stormed, and a cluster of dilapidated huts, probably erected by wood-cutters, were selected as our quarters. It was not long ere we discovered that our residence in that wild glen was not to be a quiet or a dull one; for while a party of men were digging graves to receive the bodies of the Captain and four of our comrades who had fallen in the fight, several shots were heard, and one of the diggers dropped his spade with a howl of pain—a ball had shattered his arm. Wreaths of blue, vapory smoke away up among the crags, told from whence the firing came, and we soon had more of it. The guerrillas had rallied, and those shots were but the commencement of a scattering fight that continued for two days, with but little damage on either side, for the action of the first day had taught the foe that close quarters were dangerous, and they preserved a safe distance. But there was one exception—one man who ventured boldly and aimed with deadly accuracy—we *knew him*—and hundreds of leaden pellets sought his body, only to fall flattened from the rocks—the man was lucky!

It was dark, when, completely exhausted by fatigue, I sought, in a corner of one of the huts, the rest nature so much needed; but my eyes were hardly closed, when a heavy hand was laid on my breast, and a voice whispered:

"Wake up, Bob, an' come out here a minnit, I've somethin' to tell yer!"

The voice was that of Joe Read, a wild, devil-may-care sort of fellow from Missouri; and knowing the man was constitutionally lazy, I concluded that when *he*, of all others, was astir and armed, there must be something of importance going on, so I arose and followed him outside of the building.

"Bob," said Joe, when we reached the open air, "how'd yer like to tap the Dutchman?"

"Tap the Dutchman!" what do you mean, I inquired.

"Why Carl—the lop-ear wot shot the Captain, how'd yer like to wipe him out—plug him, yer know."

"Like it! I have to-day fired at the villain until my musket became foul, and the barrel was burning hot—but explain; what does all this mean?"

"I'll tell you," answered my companion in a low, impressive voice. "The Ditcher war in a mighty good place to-day, worn't he? None on us could hit his blasted carkass, an' yet *he* made out to bore Bill Jones's shoulder through an' through, 'sides barkin' that Irish fellar's leg, an' 'skeerin' Todd half to death by tearin' his trousers with a slug; now, don't yer reckon that Dutchman 'll be in the same spot at daylight in the mornin'?"

"Nothing more likely," I said; "for he is well aware that we can't reach him from the gorge here; the cliff can't be scaled at this point, nor can any party leave the pass in order to get behind, or above him, without being observed from his lofty position. Now tell me what you are driving at?"

"Well, yer see, while I wor a dodging 'round 'mong the bushes an' boulders, tryin' to git a sight at the Dutch fellar up yonder, I come to a open place in the cliff on tother side of the pass from whar he wor a firin', it wor a sort of gutter, like, cut deep inter the rock by the water runnin' down when it rains. Wall, when I seed that openin', thinks I to myself, if I cud clime up through thar to the top of the cliff, I cud fotch the dirty skunk like a mice. An' the best of it wor, if I cud clime at all, I cud do it 'thout bein' seed arter I got inter the hole; so, says I, here goes, an' in I went, an' I clum, an' clum, an' clum, and arter a long while, I'm whipped if I *did'nt* come out at the top. Then says I, to myself, the Ditcher's my meat sartin, an' I poked my head outer the hole, an' I declare, I never wor so mad in all my born days, for thar he wor a walkin' off with his gun over his shoulder as cool as a icicle; he wor too fur to shute at, so I sot down an' grumbled a streak. It wor a gittin' dark, an' I spose he wor a goin' to grub, for I seed smoke a risin' from a holler place 'way up the mountain whar the greasers are a campin' I reckon. Wall, I got up and jawed a little more, and then I clum down again. An' when I got down, says I to myself, he'll be back again in the mornin', an' dogged if I won't be up thar to receive him. Wall, arter a while, I thinks, sposin' I shud miss him the fust fire, for it's a tolable long shot across the gorge, won't he git up an' leave thar quicker; an' then, says I to myself, Bob Barry's a fust rate shot, an' I'll git him to go 'long with me, an' if we can't do for him 'tween us, why let the varmint slide; so I went an' woke you up; an' now what do yer say?"

"I'll go of course," I replied; "but can we climb up there in the dark?"

"Sartin we kin if we're keerful," said Joe; "the way are easy 'nuff arter yer knows whar it is. We'd better start in a couple of hours from now, so we can be up thar at daylight."

When the gray light of day first peeped over the mountain, we had gained the place of ambush, where we waited impatiently for the rising of the sun, and the appearance of the renegade. As soon as there was sufficient light to see objects at a distance, we commenced a sharp look-out for the enemy. They soon appeared, to the number of thirty or forty, issuing from a defile in the breast of the mountain, where they had no doubt spent the night. After a short halt, probably for consultation, they broke into parties of two and three, and scattered off

in search of available points from which to fire on our men without exposing their own precious hides. All this we saw, but our whole attention was riveted on a stalwart form that strode with quick determined steps towards the brink of the opposite cliff. The Mexican *scrape* of brilliant pattern that draped the figure—the wide-brimmed, velvet-banded *sombrero* that covered the head and shaded the face, and the gay ranchero pantaloons, glittering with scores of silver buttons, did not, for one instant, deceive us as to the identity of the wearer—it was Carl Brenner. My heart beat quickly, painfully, as he neared the edge of the chasm, and the eyes of my comrade glittered like those of the deadly Cobra, while his lips were drawn into a wicked grin that exposed the white clenched teeth. Simultaneously, we ran the barrels of our muskets cautiously out over the ledge behind which we knelt, and—waited. I wonder if no thought of death flashed through that man's brain, as he halted, and grasping a projecting point of rock, leaned out over the precipice and peered down into the camp. I think not; although, even then, the death angel was very, very near him. There might have been death in his thoughts, but not his own, for as my eye rested on his face over the "sight," on my weapon, I could see that he smiled—yes, smiled! The elbow of my companion touched me slightly; it was the signal! Carefully, I ran my eye along the barrel, my finger pressed the trigger, the report followed, and a whiff of smoke shut him out of view. I sprang to my feet—he was drawn up to his full height; one hand was pressed tightly to his forehead, and that hand was turning red—a deep, dark red; another report by my side, another whiff of smoke, and the form on the cliff bent over nearly double, straightened up again with a spasmodic jerk, reeled for an instant like a drunken man, and fell! Our hearts stood still in horror, for the head, shoulders and body projected over the fearful chasm. For a second, the balance was preserved—a shiver, and slowly the head sunk lower—lower—lower—whiz! A dark object shot downward, and Joe Read and I looked into each other's eyes; he was pale as death, and I felt that my face was as bloodless as his.

Neither of us cared to visit the spot where Carl Brenner fell; but, when two days afterwards, we marched out of that mountain pass, I saw a pile of stones surmounted by a rude cross; there were dark blotches on the smooth face of the cliff, to a height of ten feet; I knew their meaning, and turned away with a sigh I could not suppress.

## THE FAIRY CORONATION.

BY MARGARET E. STRONG.

It was midnight—the fair moon shining brightly as she ascended higher in the blue heavens, gilding the distant spires, reflecting her bright lustre in the limpid waters of the murmuring brooklet. Every plain and sequestered dell shared alike her brilliancy. The balmy zephyrs breathed softly through the flowers, gently agitating the leaves, and wafting afar their sweet fragrance.

'Twas the rosy month of June, and at this magic hour, to grace the beauteous dell with their presence, came the tiny spirits of the air, floating gracefully on their downy winglets to the sweet music of the bubbling fountain, and the voice of the summer's breeze. On, on they came dancing lightly 'mid the flowers that decked the Fairy-circle, and waving high their tiny wands, till they reached

the mossy heath by the side of the moon-lit brook. There, arranging themselves on nature's velvet carpet, they proceeded to the important business for which they had been summoned—the appointment of a new sovereign—for the best loved of the elfin sprites was by the rules of their order to succeed their departed Queen. The choice fell on one beloved for her goodness, virtue and fidelity, and who had long been a favorite of the well-remembered sovereign.

Now all was pleasure and mirth among the fairy sisterhood; they waltzing on the leaves of the beautiful flowers and playing all manner of tricks in the sylvan grot. All were impatient to look upon the brow of the favorite, soon to be encircled with a flowery wreath, and to prove their loyalty by a prompt submission to the laws of fairy-land. Night passed on—again the azure sky was lit up by a starry train, and the nightingale sang sweetly in the distant grove. Again came the fairy troop of the fair Titania; some from their flowery beds, beside the murmuring brook, and some from their slumbers among the forest roses, for it was the dawn of the Fairy-day and the time for the coronation. Arrayed in their robes of gossamer, with their wings gently waving in the summer breeze, they hastened forward. Onward they came, flitting over the dewy grass, and gamboling among the wild wood flowers; thronging the moon-lit dell—above, below, on every side—until they reached again the heath by the margin of the moon-lit brook. A happier group than these fairy elves has seldom been seen.

Seating their future Queen on a mossy throne, they crowned her with a chaplet made of the bursting buds of the summer rose, and while her anxious subjects thronged around her to catch the words that fell in silvery strains from her honeyed lips, she thus addressed them:

"You have, my dear subjects, by your own choice, made me your Queen. I need not say how grateful I am for the honor thus conferred upon me, and that I hope hereafter by conduct to merit still the love of those to whom I am indebted for my crown. Peace, prosperity and happiness have hitherto crowned the efforts of *her* who still lives in your memory, and *I* shall endeavor to evince my gratitude for your kindness in thus placing me in the exalted position I now occupy, by endeavoring to discharge, to the extent of my abilities, the duties incumbent upon me as the Fairy Queen; and may I be able to add another ray of lustre to the already glorious halo which encircles the history of this our Fairy Land. I will—but hark! our sentry-elf sounds an alarm; the moon and her starry train are gradually fading from the azure heavens, and in yonder eastern sky the dawn appears; the hill tops glisten in the morning light; the sky-lark shakes his dappled wing and soars higher and higher to the blue vault above, and the early chanticleer warns us to seek our homes among the flowers."

At her warning away sped the Fairy throng, sitting merrily as they hied them to their downy beds in bud or blossom, leaving their monarch to her repose on the bosom of a stately rose that grew beside the throne.

TAXES.—The Washington correspondent of the Worcester *Transcript*, says that tobacco pays a tax of \$2,850,000; leather comes next, paying \$1,900,000; then iron, \$1,700,000; and then malt liquor, \$1,500,000. Peddlers pay \$300,000 for their licenses, and those who ride in carriages, \$250,000.

## Pen Illustrations of the Drafts.

### FOUR-PASSENGER COUPÉ ROCKAWAY.

*Illustrated on Plate XL.*

THE coupé fever having become chronic in this country, is now assuming a *typhus* form in other vehicles. Of the latter kind is our example. It is intended for four passengers, including the driver, and will make a very pretty carriage for the family. Ours is from an entirely original design.

### COAL-SCUTTLE BUGGY.

*Illustrated on Plate XLI.*

WE give this as a new phase in the form of the coal-box buggy, from the pencil of one of our special artists. No doubt it will meet with full as much favor from our patrons, as anything of the kind originating within the past three years. As may be seen, the backs of the body and seat are both round-cornered. The box, back of the seat, is usually left open.

### RIBBED BUGGY.

*Illustrated on Plate XLII.*

THIS design is not given with the idea that we are furnishing anything very novel, nor as being a design very much admired by us; still, it will undoubtedly find favor in the eyes of some individuals. We present it in the hope of satisfying the urgent call we are receiving for a greater variety of buggies than we are accustomed to publish in a single number of this journal. With the remark, that all the ribs—whether on the seat or side panel—are nailed on, we dismiss the subject.

## Sparks from the Anvil.

### MILES' WAGON STAKE.

THE annexed engravings represent a new and improved stake for wagons, for which a patent was granted to O. E. Miles, of Aurora, Ill., October 27, 1863. It is of cast-iron, and so constructed as to combine simplicity and elegance, with great convenience and economy, to both the makers and users of wagons. The inventor informs us, that many sets of these stakes have been in use in this vicinity during the last year, and subjected to tests which place their superior strength beyond question, not one having been reported broken, while they weigh no more than the ordinary wooden stakes with their wrought-iron attachments. Those who use them, also inform him that they would not be deprived of the convenience for many times their cost. It will be seen, by referring to the cut, that the body of the stake, *A*, has a foot, *a á e*, with a recess in its under side, which, when the bolster, *B*, is dressed to the proper thickness, and the end rounded in the usual manner, is very quickly fitted to it. The part of the foot inside the stake, *A*, extending across the bolster, and two

inches in length, is let in so as to be flush on the upper surface, thus forming a rub-iron, as well as to effectually prevent the casting from slipping endwise. The flange, *l*,



drops down all around  $\frac{3}{8}$  of an inch, which also serves to keep the stake in position, as well as to prevent water from getting under the casting. It is securely held down by a clip, *c*, the operation of which is readily seen, and a counter sunk bolt passing down through *a*, having a nut at *d*. These not only bind the stake firmly in a perpendicular position, and afford a ready means of tightening the same in case of shrinkage of the bolster, but afford also a means of replacing one in case of a break, with the greatest facility; the only tool necessary for this purpose being an ordinary wrench. All blacksmiths know what a multitude of pieces are involved in the ironing of ordinary stakes, and what an expensive and troublesome job of repairing it is, to replace a braker on. The wood-workman puts these stakes on as cheaply as he can make wooden ones. The iron stakes, with their fastenings, cost about the same as the material for the others, *thus saving all the labor of ironing*. Besides, it is very evident that a bolster ironed with these stakes, is much more securely protected against splitting and dampness than when ironed in the ordinary manner. When bulky loading, or an extra box requires it, the socket, *f*, furnishes an ever ready means of elongating the stakes to any height desired, by the simple insertion of a round wooden stick. The hole, *h*, furnishes a convenient place to secure a binding rope when one is used.

Fig. 2 represents another style intended for trucks and sleds. The foot and fastenings are the same as the other, with a low, rectangular socket which receives a wooden stake. Orders or letters of inquiry may be addressed to the inventor as above, or to the manufacturers, C. B. Brown & Co., Chicago, Illinois.

## Paint Room.

### BAD LINSEED-OIL AND TURPENTINE.

A CORRESPONDENT of the London *Builder* writes to that journal, saying: My attention has been called to the repeated complaints of your correspondents respecting the adulteration of linseed-oil, turpentine, &c. I beg leave to differ with your correspondent as to the cause altogether resting with the English manufacturer, as he asserts. I, having had some years experience in oils, will, with your permission, endeavor to enlighten your readers as to the several causes of bad oil. In the first place, it is a mistake to think that, by going abroad, we can be sure of pure oil; the very fact of our exporting so much, proves that our oil is preferred by foreigners to their own; and having to compete with foreign adulterated oil, has been one fault of the English crushers not being so particular, as they ought, to crush selected seed. It is well known, that linseed-oil is sold as a mixed seed, varying from five to fifteen per cent. of wild rape and other seeds, which proceeds from the negligence (the mildest term I can use) of the growers in not needing their grounds; and, as the seed passes from buyer to buyer, no doubt it does not improve in quality before reaching the crushers in this country, who have also to contend with other difficulties, such as the seed becoming heated on the voyage (which cannot always be avoided), but which renders the oil extracted from such seed totally unfit for varnish and painting purposes, although sold in the market as good marketable oil. The crushers, too, make every effort to extract the greatest possible quantity of oil from the seed, regardless of quality. I should like to go into full details as to how this is done did space permit, but must leave that to a future time. 2d. An immense competition exists among the dealers, who buy the *marketable* linseed-oils, which term they consider a sufficient guarantee for the quality, not knowing, or caring, perhaps, how it is crushed, their sole object being to buy as cheaply as possible, so as to be able to compete successfully with their neighbors; and the retailer is in precisely the same position.

Being a practical man, this subject has engaged my attention for some years, and induced me to go to considerable trouble to find out the cause and provide a remedy. The cause is the prevalence of fatty matter in the oil. This I can, by a process, entirely remove, and the oil, thus treated, is particularly adapted for the purpose of varnish-making and painting (at the same time being free from all oxyds of lead), consequently can be used for the most delicate tints of color, without in any way injuring them in the working; it also dries with a finer face than ordinary oil.

I will next treat of spirits of turpentine. This is also a most essential article, and one which must be absolutely pure for both varnish-making and painting, and nothing is more easily adulterated, or detected when adulterated. I need not inform your readers, that, previous to the American War, we could always depend upon the American turpentine; but now they are importing French-drawn turpentine from this country, and also from France, so that it is a fallacy to depend on them for *genuine* American turpentine. A few years since, the French turpentine was very inferior. The extreme margin, however, be-

tween the original price of turpentine and the price now, has induced the French to improve their manufacture, till we can now somewhat depend upon some being of a very fair quality.

The introduction of *mineral* (or *petroleum*) spirits from America has, however, opened a wide field for adulteration, the evils of which cannot be too widely known, as I shall proceed to explain. Pure vegetable turpentine, upon exposure to the air, always loses in bulk by evaporation, but gains in weight by absorption of oxygen, which makes it more binding in its properties. This peculiarity, *none* of the *mineral substitutes* possess; on the contrary, the mineral is so extremely volatile that, upon exposure, the spirit *all* flies off, leaving the oil entirely without anything to help to harden it, and consequently increases the evil of the bad oil, instead of counteracting it.

#### RESERVOIR PAINT-BRUSH.

AN English firm has invented a painting-brush, the advantages of which, in comparison with the usual kind, is that it is made of first class bristles selected for the purpose; its shape is nearly flat, and set in thin copper binding, and firmly cemented. The most remarkable claim for the invention is, that the center of the brush forms a small chamber for the paint, which is worked up to the flag or top of the brush by the arrangement of the bristles, which are so placed to effect this purpose, that, while the brush is in use, it is working the color to the surface and never becoming clogged.

#### ORNAMENTED GERMAN TEXT.

*Illustrated on Plate XLIII.*

THE custom to use an ornamental letter for the panels of buggies, &c., has become so general, that we think we can do our subscribers no better service than to devote a plate to showing specimens. We believe it will be found useful in the paint-shop.

### Trimming Room.

#### CARRIAGE LACES.

THREE articles are used in the manufacture of carriage laces: wool spun into yarn; linen thread, finely dyed of different colors, and silk of two kinds; the weft, technically called "tram," and the warp, much coarser and stronger, called "organzine;" the entire work, as it is, never being bound by another weft, simultaneously.

The best silk laces now used in trimming carriages is made from the finest worsted, dyed with the fastest and best dyes; the ground-work being of the best linen-thread; the warp that binds the silk ground of very fine twisted or organzine silk, and the weft of fine wove silk, of a sufficient number of ends to thoroughly cover the warp, and to produce a rich appearance where the silk shows. The cotton weft should consist of two threads of fine even cotton, so that it will allow the figure of the lace to be struck up about twenty-two wires to the inch. The edges should be of solid silk twist, and the whole of the warp passed through a reed, or slay, with nineteen openings to the inch across the lace.

For the inferior lace, that usually used in second-

class work, the commonest worsted and dyes, liable to fade very soon, are employed. For the ground-work, cotton is used in the place of linen. The warp is also cotton, with a *temporary* gloss to imitate silk. This very soon wears off and leaves a number of faded stripes along the lace, to the great disfigurement of the trimming. The weft is of course and uneven silk, known as floss, which soon tarnishes, giving the lace a rough, woolly appearance. The second weft consists of about five ends of coarse, uneven cotton, which prevents the figure of the lace being what is termed, "struck up" more than sixteen or seventeen wires to the inch; thus materially diminishing the time and labor consumed in the manufacture. Instead of being made of silk twist, the edges are made of cotton, slightly covered with silk, while the reed, through which the warp is passed, has two or three wires less to the inch than for first-class work. This is the reason why the second weft must, in the case of inferior lace, consist of so many threads of cotton; there are so many wires less to the inch the way of the figure, and so many threads less across the lace; it must, therefore, be filled out, and so a temporary substance is given by means of an additional quantity of cotton. Some of the above remarks apply to seaming and pasting laces as well.

In making one yard of the best lace, it is estimated that the shuttle passes through the warp 3,168 times, and the wires used in weaving, drawn out and put in 1,584 times, and the action of the feet on the treadles is about 3,960 movements, while the lace pattern is put back by the hand the same number of times, the total number of movements being 12,572, which is 2,940 more than required to produce an inferior quality of lace.

Our civil war has very seriously affected the costs of carriage laces. A year ago, the best silk lace sold for 55 and 65 cents, now they are worth 85 and 90 cents. Luckily, laces are not as much used now as formerly; were it otherwise, we have very little doubt that they would at this time command, at least, \$1 per yard.

MIXTURE FOR REVIVING THE LEATHER OF CARRIAGE-TOPS.—Take of ivory black, one pound; lamp-black, one pound; levigated indigo, one ounce; gum-arabic, four ounces; brown sugar, six ounces; half an ounce of glue dissolved in two pints of hot water; mix the whole well, and then it is ready for use. If required to thin it, add half an ounce of spirit of wine.

### Editor's Work-bench.

#### LEAKAGE SOMEWHERE.

Success in any business is wholly dependent upon the care and attention we bestow upon it. Never was a truer maxim promulgated, than that in Poor Richard's Almanac:

"He who by the plough would thrive,  
Himself must either hold or drive."

In the strongest sense is the sentiment applicable to carriage-making. It being a complicated kind of business, demands of those who engage therein, the closest attention, in all its details, to guard against leakages, particu-

larly in times like the present, when stock and labor are so enormously high. Inattention to that careless apprentice, or that wasteful journeyman, has been the serious loss to the manufacturer of hundreds of dollars in the course of a year. No wonder that so many fail in the business; they are too negligent of the little matters—the serious leakages—going on in the manufactory. Those who wish to employ their money to the best advantage, must with it use attentive oversight, an outlay of mental stock, a capital of capacity, in order to reach a desirable end—certain success.

As we have often before inculcated, arithmetic is a very useful thing in a carriage shop. Deficiency therein has been the ruin of many would-be business men. We very much doubt if one-half the carriage-builders in the land know how much it costs them to build a carriage. They generally find out in some way at what price a neighbor sells his work, and having learned thus much—often taking the unsupported word of an interested customer—they conclude that they can sell a little less, and so secure custom, without going to the trouble of a little figuring, so as to post themselves and find out for certain where they stand.

We remember a conversation we held with a certain carriage-maker, who always had a "run of work," plenty to do. He declared it to be his policy to always work cheaper than his neighbors, so as never to stand in need of custom *any way*. What was the consequence? That man did have plenty of work as long as he paid the dealer's bills, but the leakages from working on *the cheap plan* soon broke up his business, and he had to wind up with paying 15 per cent. on the dollar. To-day he is working at the bench as a journeyman in the same shop where he once flourished as the boss thereof. A humiliating position, truly. It was the practice of a distinguished mechanic of this city, to send all who came to him for cheap-work to a neighbor who was famed for doing such. He said it was the readiest and best mode of getting rid of such competitors. In our experience, we have found such to be the case. All the cheap-work mechanics—without a remembered exception—have "played out." It will not pay to work for cost, *not even where a large business is done!*

The lack of attention to those who are allowed to cut up plank, leather, and other stock, is also a serious kind of *leakage* to the manufacturer. A large proportion of the men engaged as workmen in our manufactories, seem to have no manner of care in this respect, more than to hack and cut, regardless of consequences; and follow them to their homes, the same want of judgment is seen in their domestic affairs. Economy finds no place in their habits. It would seem to be a constitutional weakness, which a timely and proper education might, to a great extent, have overcome; but which has now become

chronic. For such we entertain no hope. *Leakage* of the most ruinous kind, as far as they are concerned, must sooner or later blight all their business prospects. Reader, how many of this character can you enumerate among your acquaintances? How many have failed in business because of a leak somewhere?

#### A CLEAN SHOP AND THINGS IN PLACE.

If there is anything that gives us more satisfaction than another, next to that of seeing a neat and perfectly-finished carriage, it is to find the workshop and its appendages regularly and cleanly swept, and everything about it in place—in its own place—so that the hand could be laid upon it, even in the dark, should a thing be needed. Deficiency or neglect in this respect is the prolific source of trouble and perplexity on many occasions. A customer may be waiting at the door for some trifling repair to his carriage, which may be attended to in ten minutes if things are in place; different from this, half an hour may be wasted in searching out the most trivial instrument wherewith to do a job, to the great trial of his patience. There is no more effectual charm for securing custom, than punctuality; but how can punctuality be shown where time is squandered in getting ready?

We once heard of a pupil who was taking lessons in boxing, but whose dilatory movements allowed his teacher to knock him off the log on which both were seated. As the pupil fell, the master cried out: "The first lesson for inculcation, is, 'to be ready in time.'" Although we cannot endorse such a *mode* of instruction, still the lesson taught has a moral—to always be ready to despatch business, when such offers.

Need we say here that a clean carriage, in a clean wareroom, will sell for a higher price than when found in a different condition. The fact is apparent to every observer, and a judge of human nature has only to cast his eyes around, and at once decide the mechanical *status* of the presiding genius—or it may be lack of genius. There can be no better evidence of the laziness of an individual, than to find him habitually engaged in attempting to work in filth and dirt. A clean shop and a good mechanic are synonymous terms.

#### REVIEW OF TRADE.

ALTHOUGH a terrible civil war is raging over some portions of this country, still there seems to be plenty of work in this locality, and as was stated in our last, in other parts of the Northern States. A different state of things exists on the other side of the Atlantic, as we learn from an English correspondent. He writes: "Business in London is rather slow just now. The war in Denmark has broken out so suddenly as to surprise people and make them cautious in ordering and paying, especially for carriages and harness."



On reading the passage, our curiosity was awakened to learn how a war in Denmark could affect the carriage trade so seriously in England. A little reflection solved the question. Our readers will bear in mind, that the present King of Denmark is father to the Princess of Wales, while the King of Prussia is father-in-law to the eldest daughter of Queen Victoria; and besides, the half-sister of England's Queen is the wife of the Duke of Augustenburg, who is the next male heir of the late king. These facts, undoubtedly, have had a serious effect upon the minds of the British aristocracy, and for the moment, a deleterious effect on all business, especially upon the sale of carriages.

The past month is characterized as one of strikes in almost every department of labor, especially those mechanical. The painters tell the public that "the class that coach-makers deal with is able and willing to pay any reasonable demand;" and acting, as though such was the truth, demanded from 25 to 50 cents more per day, and are now generally receiving it. The premium on gold has advanced the prices of most of the necessities of life, and doubtless, labor should receive a higher reward, but we find a great many customers refuse to pay an advance on the prices of either purchases or of repairs, and consequently, we fear that the coachmaker's harvest, this year, will be of short duration. No one will be more pleased than we are, if such be not the case. In our last, the printer made us say that the price of a top-buggy in New York was \$265, whereas it should have been \$365. From present observation, we judge that the market is not likely to become over-stocked with made-up carriages this season. Very few manufacturers will risk their capital in such wares as carriages, while it costs so large an outlay to produce them, except where they are ordered beforehand.

#### FAMILY CARRIAGE WANTED.

WE find in the *American Agriculturist* the following article from a correspondent, for the invention of which the Editor makes reference to us:—

"I keep 'one family horse,' a strong one, yet I often desire to go to church (two miles) and elsewhere, with wife and four children, requiring three double seats, or two wide ones. In stormy weather we need curtains down, and a glass door or look-out at the sides. The common rockaway, or carry-all, answers, but it is too high to get into by small children, and especially by a feeble woman, while the box prevents the fore-wheels turning short. A desirable vehicle would be one at a moderate, or not large price, built after the hack style, with *low middle*, the fore-wheels turning under, and the door opening down to the step; the *sides high enough, clear to the dash board*, to keep mud from flying in, and a small child on the front seat from falling out; the two back seats to be far enough apart to allow ladies to sit facing each other, *with room enough for their crinoline*; a moveable hood in

front, and a rain-cloth rolled upon the dash-board. I fear the difficulty will be to get in all these requisites without making the carriage so long as to appear too large and clumsy for one horse, even if it be light enough to be drawn by one. I have not seen a family carriage of the kind. Can one be built?"

Our friend, the Editor, says he has looked in vain through the principal establishments of this city, for a carriage as described in the foregoing extract; but thinks, perhaps, some one of the craft (among which we are included) may be able to help in the matter. The craft can speak for themselves through our columns—if they choose to do so.

For ourself, we fear that all parties will be doomed to disappointment if they rely upon us to perform that which we deem to be an impossibility. The gentleman may just as well purchase a coach; for the carriage he wants could neither be made cheaper, nor drawn easily by a single horse, even was the building of it practicable. The coach would very likely look symmetrical and tasteful; the new carriage would have neither of these qualifications. This is our judgment—what say our readers?

#### EDITORIAL CHIPS AND SHAVINGS.

TO OUR EXCHANGES.—Some of our exchanges are in the habit of addressing their publications to E. M. Stratton, 82 East 14th Street, which subjects us to expense of postages; whereas, the direction should be "Coach-maker's Magazine, N. Y.;" then they reach our exchange-box, and cost us nothing. Will our Editorial friends take notice and correct accordingly.

SUDDEN DEATH OF AN OLD CARRIAGE-MAKER.—Died very suddenly, February 26th, 1864, of an apoplectic stroke, Mr. Lawrence Brower, in the 66th year of his age. Mr. B. had for a number of years enjoyed an enviable reputation for building good work, and was extensively known throughout the country. We shall miss him from our midst.

PERSONAL.—Our friend, Mr. Danl. Dusenbury, has removed from his old stand at 102 Laurens Street, into a better and more substantial building, a few doors below. We understand that on the first of May, Messrs. Stivers & Smith will dissolve partnership; Mr. Smith retiring and Mr. Stivers removing to larger premises in 31st Street, near Lexington Avenue. Also that Mr. Stevens retires from the firm of Miner, Stevens & Co. this spring. There are other changes which may be noticed hereafter.

A MILITARY OFFICER'S TRAVELING OFFICE.—A traveling office wagon has recently been constructed in the Government shops at Washington, for the Adjutant-General's Department of the Cumberland. It is altogether a novelty, so constructed as to be taken apart and put together in five minutes; is drawn by four horses, and will accommodate seven clerks and a driver. A similar one will shortly be completed for Gen. Pleasanton, Army of the Potomac.

NOISE FROM CARRIAGES ON PAVED ROADS.—A writer in the *London Builder* suggests, that in order to mitigate the noise from carriages on paved roads, that venders of

any kind of wood be placed between each course of carriage-way stones. Another writer in the same journal recommends paving the sets about one inch apart, and filling up the joints with small hard clean stone chippings;  $1\frac{1}{2}$  inches deep all over the pavement, except the channels; then pour out just sufficient asphalt to bind the whole together in one solid mass.

"SECESH" HISTORICAL PAINTING, IN WHICH A COACH FIGURES.—The Rebels are trying to be merry, while starving. Hear what the *Richmond Whig* says in relation to a subject for a Confederate historical painting: *Enquirer* man—not the editor—he is "nameless here for evermore"—tearing up the Confederate Constitution for waste paper. Mr. Memminger picking up the pieces to print fifty cent Confederate notes on. Framers of the Confederate Constitution in the background, sitting on mourner's bench, wiping their weeping noses on illustrated cotton pocket handkerchiefs. Detailed editor of independent paper, dressed in uniform of artillery private of Confederate States, going out to be shot as a deserter for not spelling "liberty" Libbyty, preceded by a band playing "When this cruel war is over." "Unembarrassed Government," in the shape of a six-horse coach, with the drag-chain broke, being backed by a stubborn mule down a steep hill into the gulf of despotism. Mr. Benjamin looking out of the coach window, and singing "Peace by the next mail from Europe." To be painted in oils (made out of lard, at \$4 a pound,) and suspended in the commissary department.

#### LITERARY NOTICES.

THAT charming periodical, *The Atlantic Monthly* for February, is on our table. Its contents are varied and interesting. We have been especially gratified with: "Wet-weather Work," "On the Relation of Art to Nature," "House and Home Papers," "Our Soldiers," &c. In the language of another we would say: "No library is complete without this serial."

Our friend, the publisher of the *Historical Magazine*, has recently made additions to his pages, and now gives an occasional illustration. We esteem this one of the most useful periodicals ever issued from the American press. A volume began with January, presenting a good time for subscribing. Price, \$3 a year.

#### FOREIGN IMPROVEMENTS IN CARRIAGES.

AXLE BOXES.—Feb. 19, 1863, R. P. Roberts, Kensington Oval.—This invention consists in the method of securing the box in the hub or nave, which is accomplished by the use of a conical or wedge-shaped nut on the end of the box, which, when screwed up, operates both to wedge and clamp the box in the hub or nave. *Not proceeded with.*

BRAKES.—March 9th, 1863, J. Haworth, Manchester. This invention consists in applying a metal clip, lined with leather or other suitable material, for increasing the friction to the nave of one or more of the wheels of an omnibus or other carriage, and in connecting the two ends of the clip to a double lever, which is in communication with a treadle or handle. *Not proceeded with.*

CARRIAGES.—March 9, 1863, J. R. Gorst, Liverpool.—This invention has for its object the construction of carriages in such a manner as to facilitate their draft by the use of wheels of increased diameter, and to admit of the center

of gravity of the carriage being lower than usual. For this purpose the shank of the axle-tree is lengthened, as required, and is made to form (either with or without the aid of a pieced crank) a fixed vertical guide for a grooved slide, which carries a box in which the upper part of the said shank is inclosed, in such a manner as to give stability to said shank, and prevent the box and slide from moving thereon in any but a vertical direction, to an extent limited by the length of the slot in the box, and by fixed steps. The upper part of the shank of the axle-tree, where the axle is inserted, is strengthened by two side pieces, which fit the hollow space in the box, and are brought in contact with the said fixed steps as the box is pressed upwards to its extreme height by the spring, or downwards by the weight on the body of the carriage. At the lower end of the shank of the axle-tree there is a cross-piece or crutch, to which is or are fixed a spring or springs, and which extend to a corresponding cross-piece or crutch at the bottom of the shank on the opposite side of the carriage. This spring or springs is or are intended to take the smaller weight, that is to say, the weight of the unloaded carriage, and there are two side springs (one on each side of the carriage) fixed at their ends to the body of the carriage, and bolted in the middle to a cross-piece fixed on to the shank of the axle-tree, which springs are intended to take any greater weight put upon the carriage. Or there may be two springs on each side, fixed between the bottom plate of the said box and the said cross-piece for the same purpose.

ODOMETERS.—L. A. Benel, of Paris, April 22, 1863.—This invention consists, *First*, in a method of indicating whether the vehicle is disengaged or employed. *Secondly*, in showing the distance traveled over, and the time the vehicle has stopped, calculated or represented in distance. *Thirdly*, in a mode of marking, indicating and verifying or proving the work performed by the vehicle. A suitable external sign is placed on the front and top of the case of the mechanism, or on the driver's box, for indicating that the vehicle is disengaged, or not hired. But when a fare is taken, the driver turns a handle a quarter of a circle, causing thereby the external sign to be lowered and to disappear, and at the same time to actuate the gearing required for the motion of the apparatus three separate operations. The first shows that the vehicle is not hired; the second, or the first turn of a quarter of a circle, shows that the vehicle is hired by the mile, that is to say—the distance run over, to which may be added the time of the stoppages, represented by the proportional mean of the distance (calculated at about five miles per hour.) The third operation indicates the slow motion of the vehicle, that is to say—that independently of the velocity of the vehicle, the mile or distance index will constantly indicate a mean velocity of the vehicle when in motion, and its stoppages. By these means only one tariff per mile for all cases is required. When the fare leaves the vehicle, the hand is returned to its rest mark, the mileage index hand returns to O, and internal sign re-appears. All these operations shown to the fare, or traveller, are written or marked on an internal plate or dial; also the time of each of these operations.

#### AMERICAN PATENTED INVENTIONS.

DEC. 1. PRODUCING OIL AND SPIRITS OF TURPENTINE FROM PINE WOOD.—S. L. Cole, of Burlington, Vt.: I claim the dis-

covery or invention of producing oil or spirits of turpentine and other analogous oils directly from wood, using for that purpose the apparatus hereinbefore described, or any other substantially the same, and which will produce the intended effect.

CONSTRUCTING WAGONS, CARRIAGES, &c.—John Kirkman, of Peoria, Ill.: I claim in combination with a wagon constructed as described, the springs, *I J'*, rods, *II*, eccentrically pivoted arms or rods, *ff*, and rubbers, *gg*, all arranged and operating substantially as set forth.

OPERATING WAGON BRAKES.—James H. Lee, of Leavenworth, Kansas: I claim, *First*, The combination with the brake lever, *B*, of a spring, *G*, to throw the said lever into the rack, *F*, automatically when drawn forward. *Second*, The combination of the lever, *I*, spring, *D*, and lever, *K*, or cam, *I'*, operating to release the brake lever, *B*, and retract the brake, substantially in the manner described.

CARRIAGE SPRING.—Gallus Woeber, of Davenport, Iowa: I claim the lugs, *h*, projecting from the edges of the leaf, *d*, of a spring, *A*, and operating in combination with the pins, *g*, and leaves, *c b*, in the manner and for the purpose substantially as specified.

Dec. 8. CONSTRUCTION OF BUGGIES.—Jonathan H. Bye, of Sterling, Ill.: I claim, *First*, The combination of the thills, *aa*, with the springs, *bb*, and *cc*, for the purpose and in the manner herein described. *Second*, The combination of the coupling, *mm*, with the rear springs, *ss*, and *rr*, the curved continuation, *nop*, of the coupling, *mm*, the beam, *j*, with its guides formed by *l*, and *ii*, and the flexible bar, *h*, substantially as set forth.

Dec. 22. MACHINE FOR MAKING CARRIAGE WHEELS.—G. W. Hatch, of Parkman, O.: I claim, *First*, The frame, *A*, bed, *B*, rod, *C*, swivel, *E*, and attachments, *G* and *H*, arranged as and for the purpose specified. *Second*, I claim the arms, *J*, and crosshead, *K*, for receiving and operating the head blocks as set forth. *Third*, I claim the graduated scale, *L*, in combination with head blocks, Nos. 12 and 3, and cross head, *K*, constructed and operated substantially as and for the purpose specified. *Fourth*, I claim the table figure, 3, when constructed substantially as described, and for the purpose of holding the felloe while being bored, as set forth.

Jan. 12, 1864. DEVICE FOR SHRINKING TIES.—Joseph Olmstead (assignor to T. P. Dinsmore), of Chicago, Ill.: I claim the arrangements of the brackets, *ec*, projecting from the ends of the eccentric, *D*, in combination with the wrist-pin, *d*, pitmans, *EE'*, and hand lever, *F*, constructed and operating as and for the purpose shown and described.

TIRE UPSETTING MACHINE.—L. A. Dole (assignor to himself, and A. B. Silver), of Salem, O.: I claim, *First*, Making the wrought metal key retainers of the tire upsetting machine, with a contracted slotted portion, *a*, terminating in an enlarged eye, *b*, for the purposes described. *Second*, The use of transverse wedge keys with *V* edges, in combination with the wrought metal loops, *A*, applied to the anvil, *B*, substantially as described.

BLACKSMITH'S TUYRERE.—William Sharp, Millport, N. Y.: I claim the combination and arrangement of the partially rotating disc, *D*, and stationary bed plate, *C*, provided with the unvarying opening, *e*, and variable openings, *gf*, for their equivalents, with the blast pipe, *A*, and blast chamber, *B*, substantially in the manner and for the purposes shown and described.

19. METALLIC PONTOON WAGON BOAT.—Joseph Francis, of New York City: I claim combining and arranging pontoons formed of two parts, substantially as described, with the staples and bars, *S*, and windlass apparatus or its equivalent, for holding the balks, by which the pontoons are united and formed into a bridge, by which combination I form a light and portable pontoon bridge, easily laid down and taken up with a small body of men and which can be transported with safety and rapidity as herein fully made known.

WAGON BRAKE.—S. H. Miller and Edmund Grubb, of Liberty, Ill.: We claim the combination of the equalizer, *d'*, and guide-bar, *C*, with the rear end of the sliding tongue, *D*, and with the break beams, *F*, and adjusting fulcrum bars, *H*, as and for the purpose herein shown and described.

WHIFFLE-TREE ATTACHMENT.—Ephraim Soper, of New York City: I claim as an improved article of manufacture, a whiffle-tree attachment, composed of plates, *C C'*, hook, *F*, extension edge, *d*, and tube, *a*, made and applied as herein shown and described.

TRACE FASTENER.—F. M. Weller, of Evanston, Ill.: I claim the hook, *A*, provided with the stationary anterior and posterior projections, *a a'*, constructed and arranged substantially as described.

26. LATHES FOR TURNING SPOKES.—Theophilus Derrington, Du Quoin, Ill.: I claim, *First*, Controlling the lateral motion of the cutters, and at the same time feeding them up to the work of making spokes by means of a single pattern, constructed and operating substantially as described. *Second*, A spoke pattern, constructed with a spiral screw thread on its surface, substantially as and for the purposes described. *Third*, The oscillating traveling carriage, *H, J*, in combination with the traveling weight, *I*, tooth, *n*, and a spoke pattern, operating substantially as described.

SPOKE-SOCKET AND FELLY CLAMP.—L. D. Flanders, Cleveland, O.: I claim the plate, *C*, socket, *A*, lugs, *BB*, and lips, *aa*, all cast in one piece and secured to the felloe by means of the screw, *bb*, substantially as and for the purpose specified.

SPRING FOR VEHICLES.—John E. Tabor, Fall River, Mass.: I claim the springs, *E*, fitted on the rods, *D*, and connected thereto, and the frame, *B*, in connection with the tubes, *G, H*, collars, *F, I*, all arranged substantially as and for the purpose herein set forth. I further claim, the connecting of the spring *E*, to the frame, *B*, by means of the bars, *J*, collars, *I*, and joints, *e d*, when used for the purpose herein specified.

Feb. 9. WHEEL VEHICLE.—Lorenzo D. Brown, Lafayette, Ind.: I claim, *First*, The stirrups, *D*, hinged to the bolster, *E*, in combination with the axles, *C'*, of the front wheels, *B'*, and with the draught-pole, *F*, all constructed and operating in the manner and for the purpose substantially as shown and described. *Second*, The spliced bolster, *K*, to operate in combination with the axles, *C*, and with the reach, *G*, substantially in the manner and for the purpose set forth.

WAGON SPRING.—Charles S. Martin, Mackford, Wis.: I claim, *First*, The combination of the spring, *A*, bolts, *BB*, clasp or hanger, *C*, cup, *D*, and washer, *E*, in the manner and for the purpose herein described. *Second*, In combination with the foregoing, I claim the coupling, *H* and *G*, in the manner and for the purpose herein described.

THILL FASTENING.—Samuel S. Melley, Lebanon, Pa.: I claim, *First*, The application of a looped fastening, *D*, to the removable coupling bolt, *C*, substantially as described. *Second*, A pivoted spring looped fastening, *D*, constructed with a forked end, in combination with a bolt, *C*, constructed with an enlarged shoulder on one end, adapted to enter eye, *a*, and a tenon, *d*, on the opposite end adapted to receive and to form a lateral support for the free end of the loop, substantially as described. *Third*, The combination of clip eyes, *aa'*, bolt *C*, thill eye, *b*, and loop fastening, *D*, constructed and operating substantially as described.

SHAFT COUPLING FOR CARRIAGES.—Francis B. Morse, New Haven, Conn.: I claim a coupling for carriage shafts, in which the movable part of the joint has the eyes forged thereon, and a cavity in its rear end to receive an elastic presser, to prevent rattling as herein described. *Second*, I claim the combination of the head, or movable part of the joint, as described, with the stationary jack and elastic presser, substantially as herein described.

16. WAGON BRAKE.—Erasmus Bennett, Clarksville, N. Y.: I claim the sliding-hounds and pole, when used in connection with the arms, *M, N*, and rods, *Q, R*, connected with the rubbers, *T, U*, and eye, bolt, or pin, *Z*, all arranged and combined as set forth and for the purpose specified.

DUMPING CART, OR WAGON.—Isaiah B. Conklin, Pemberton, N. J.: I claim the bar, *F*, pivoted to the shafts, *C*, and controlled by springs, *f*, and staples, *G*, when used in combination with the hooks, *HH*, rightly attached to the cart body, *A*, all as herein shown and described and for the purpose specified.

## CURRENT PRICES FOR CARRIAGE MATERIALS.

NEW YORK, March 18th, 1864.

Apron hooks and rings, per gross, \$1.25.  
 Axle-clips, according to length, per dozen, 75c. a \$1.25  
 Axles, common (long stock), per lb, 10½c.  
 Axles, plain taper, from ¾ to 1 in., \$6; 1½ in., \$6.50; 1¾ in., \$7.  
 Do. Swelled taper, 1 in. and under, \$6; 1½ in., \$7; 1¾ in., \$8.50; 1¾ in., \$10; 1½ in., \$12.  
 These are a superior axle, and more frequently called for than any others.  
 Do. case-hardened, half-patent, 1½ in., \$7; ¾ in., \$7.50; 1¾ in., \$8.50; 1¾ in., \$9.  
 These are prices for first-class axles. Makers of less repute, cheaper.  
 Bands, plated rim, under 3 in., \$2; over 3 in., \$2.50.  
 Do. Mail patent, \$2.50 a \$3.75.  
 Do. galvanized, 3½ in. and under, \$1; larger, \$1 a \$2.  
 Basket wood imitations, per foot, \$1.  
 When sent by express, \$2 for a lining board to a panel of 12 ft.  
 Bent poles, each \$1.25.  
 Do. rims, under 1½ in., \$2.25 per set; extra hickory, \$2.50 a 3.50.  
 Do. seat rails, 44c. each, or \$4.50 per doz.  
 Do. shafts, \$6. a \$7.  
 Bows, per set, light, 85c.; heavy, \$1.12.  
 Bolts, Philadelphia, at new list.  
 Do. T, per 100, \$3 a \$3.50.  
 Do. tire, \$1.25 a \$1.80 a \$2.40, according to size.  
 Buckram, per yard, 30c. to 35c.  
 Buckles, per gross, 88c. a \$1.25.  
 Burlap, per yard, 25c.  
 Buttons, japanned, per paper, 20c.; per large gross, \$2.25.  
 Carriage-parts, buggy, carved, \$4 a \$5.  
 Carpets, Brussels, per yard, \$2; velvet, \$2.75 a \$3.75; oil-cloth, 60c. a 80c.  
 Castings, malleable iron, per lb, 15c.  
 Clip-kingbolts, each, 35c.  
 Cloths, body, \$3.75 a \$5.50; lining, \$2.25 a \$3.25. (See *Enamelled*.)  
 A Union cloth, made expressly for carriages, and warranted not to fade, can be furnished for \$2.25 a \$2.50 per yard.  
 Cord, seaming, per lb, 25c.; netting, per yard, 5c.  
 Cotelines, per yard, \$6 a \$8.  
 Curtain frames, per dozen, \$1 a \$1.50.  
 Do. rollers, each, \$1 a \$1.25.  
 Dashes, buggy, \$1.75.  
 Door-handles, stiff, 50c. a 63c.; coach drop, per pair, \$2 a \$3.50.  
 Drugget, felt, \$1.62.  
 Enamelled cloth, 5 qrs., 75c.; 50 in., \$1.55.  
 Enamelled cloth ranges from 80c. to \$1.55, according to width and quality.  
 Enamelled linen duck, 4 qrs., 55c.; 5 qrs., 75c.; 52 in., 90c. Colored, 15c. higher per yard.  
 Felloe plates, wrought, per lb, all sizes, 20c.  
 Fifth-wheels wrought, \$1.38 a \$2.  
 Fringes, festoon, per piece, \$2; narrow, per yard, 18c.  
 For a buggy top two pieces are required, and sometimes three.  
 Do. silk bullion, per yard, 35c. a 75c.  
 Do. worsted bullion, 4 in. deep, 35c.  
 Do. worsted carpet, per yard, 6c. a 10c.  
 Frogs, 50c. per pair, or \$1.63 per dozen.  
 Glue, per lb, 25c.  
 Hair, picked, per lb, 30c. a 60c.  
 Hub-borers (Dole's) for light work, \$15; heavy, \$18 a \$20.  
 Hubs, light, morticed, \$1; unmorticed, 75c.—coach, morticed, \$1.50  
 Japan, per gallon, \$4.75.  
 Knobs, English, \$1.75 a \$2.  
 Laces, broad, silk, per yard, 85c.; narrow, 12c. to 15c.  
 Do. broad, worsted, per yard, 37½c.  
 Lamps, coach, \$14 a 18.  
 Lazy-backs, \$9 per doz.  
 Leather, collar, dash, 31c.; split do., 18c. a 31c.; enamelled top, 31c.; harness, per lb, 55c.; flap, per foot, 25c. a 30c.  
 Linen, heavy, a new article for roofs of coaches, 60c. a 90c. per yard.  
 Moquet, 1½ yards wide, per yard, \$7.  
 Moss, per bale, 10c.  
 Mouldings, plated, per foot, 12c. a 15c.; lead, door, per piece, 30c.  
 Nails, lining, silver, per paper, 8c.; ivory, per gross, 31c.  
 Name-plates.  
 See advertisement under this head on 3d page of cover.  
 Oils, boiled, per gallon, \$1.50.  
 Paints. White lead, extra, per 25 lb \$3; Eng. pat. black, 31c.  
 Pekin cloth, per yard, \$4.50.  
 A very good article for inside coach linings.

Plushes, per yard, \$2 a \$3.  
 Pole-crabs, silver, \$5 a \$6; tips, \$1.25.  
 Rubbing stone, per lb, 12c.  
 Sand paper, per ream, \$4.50.  
 Screws, gimlet.  
 Add to manufacturer's printed lists 20 per ct.  
 Do. ivory beaded, per dozen, 38c. per gross, \$4.  
 Scrims (for canvassing), 20c. a 25c.  
 Seats, buggy, pieced rails, \$1.75; solid rails, \$2.50.  
 Shaft-jacks (M. S. & S.'s), light, \$2.80; heavy, \$3.25. a \$3.50.  
 Shaft jacks, common, \$1.12½ per pair.  
 Do. tips, extra plated, per pair, 35c.  
 Silk, curtain, per yard, \$1 a \$2.50.  
 Slat-irons, wrought, per pair, 75c.  
 Slides, ivory, white and black, per doz., \$12; bone, per doz., \$1.50; No. 18, \$1.75 per doz.  
 Speaking tubes, each, \$6.50.  
 Spindles, seat, per 100, \$1 a \$1.25.  
 Spring-bars, carved, per pair, \$1.25.  
 Springs, best temp. Swedes, per lb, 29c. a 30c.; black, 22c.; bright, 23c.; best tempered, 25c.  
 Two springs for a buggy weigh about 28 lbs. If both 4 plate, 34 to 40 lbs.  
 Spokes, buggy, per set, \$3.60, or about 6c. each for all under 1½ in.  
 For extra hickory the charges are 8c. each.  
 Steel, Farist & Co.'s Homogeneous American, per lb, 18c.  
 Do. English Homogeneous, do. 22c.  
 Do. Compound tire, from \$8.50 to \$9, according to thickness.  
 Stump-joints, per dozen, \$1.25 a \$1.75.  
 Tacks, 6c. and upwards per paper.  
 Tassels, holder, per pair, 63c. a \$1; inside, per dozen, \$3; acorn trigger, per dozen, \$1.25 a \$1.50.  
 Terry, per yard, \$7.  
 Top-props, Thos. pat., per set, 40c.; plain, com., 35c.  
 The patent props, with silver-plated nuts, per set, \$1.  
 Tufts, ball, per gross, 80c.; common worsted, 12c. a 25c.  
 Thread, Marshall & Co.'s Machine, No. 432, \$2.40 per half lb; No. 532, \$2.75 do.; No. 632, \$3.50 do.  
 Turpentine, per gallon, \$3.75.  
 Twine, tufting, per ball, 45c.  
 Varnishes (Amer.), crown coach-body, \$5 a \$5.50; hard drying, \$6; nonpareil, \$6.50.  
 Do. English, \$6.25 in gold, or equivalent in currency on the day of purchase.  
 Do. American imitation of English, \$7.  
 Webbing, per piece, 44c.  
 Whiffle-trees, coach, turned, each, 25c.; per dozen, \$2.50.  
 Whiffle-tree spring books, \$3 per doz.  
 Whip-sockets, rubber, per dozen, \$7 a \$9; pat. leather, stitched, \$3.  
 Window lifter plates, per dozen, \$1.50.  
 Yokes, pole, each, 75c. to \$1.25.  
 Yoke-tips, 50c. a 75c.

Our Prices Current this month show another rise in many of the leading articles. Springs have also advanced 3 cents per pound. We would remark that when our friends send us orders we can only be governed by the ruling prices for that day, and that there is no certainty that prices may not rise the next day after our report, so changeable is the market. Cash orders preferred.

**Special Notice.**—We are sorry to say to our friends that we have barely received back, in sales, the money we have expended in publishing our last two volumes, and that the costs of production are now doubled. Under these circumstances, we must either receive a larger subscription list, increase the price to \$5, or suspend publication until better times come round. To either charge \$5, or stop, will be painful to us. We therefore propose that, within the next thirty days, our subscribers and friends see how many of their men and neighbors will take the VIth Volume, at the prices named on the first page of the cover, and let us know the result. Money need not be sent until the June No. is received. Your efforts and success will determine our future action. We hope to have a favorable response to announce in the next and closing number of this volume, from all who wish the work continued.



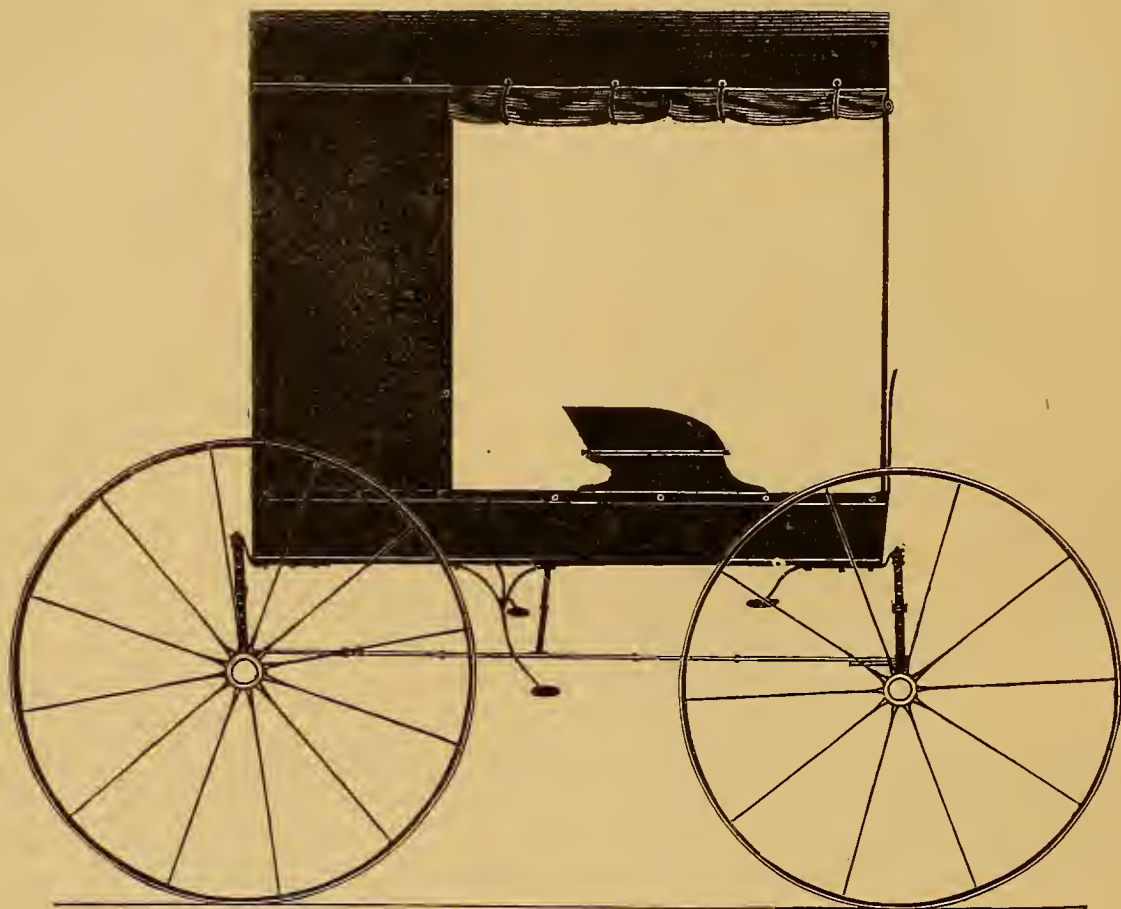

DEPÔT WAGON.— $\frac{1}{2}$  IN. SCALE.

*Designed expressly for the New York Coach-maker's Magazine.*

*Explained on page 184.*

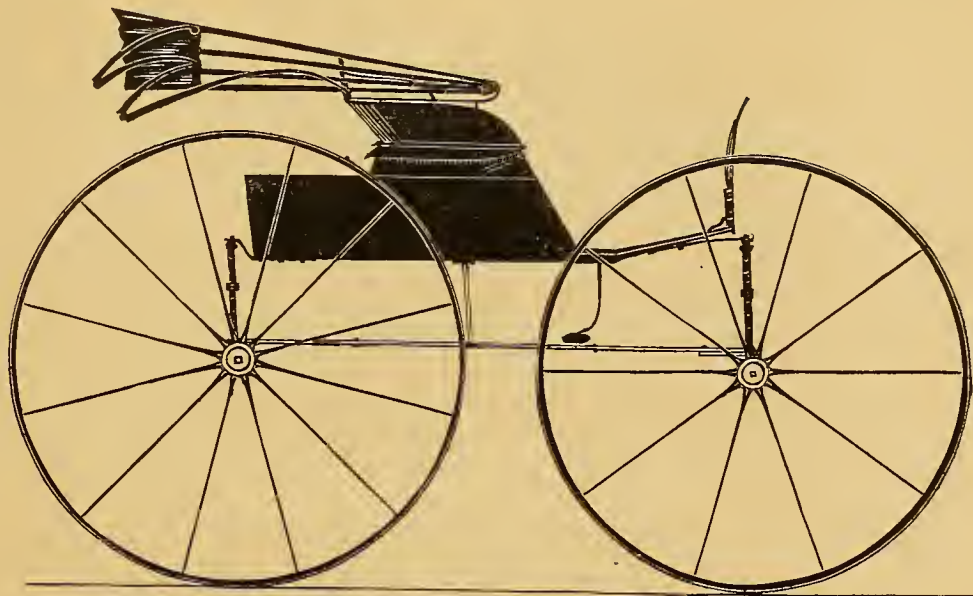

BRACKETED COAL-BOX.— $\frac{1}{2}$  IN. SCALE.

*Designed expressly for the New York Coach-maker's Magazine.*

*Explained on page 184.*







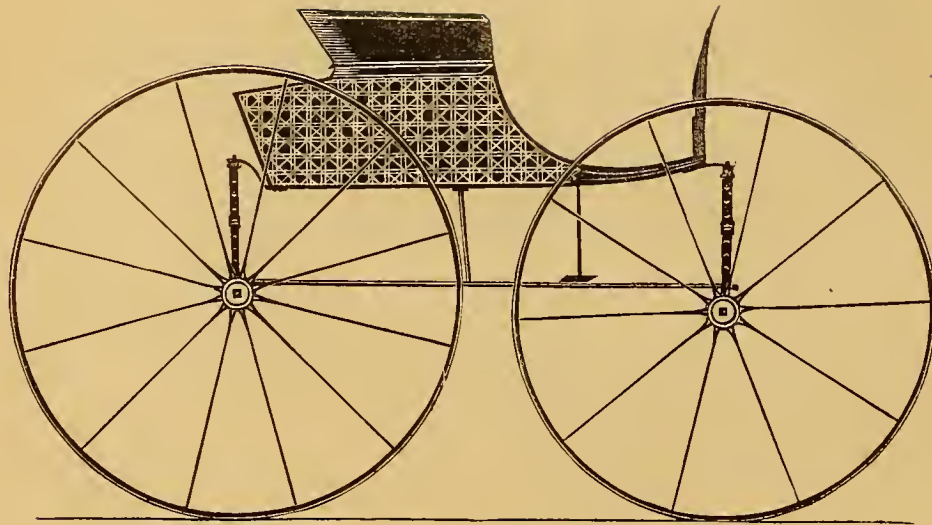

CANED BUGGY.— $\frac{1}{2}$  IN. SCALE.

*Designed expressly for the New York Coach-maker's Magazine.*

*Explained on page 184.*



DEVOTED TO THE LITERARY, SOCIAL, AND MECHANICAL INTERESTS OF THE CRAFT.

Vol. V.

NEW YORK, MAY, 1864.

No. 12.

## Mechanical Literature.

### WHY WHEELS ARE DISHED.

BY HENRY HARPER.

THE question of the comparative strength between dished and straight wheels has literally been a jug-handle question—theory on one side, and practice on the other; therefore, it is with great pleasure that I notice my friend, Mr. O. E. Miles, has stepped forward with his reasons for a practice that I have always deemed so absurd.

Mr. Miles says I have misstated the case in saying the strain comes on the bottom of the wheel, always crowding inwards. He says, "the crowding is done by the axle against the hub of the wheel, forcing it outwards." His statement of the case, he thinks, would have led me to more correct conclusions. I am free to admit that his statement about the axles crowding the hubs outwards is correct. If it were not so, my statement about the ground crowding the rim of the wheel inwards certainly could not be correct. Let Mr. Miles reflect a moment, and see if anything can be forced one way, and that force be resisted, without having the resistance act in an opposite way. All the difference is, that I have called resistance force, and he has called force resistance, when both terms express the same idea.

He says: "The resistance of the ground against the lower edge of the wheel causes the axle to act as a lever upon the hub of the wheel—the ground acting as a fulcrum," &c. I admit the first part of this statement, but deny that the ground acts as a fulcrum to the lever of the axle. The fulcrum to the axle would be either the large or small end of the axle-arm, when the axle operated as a pry within the axle-box. When this is the case, the wheel would act as a separate and distinct lever, in an opposite way to the axle. The fulcrum of the wheel would be either the large or small end of the axle-box. Let us examine Mr. M.'s representation of a broken-down wheel (see Fig. 1, page 162), and see if that does not prove the assertion that I have made. First, I will premise that the fulcrum is the part of the lever that receives the strain put on the arm of the lever to lift the weight, and the strain of lifting the weight concentrating twice the amount of the power at the fulcrum of the weight lifted.

Therefore, it requires the greatest amount of strength in machinery to be at and near the fulcrum, or it will break down, as Mr. M. presents in his figure. The honorable (we use the term to distinguish it from political) log-roller understands the principle in making his hankspike—he makes it the heaviest about where the fulcrum comes. The wheel-maker provides for it by making the spokes of the wheel the heaviest near where the fulcrum comes. Necessarily there must be a joint between the spoke and the hub, which leaves a weak point at the tenon; but this is easily provided for by making a dish to the wheel, throwing the strain endwise on the spokes, and finally transmitting it to the tire. Fig. 1, page 162, represents a wheel broken down at a place where the spokes are the largest, and where, according to Mr. Miles' theory, the strain is the least, because it is not at the fulcrum. He asks, "has the dish of the wheel protected it in the least against this disaster?" And says, if it has, "he don't see it." Does he see any reason for a wheel's breaking down where it is made the stoutest, and where the least strain comes? The strain that the axle makes on the wheel is lateral, as Mr. M. represents in Fig. 2, from *a* to *b*. He says that *c* is the fulcrum; and we must infer, from an undeniable law of mechanism, that there is twice as much strain at the fulcrum as on any other part of the wheel. Now, would it not be natural that the tenons of the spoke would break where they went in, at the rim, which is the weakest part of the wheel?

Mr. M. very naturally makes a mistake about the place of the fulcrum to the wheel, and it has led him to a wrong conclusion. His representation of a broken-down wheel is a very common one, but is far from being the only one. A wheel that breaks down in that way is extremely weak at the hub, so that the strength of rim has held the rim from bending out of position laterally; and the consequence has been that it could not be brought down to the ground without breaking the spokes on the upper side of the wheel. There is no other hard strain on the upper spokes of the wheel; and it must be remembered that this strain does not commence until the spokes on the lower side of the wheel have failed. Mr. M. says, "If the resistance to this forcing outward of the hub were offered to the whole rim simultaneously, instead, as it invariably is, to the lower edge only, it would have, as Mr. Harper says, only a tendency to stretch the tire, or force the spokes endwise into the hub. In fact, it would have

the same effect that pressure would upon any other arch ; but we have seen that the case is very different."

Friend Miles has certainly left out a paragraph which he meant to have inserted, for there is no other allusion to this *different case* in the article. I have said that forcing *any section* of the rim to the wheel inwards, toward the wagon, would enlarge the diameter of the dished, and diminish the diameter of the straight wheel. This is a "self-evident truth, not only too simple to require, but too simple to admit of demonstration"—a geometrical "axiom." Why friend Miles should deny it, I cannot comprehend. It is true that bending opposite sections of the wheel towards the wagon at the same time, would enlarge it twice as much. Mr. M. agrees with me that we can bend only the lower section at one time. Now, all that is wanting is to have dish enough in the wheel, so that we can bring the strain on the tire, by bending this lower section twice as much as would be required to strain the tire by bending the opposite parts of the wheel. For instance, if the wheel had one-fourth of an inch dish, and we should bend the lower section of the wheel in towards the wagon one-half an inch, then the wheel would be on a straight line to the opposite side, and the greatest diameter that could be made would be attained. If enough pressure is put on to bend the lower section of the wheel one inch in, the diameter is diminished also, and the strain on the tire, which strengthened the wheel until it reached the first half-inch, is lost. At first, bending the wheel in this way, more strain may be put on it without breaking it down, because an auxiliary help comes in by the way of the resistance of the tire and felloes to bending sideways ; also the resistance that the tenon of the spoke makes to being removed. But every time this strain comes on the wheel, this auxiliary help is weakened, and is generally shown by the "working" of the spokes in the hub. At this stage the tire has to be reset, and the dish increased, so as to strengthen the wheel. That time will come once in six months where too little dish is made, and not more than once in six years where enough dish is given. One half-inch is not enough unless we can afford to draw around with the wagon an unnecessary amount of weight to secure the required strength. A wheel with the least heft that can be required for the proper strength, will allow the spokes to crinkle sideways, until the rim of the wheel has been bent sideways enough to allow all the strain on the tire, and the ends of the spokes to be expended. There should not be less than one inch dish to a four-foot wheel.

Mr. M. thinks the dish is given to secure a certain amount of elasticity which they could not have if driven straight. Now, I do not know any necessity for an *elastic wheel* ; nor can I comprehend how it is secured by setting the tire on the wheel so that the spokes are curved forward, as they always are, by leaving the rim of the wheel open, and a corresponding draught of the tire to give the wheel a slight dish. Nothing can be more unsightly than this curve in the spokes for making the dish. But it is proved beyond a doubt, that strength is gained by the dish of the wheel. The spokes are all bent forward to make the dish, and the tire holds them from resuming their former straight position. Then so far as elasticity of the spokes is concerned, the wheel gets no support from going into the lateral movement which they are inclined to make. The strain on the tire is all the support the wheel has from bending inward, certainly, until

the spokes have become straight, yet the wheel is kept in this shape merely from the strain that is thrown on the tire and ends of the spoke, although there are heavy loads put upon it to crowd it in the direction that the elasticity of the spokes incline it.

I have no confidence in Mr. Miles' wheel made convex on both sides ; but that is a subject foreign to the one discussed, and to any practice that I have ever witnessed. I am thankful to friend Miles, for calling the attention of mechanics to a subject of so much importance, and I believe he will excuse me if I say that I think he had no other object in view but that very laudable one of leading men to *think* more than they are accustomed to on the subject.

### SETTING AXLE-BOXES.

BY O. E. MILES.

ALL who use wheel vehicles well know the great disadvantages resulting from want of trueness in the running of a carriage or wagon wheel. Let a wheel run so as to make a serpentine track, and the consequence is an immense increase of friction to be overcome by the team, as well as a corresponding increase of wear upon the axle and its box. Hence the importance of inserting the box at exact right angles with the rim of a wheel. It must then make a straight track, or follow easily and naturally the ruts made by other wheels.

There have many different ways come under my notice for determining the position of a box preparatory to boring the hub to receive it, and believing (as many conceited persons do) that my way is the best and most expeditious, I propose, with your permission, to give your readers a brief chapter of my experience, showing how I arrived at this important conclusion, and thereby, perhaps, teach some apprentice to avoid the rocks I split upon in this particular part of his journey.

I was taught, when first set to the duty of setting boxes, that I must put them as near the center of the hub at both ends as possible ; and, as far as my observation has served me, I believe nearly all apprentices are so taught ; I mean of that class who excavate their hubs by hand, as I have always done. I found, however, that when I tried my wheels on a mandrel or axle, that nearly every one run out of true, and then the position of one end of the box had to be altered by means of wedges. I have, "said I to myself," centered each end of every hub exactly, and planted the boxes accordingly, and had nearly all of them to alter, more or less, afterwards. Well, I plodded on in this way for months, sometimes having to wedge the box quite to one side of the hole I had made, not even dreaming of my right, under the Constitution, to examine into the propriety of doing as I had been taught by men of more experience than myself. The conclusion at last forced itself upon me, that it mattered not so much whether the box occupied the center of the hub at all, if, after putting it there, I am obliged to wedge it away from the center to make it stand perpendicular to the rim. Then why not consult the rim from the first, and make my calculations therefrom, regardless of the hub. I found, by actual experiment, that though the apparatus used by wheel-makers for fixing each spoke at the same angle with the axes of the hub, is constructed upon correct principles, yet, from various causes, exactness in

this particular is the exception. Experiment further proved, that a hub that does stand perpendicular to the rim when made, is liable to have this relation so changed by setting the tire, as to make the hub a very inaccurate guide by which to determine the position of the box.

I then made a tram, and setting one point at the outer edge of the felloe for a center, I struck a short arc on the end of the hub. This done at four opposite points, I took the center thus indicated for the center of my box, the same on both sides. The first wheel boxed by this method came very near exactness, which strengthened my faith materially, and I was confident that I had made an important discovery. I managed to suppress my joy, and kept on boxing, with no better results on an average than by the first method. A very short trial sufficed to satisfy me as to the merits of this plan, and a very little reflection showed me that the rim of a wheel, to be an infallible guide for this purpose, must be a perfect circle, and we all know that hand-made wheels are all guiltless of this quality.

Well, the end was not yet. I tried still another experiment, and the plan I next hit upon is the one I still pursue, believing it to be the nearest geometrically exact of any that can be devised at anything like the same expense. I made a very short sliding point to my tram, and put it between the other two (*a*, in the figure). Then

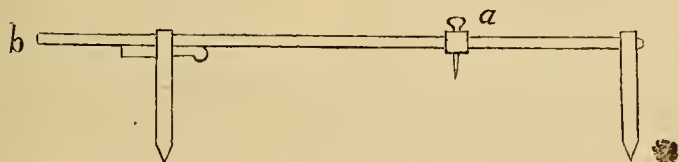

placing the end of the tram stick, *b*, against the hub right between two spokes, I adjusted the point *a* so as to strike a little arc on the rim of the wheel. Taking this mark for a center, instead of the outer edge of the rim, I proceeded with the tram as before. The result was most satisfactory, and ever since I have found my boxes very nearly true, when placed in the center of the hole made by this guide. The outside of a hub having been turned in a lathe is a perfect circle, and the four arcs made on the rim from the surface of the hub as a center, must also be in an exact circle; and again, from these a square is produced on the end of the hub, the center of which is easily fixed by the eye.

Suppose the hub to have shrunk since being turned, it being elliptical, the four arcs on the rim will also be in an ellipsis, and from them an oblong square is produced on the hub, the center of which is as easily fixed as though it were square, and the result is exactly the same. Suppose, again, the hub to be out of perpendicular with the rim, the result is still the same, as the longitudinal center of the hub, the place we start from, occupies the same position with reference to the rim, that it would if its axes were at right angles thereto, and, consequently, the arcs on the rim fall in the same place, and the square produced on the end of the hub agrees in all cases with the axis of the plane of the rim, right where we should locate the center of the box, whether the center of the hub is there or not. When we have done this, we have the box as near the center of the hub at both ends as is consistent with a true running wheel. If the hub stands askew, we have, by this method, placed the box one side of the center at one end of the hub, and the opposite side at the

other end, and at equal distances from it, and this is the best that can be done.

It is for the reasons above set forth that self-centering hub-boring machines, which bore for the box with reference to the hub only, have, of late years, had no place in my affections, much less in my shop. I care not how easily or expeditiously a machine bores a hub; if it makes the hole in the wrong place, it is simply a nuisance. When I see wagon-makers teach their apprentices to place the box in the center of the hub, and then wedge and try till the hub is ruined, and so on to the end of the ridiculous chapter, doing and teaching many things simply because their old boss did so—refusing themselves, and forbidding their apprentices to drink of the flood of light which is breaking upon the mechanical world—I feel, sometimes, as though the wagon shop was the chosen place where “old fogyism,” the common enemy of human progress, rears the most of her delectable family. Perhaps, I am unduly hardened; but, really, I do not feel bound, because my father bored his holes with a pod auger, and my mother worked her butter with her hands until it was oily, that my shop, or my dairy, must be conducted upon precisely the same plan.

## TALKING WAGONS.

BY HENRY HARPER.

Who has not heard the boastful exclamation, “my wagons talk,” from complaisant wagon-makers when they were recommending the good qualities of their wagons? It has been told me so often—and in fact been believed by me so long—as an indispensable qualification, that I can hardly reconcile myself to part with the old delusion. Nevertheless, although it will at first thought go against the generally received opinions of the craft, truth compels me to say that a greater absurdity never entered their minds. First, we ask in what possible way can a clattering noise, made by one part of the machinery in hitting against the other, help the motive-power of that machinery? In all other cases it retards the motion, and we are ready to acknowledge the same. Certainly a wagon is not a machine, exempt from mechanical laws.

The engineer who is regulating the motion of ponderous and complicated machinery would be started at once to attend to the duty of repairing the defective parts, if he should detect any clattering sound connected with its motion. The wagon is governed by the same laws of motion. All the difference between this heavy machinery and a wagon is that the former has had all its appliances more thoroughly studied and evenly balanced than the latter, so that the respective parts are capable of performing their offices without giving one part undue strength and heft over another part. Hence if a machinist should find a wheel slipping sideways on its axis, or any other part of the machinery slipping against the axis of the wheel, so as to make a noisy concussion, he would know that the motive-power of the machinery was being wasted, and that if he should supply that waste by additional motive-power, instead of removing the cause of the waste, he would be endangering the other parts of the machinery. This difference in his and our knowledge of the laws of motion does not speak very favorably of our education on a subject that is of vital importance to us as skilled artisans.

There perhaps has been no machinery ever invented of such importance as the wagon, and whose laws are so little understood. It has been thought so simple in its parts that no greater knowledge was necessary for its construction than we have by intuition, or at most what may be gained by legendary instruction. Hence we have in more instances than the one now under consideration received the greatest absurdities as facts, and cherished them, almost afraid to impart them to others, fearing they would know as much as we do.

When we ask for a reason why this clattering is beneficial to a wagon, some will say that it shows the wheel sliding from the shoulder to the point with such violence that it can be heard forty rods in some cases, and that demonstrates clearly that the wheel does not bind against the nut or the collar. Let us take the same wheel off from the axle and give it a good rolling motion with our hand, and then let it loose, we would see that its motion would be straight ahead, or on a gradual curve (no short angular side motion could be seen); therefore, if the axle was in the box, there would be no concussion between the nut or collar of the axle and the ends of the hub. The wheel was kept in motion after our hand was taken off from it by one of the laws of matter called "inertia"—an inability which all matter has of putting itself in motion or stopping itself after being put in motion; hence it went on in that steady forward course, and anything that would have diverted its forward motion would have retarded its progress. Therefore, if the wheel is diverted from its forward to an angular motion, so that it creates a rattling sound against the collar or nut of the axle, all the power expended to put it in operation has been diverted from a forward to a lateral motion, and finally expended itself in the concussion that it receives laterally. This would be no insignificant loss.

All ponderous bodies that have power expended on them to put them in motion are reservoirs for that power, and will render the most minute particle of that power back to overcome the obstacles to their motion. For instance, a span of horses are attached to a loaded wagon, but on the first start they will have to use all their strength for several moments to get the wagon in motion; after that, they may use no more power than is necessary to keep up the motion; but, should the pole of the wagon strike against a solid stump, it would probably break it; yet, if the horses should draw the end of the pole gradually against the stump, they could not break it. It was the latent motion received by the power the horses used in starting the wagon that was rendered back to overcome the obstacle, and that shivered the pole. When motion is stopped by two hard substances coming together, a noise is created by the concussion; therefore, we may know, when this noise comes from a lateral course, that it is wasting the motive-power to forward progression.

Another class of wagon-makers say that the noise is produced by the axles slipping through the boxes as the wagon gearing and load sways sideways, which shows that the wheels do not bind. If this was the case, it would present the same obstructions to the forward progress of the wagon that we have considered the wheels as having by lateral motion. But this class can practically test their theory by undertaking to carry a barrel half-full of water, and if the swaying of the liquid laterally helps their forward locomotion, it will be well to consider their arguments further; otherwise, it would be a waste of time.

Another class assert that *their* wheels are so evenly balanced that they do not know which way to fall, and their constant effort to get over one way and the other produces this constant click, click, click, or "talk." Let us examine this and see if there can be anything more absurd. We shall have to refer to Figure 1, to illustrate this case. The axle, A, rests on the box, BB, at the lower side. A spoke, S, extends from the box down, and rests on the ground, which supports it in a perpendicular position. The axle supports a load of 500 pounds; the box on the under side supports the axle; and the end of the spoke on the ground supports the whole weight resting perpendicularly on that spoke. It will be observed that the axle does not fill the box on the upper side, but there is a space between them the whole

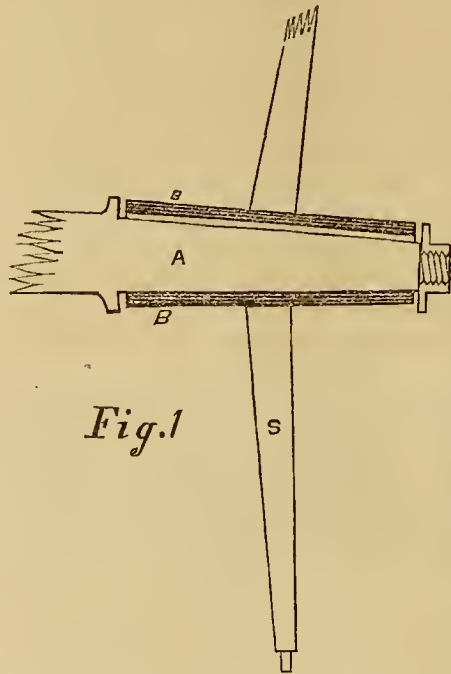

length of the box. This space extends down on each side of the axle, narrowing until it terminates on the bottom of the axle by the axle and box coming together. Now the question is, how are you going to get the top of this axle to hit the upper side of the box? If the axle is raised at either end of the arm, the wheel balances over from the bottom of the spoke that rests on the ground. There is no way of making them touch each other, only to raise the axle so high that the bottom of the wheel has extended out from a perpendicular beyond either end of the box. If the wheel inclines to fall over, as is asserted, it would have to balance 500 pounds on one end of the box, nothing on the other, which, of course, is an impossibility.

Then what makes this concussion sound? It has two causes which, generally combined, produce it; but either of the causes alone will produce it in a lesser degree. *It cannot exist in any case without being a serious detriment to the wagon in running easy, but the more we have of it the worse it is.* One cause, is in giving to the wheels what is called a "gather," that is, placing and holding the axis of the wheel so that the path of the tread to the wheels inclines to run together, while the axis is carried along in parallel lines. Strange as this may seem, it is an actual fact that a great many wagon-makers at this day think, that by sending the tread of the wheels in an angling path, and the hubs in a parallel path, that it helps them on their journey. The tread and the hub are made fast together, so one has to make a sideways move to keep in the other's path. The gather to the wheel is made by setting the points of the axles forward of a parallel position to each other; and as the path will be at right angles with the axes, they will run towards each other; and if nothing prevents them from following the path in which they are sent, they will cross each other's path, and, in

driving 50 miles, will get from 550 to 1,100 feet apart, depending, of course, upon the amount of gather (this would be scatter) that was given to them. This scatter is ingeniously prevented by making the wheels run sideways from 550 to 1,100 feet every day's drive of fifty miles. The wheels would be forced to slide sideways every time they were drawn forward the length of the axle-arm, just as much as the points of the axles are set forward. Say the axle-arms are six inches long, and they are set forward one-sixteenth of an inch (which is trifling gather), the tread of the wheels would be crowded into a sideway movement one-eighth of an inch every foot, which would make 55 feet to every mile that power is expended sufficient to draw the wagon sideways, over what is necessary to draw it forwards one mile. These are facts that can in no way be controverted.

This will be more easily understood by referring to Figure 2, which will show the course that a wagon will be propelled with or without a gather. The lines, A A,

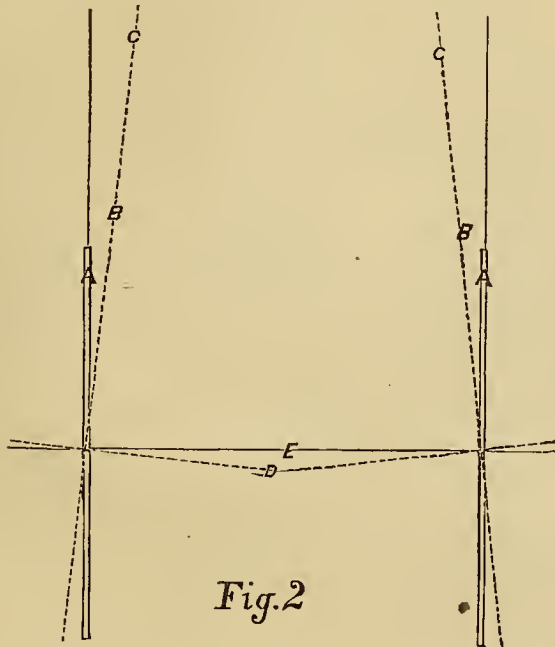

Fig. 2

are the wheels without a gather, and the line, E, is the axes of the AA wheels. Under all circumstances, the path of the wheel will be at right angles with the axes, consequently, if the axes are parallel, the path will also be parallel. It will be at once seen that this would be the most easy way to propel a wheel, because the force to propel is applied by the axle equally at each end of the axes, which keeps it in that right-angled course with the axes. This will be understood by attempting to force a long stick on the surface of water. If we apply the power directly in the line of the stick, it sends it in a straight line ahead; but if we apply more on one side than the other, the point of the stick will turn sideways, and the more it turns in that direction the greater the inclination will be to turn; so that, although we may have applied force enough to have sent the stick several rods ahead (if properly applied), yet, by this misapplication of force, it will only turn it around, presenting only the side in the direction we wished to send it. Applying the force to propel wheels equally on each side, and at right angles with a parallel path, forces them along in those parallel paths, without having to overcome any inclination to di-

verge apart or together, similar to that of the stick on the surface of water, which we have noticed.

The lines, B B, in Figure 2, will represent the gathered wheels and the path in which they are directed by setting forward the point of the axis, D. This arrangement would place the tread of the wheels at right angles with the axis, or D line, in the direction of C C. At the same time, the collar of the axles, which holds the hubs at equal distances apart, would carry the hubs along in parallel lines. Now, as we have said, the hub and rim of the wheel are trying to part company, the hub going in the direction of A, and the rim in the direction of C C; the tread of the wheel crowding the rim in, and the collar of the axle crowding the hub outwards. The collar, having more strength, will force the rim of the wheel to move sideways in the parallel paths of the hub. By this kind of movement power is expended for nothing. It amounts to just what the friction of the tread of the wheels makes in moving sideways into the parallel tracks, and the friction on the collars of the axle crowding them into the track. This varies on different roads. On rough, jolting roads, where the tread is not firmly fixed to the road at all times, it is least; on a smooth, plank road, it is greater; and the defect becomes so apparent, that the most stupid notice it, and admit that wheels should not be gathered for such roads. This is caused by the fact that the wheels are continually hugging the road, and cannot be crowded sideways without overcoming all the friction between the plank and the tread. The spokes of the wheel will sometimes bend so that the tread and track for a moment are accommodated to go in their respective paths, when the tread finally gives way, and the elasticity of the spokes, which have been bent, makes the bottom of the wheel fly out suddenly to the proper position that it sustains to the hub. Then comes a sudden volume of "talk" from a source silent before; then, again, the wheels are silent, until the same accumulation of force throws them off from the path again.

We believe that this binding force is felt more in sand than in any other place. There the felloes, being partly sunk, they must necessarily push through the sand, so as to be carried along in a parallel track. But evidently in any position that wagon may be used, either on rough, smooth, or sandy roads, up hill or down, or on a plane, in every case, it is one continued waste of motive-power, one continued drag on the team.

We have looked in vain for the causes generally assigned, as producing this clattering sound in wagons; we can make nothing more of it than to say, that, if reasons heretofore assigned are correct, it only proves that the concussion is a waste of motive-power, which all should strive to shun. A moment's reflection would have convinced us that even if there was a lateral movement of the wheel or the axle (from the nut to the shoulder), the distance would be so little—not more than  $\frac{1}{16}$  or  $\frac{1}{4}$  of an inch—that it could not gain momentum enough to produce the concussion. Still, there remains an undeniable fact, that wagons do make a rattling noise which would be very disagreeable, if we were not induced to think that it made the draught more easy. If we knew that this same noise was inconsistent with the easy draught of a wagon when heard, it would make us as nervous as it does an engineer to hear it in the motion of his engine. I do not feel as though I was running a risk of being charged with absurdity, when clinging to the idea that

Nature's laws are the same everywhere, and that a like cause will produce a like consequence; therefore, I unequivocally say, that instead of this noise being an indication that a wagon is running easy, it is the surest sign we can have that it does not run easy.

Reference to figure 2, will show the cause of this noise. If we take hold of the forward part of the wheel, A, we can crowd it towards the wheel, B, as much as the axle will permit it to go, and this will depend on how much smaller the axle is than the box. If it is small enough, we can turn it to B. This would make the axes of the axle lay cross-wise of the box, as we see the E line in the example of figure 2. Now turn to figure 3, which

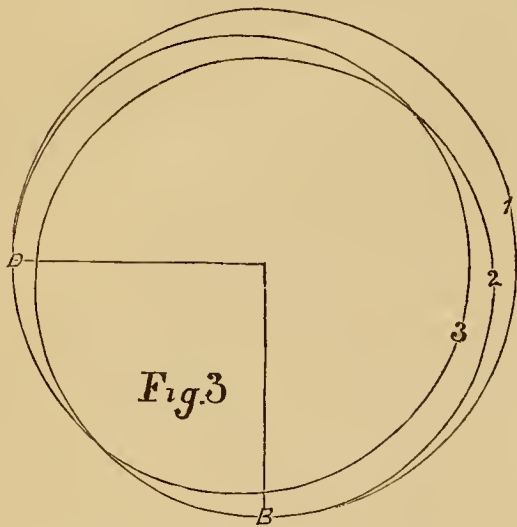

shows the ends of the box and axle, and the different positions in which the axle lays in the box, when the axes are straight with the box, and when they lay cross-wise. The circle, 1, represents the inside of the box, and, B, the bottom, D, the side. The circle, 2, represents the axle when the under-side lays on the bottom of the box, as is seen in figure 1. The circle, 3, represents the axle, when the axes lay cross-wise of the box, as we have seen in figure 2, occasioned by moving the forward side of the wheel from A to B.

Now it will be observed, that the axle, marked 3, does not hit the bottom of the box, nor the top; but that space, which we observe in figure 1, between the axle on the upper side and the box, is equally divided, and it touches the box in figure 3, at the side, D, on this end; but, on the other end, it touches the side of the box opposite from D. The corners of the box being circular, when crowded against the axle on opposite sides, lifts the axle up until it meets the circle that is over the axle, which is at D, and that prevents it from going any further. When the axle is suspended in this way between the top and bottom of the axle-box, of course the heft of the load has a tendency to bring the axle on to the bottom of the box, at B. The heavier the load the greater that tendency will be. It is a power of great force, which is continually seeking an opportunity to bring the wheel back into position, so that axle and axis of the wheel are parallel, and so that it can rest on the bottom of the box.

It is plain that the tread of the wheel forward of the axle, which is crowding the forward part of the wheel inward, and giving the wheel a strong tendency to twist around horizontally, as in figure 2, from A to B, makes

the axle lay cross-wise of the box like the E line.\* Being in that position, it is brought back the easiest, so that the axle can rest on the bottom of the box when the roads are a little rough. For instance, if the bottom of the wheel should rest on a small stone, as soon as that came perpendicularly under the axle, it would form a pivot for the wheel to swing back horizontally into position. The instant that it arrives in this favorable position, the heft bearing on the axle crowds down on the corners of the box; swings the wheel into position; and the axle falls into the bottom of the box; making, from concussion, a sound; sometimes by the collar of the axle hitting against the box; sometimes the nut, and possibly the axle falling into the bottom of the box, with the heft of the load on it, may make some noise. A person sitting on the load at this instant, will feel as though the wagon was moving easier, and this fact may have induced some to think that the wagon moves easier when they hear the "click" of the wheel. In fact, it does move easier for an instant; because it has relieved itself from the cramped position of the axle and box which we have just described; but, it is only for an instant; the wheel starts along in the same path, which has the same effect to bring the wheel cross-wise with the box which produces the same noise and the same consequences, all of which we are notified of by the "clicking" sound which we have wrongfully supposed was the wheel hitting against the collar or nut by a lateral movement.

We will admit, that the more we hear of that sound, the oftener the wagon is relieved. On a smooth plank road we do not hear it so often, because there are not so many elevations to make a pivot on which to swing the wheel horizontally into position, and it is a notorious fact that we cannot find a man of any experience on plank roads, who will recommend a gather to the wheels for such. The consequence is, that instead of the wheels often getting into position, they turn around for some time with the axle crossing the axis of the wheel, which more inclines it to turn in, until the wheel really begins to bend from the pressure, when it finally comes to a spot that will let it fall into position; it then comes back with all the force that the strain and elasticity of the spokes, together with the force of the axle, can make it. All agree that this is not the right kind of a noise, yet it is the effect of the same cause; all the difference is, that the wagon on one road relieves itself from a wrong position oftener than it does on another.

It is a good thing when a wagon gets into a bad position to have it helped out; but it is a far better thing—

\* Since writing the above, we have found the most conclusive proofs that can be adduced, to maintain the position advanced. A thimble-skeined wagon, that was about one-fourth worn out, was brought to the shop to have the axles repaired. On examination, the skeins were found to be worn through the cast-iron near the collar, *but back of the bottom of the skein*. At the point of the skeins, the wear was reversed, so that the most of it was *forward of the bottom of the skein*. All of the skeins on the wagon had this peculiarity. This showed positively by the wear, that the axle had layed cross-wise of the box, to wear itself into that shape. The wagon had been used as an express wagon, running about seventy miles and back at one trip. The road was sandy loam, and considerably traveled by wagons. Of course the tracks that the wheels run in, would be parallel lines, and would form ruts that would be parallel. These ruts would hold the wheel, so that the tread would follow their course in parallel line. It was found on inquiry of the man who built the wagon, that the axles had been made with a gather; consequently, holding the wheels in parallel paths, would make the axle lay cross-wise of the box, and cause the wear at the shoulder to be on the back-side of the axle and reversed at the point.

Such lessons had ought to be better improved than they are by old "fogies," who will still cling to the old senseless notions about wagons. The man who knows enough to turn a grind-stone, knows that the faster the iron which he is grinding is cut away, the harder it will be to turn the stone; but there are some of the craft that live and die without learning as much about wagons.



when it is just as easy—to construct it so that it will keep out of the bad position. This can be done by simply making the wheels run parallel to each other, and by balancing them so that the pressure is equal on each end of the axle.

If we take hold of either the hind or forward part of a wheel, and twist it around horizontally, back and forward, we thereby produce the same clattering noise. Can any one doubt, but that twisting the wheel horizontally on the axle, brought the box of the wheel and axle crosswise as we have described it, and that the collar of the axle and the nut hitting on the box made the noise? Or, can any one doubt that if the wheel is moved in that way at any time or under any circumstances, that it will not make that same noise in the same way? Certainly it will, unless the collar and nut are muffled by a leather washer, as is done on our best axles. If we raise the axle of a wagon up so that the felly will not touch the ground, and then draw the wheel straight from the collar to the nut, pushing it back towards the collar  $\frac{1}{8}$  or  $\frac{1}{4}$  of an inch—whatever the space may be—it will not make a noise like that of the “talking” wagon.

If we take hold of the top of a wheel to a loaded wagon and push it sideways, so as to raise either end of the axle off from the box, we must use enough force to lift the load resting on the wheel. To be sure there will be a lever-power to do it with; but in some cases, it would require one-half the heft of the load to work the lever. The heft of the load keeps the wheel from any motion of the top sideways, unless the axle goes with it; therefore, the collar and nut preserve the same relative position, and cannot strike against the box by any movement in that direction. Every way that we view the case, points invariably to the conclusion, that the noise that so generally has been considered so good a sign, in a wagon, is occasioned by the wheel turning crosswise to the axle and then flying back into place again.

The other cause of the concussion between the axle and box is occasioned from not balancing the load evenly on the shoulder and points of the axle-arm. For instance, in figure 1, if the axle lays on the bottom of the box with an equal pressure at both ends, this forms the strongest resistance that can be made in the case to the tendency that may be given to the wheel to twist around horizontally. But let us take the pressure mostly off from the point of the axle, and put in on the collar end, then the point of the axle not confining the box by the pressure on it, would allow the point of it to turn around the collar until it was stopped by the collar or nut hitting against the box, which would produce the noise. This will be the least noise, and is regarded by those who do not give these axles a gather, as the right kind of sound.

The programme is so arranged, that two parties claim a *real and most serious defect in their wagons*, as a sure sign of their superiority. The one who has the two defects combined, says, “*I tell you what, sir, my wagons ‘talk,’ so that you can hear them half a mile.*” The other party says, “that is not the right kind of talk.” A wagon should *only make enough noise* to assure you the wheels are playing back and forward from the collar to the nut, so that they do not bind.” How strange this talk would sound from an engineer who was demonstrating the even motion that a heavy balance-wheel was making in some well-regulated machinery. Yet it would be just as sensible in the latter as in the two first cases.

Theory explains the cause and the consequences of the noise made by wagon-wheels in certain cases; but a practical test will not come amiss. This has been thoroughly tested in certain places, where I have felt the greatest interest in observing the results. They are as follows, with heavy draught-wagons:

Wagons with the bearings unequal, and the wheels gathered a little, made the most noise in running. Wagons with the bearings as nearly equal as can be made by guess (which is often far from equal), and without any gather, make less noise. Wagons where the bearings were made equal by measurement which does not admit of a doubt, and where the axles are set without a gather, will run on an ordinary level road with scarcely any noise at the axle-box. Those who use the latter class of wagons think they have some superior qualifications for running; so much so, that they will go many miles further to have an axle set at the place where they are sure of having such work done perfectly.

The question is of importance—more than the value of any wagon depends on this indication—whether it will make this “click” “click” “clicking” noise, called “talk,” when the wheels are revolving, or whether they will run steadily without any noise. Of course we do not mean that a leather muffler, in the shape of a washer deadening the noise, is any indication of an easy running wagon; but where the iron of the axle and box are allowed to come freely in contact and then not make any noise. As has been said at the commencement of this article, wagon-makers have generally had their minds made up that there must be some noise either in a greater or less degree, different from that of other kinds of machinery, to indicate a good running wagon. My mind was formed to that conclusion without any philosophical reasoning, because a great many supposed good mechanics said that it was so. My observation on the subject has been very extensive—perhaps more so than that of a great many other mechanics—and I can assert most positively, that I never have become acquainted with a mechanic so stupid but that he could, and did make the very best running wagons if that was a test.

The thinking mechanics have, of late years, discarded the old notion of gathering the wheels, and that makes them noiseless, and for that reason they are not so anxious to insist on it as a test, except in a modified degree.

Practical experiments made by building wagons in the way which philosophical and reasoning mechanics have agreed upon as the best—that is, without any gather, and with the wheels evenly balanced, so that the weight bears equally on the shoulder and the point of the axle—has disclosed this most important fact, that the effect is just the same as it would be in any other well-regulated machinery. These run even and steady, making scarcely any noise by the axle, collar, nut, or any other part in hitting against the box.

The difficulty that has been in the way of demonstrating this fact long ago, is, that we have been deceived in getting a mathematically correct scale for balancing the wheels correctly on the axle-arms. To make the axle-arms parallel in every case, has been a comparatively easy task, or to give them a certain gather. But to get the wheels on the exact balance, would require every axle-arm on a wagon to be pitched different in many cases. We have deceived ourselves in supposing that we have had mathematically correct ways for performing this

delicate operation. I imagine that there are hundreds who will deny this assertion—but I will bring ninety-nine truthful witnesses out of every one hundred wagons that can be produced, to establish the fact as I have asserted. Every person that knows anything about a wagon, knows that there is a difference in their running qualifications. It is a curious arrangement for the incompetent mechanic to establish as a standard, the worst features in a wagon as being the best. This virtually places him at the head of the profession!

If there can be a true standard fixed so that the un-mechanical purchasers of wagons can judge of the right from the wrong without being obliged to study a treatise on the subject, it will do more than anything else to protect them from imposition, and advance the real interests of the trade.

The mechanic should do the studying to inform himself on a subject that he is paid for. It would be a good thing if the world could have those pointed out who are paid for studying what they never practice, and the intolerable injury they are suffering from dishonesty.

## Pen Illustrations of the Drafts.

### DEPÔT WAGON.

*Illustrated on Plate XLIV.*

FOR a vehicle intended for private convenience, when going to the railroad depôt, we think this the best ever contrived. The two seats (one is hidden by the curtain) are made to slide on a rail, on the inside of the body, or may be taken out as necessity may require, in stowing trunks or other baggage. The top, made to shift, is formed of three bows, and roofed with slats running parallel with the body, and further strengthened with short ribs between the bows, 3 in all. These are covered with India-rubber cloth; the curtains enameled leather.

A few details are added for the convenience of the builder; body, 5 ft. 9 inches long, and 4 ft. 1 inch in width, with a side panel of  $\frac{1}{2}$  inch cherry, 8 inches deep; wheels, 4 ft. 2 inches, and 3 ft. 11 inches in height; rims,  $1\frac{1}{8}$ ; tire,  $1 \times \frac{1}{4}$ ; hubs,  $4\frac{1}{2} \times 7$  inches; spokes,  $1\frac{1}{8}$  inches; axles,  $1\frac{1}{8}$  inches; springs,  $1\frac{1}{2} \times 3$  inches; steel, four leaf front, five leaf back, and 3 ft. 6 inches in length.

### BRACKETED COAL-BOX.

*Illustrated on Plate XLV.*

WE think this species of buggy finds more admirers this season than they did formerly. A prejudice once existed against them, as looking rather foppish; but that idea seems, in a degree, to have died away, and now they are found very fashionable on the thoroughfares leading from the lower parts of this city to the uptown resorts. The details for making these buggies (all buggies are much the same) are so well understood, generally, that we may well be excused from swelling our remarks in giving them.

### CANED BUGGY.

*Illustrated on Plate XLVI.*

PERHAPS many of our readers will find it very difficult to finish a buggy after the sham-caned order. We need not say to such, that a buggy of this description will look well enough, plainly, but well painted in the usual manner.

## Sparks from the Anvil.

### FORE-CARRIAGE FOR A PHÆTON.

OUR engraving shows a bird's-eye view of a very unique plan for the fore-carriage of phætons, coupés, and other vehicles constructed with perches. The mechanic

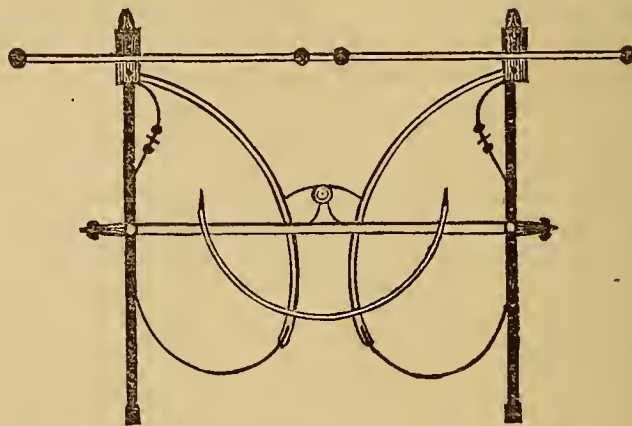

will understand that only the underpart of the carriage is here given, showing the arrangement of the iron-work very distinctly.

## Paint Room.

### COMPOSITION OF PAINTS.

BY H. HARPER.

*(Continued from Page 156.)*

Linseed and paint-oils considered—How linseed-oil is obtained from the flax-seed—Meal cake—Rape seed—Conclusions in regard to oils.

WHILE we are on the subject of adulterating oil, we cannot let it pass without noticing raw oil, which, from the fact of the disproportional low price at which some paint-oils are offered, compared with flax-seed, out of which the genuine is made, and the almost entire absence of the smell or taste of flaxseed in the so-called paint oils, without the inference that flax-seed does not enter much into the composition. What we do say must necessarily be founded on supposition, for we are free to confess that we are at a loss whether we should speak well or ill of the new compound, or of what it is made. We can give our opinion, as we did on a former occasion when we supposed that it was adulterated with benzine, and a year hence may be ready to retract that opinion.

When we have briefly examined the process for making flax-seed oil in connection with its component parts of glue and oil—which we have noticed in the preceding article—it will explain why we are at a loss about pro-

nouncing the change a good or bad one. I have had only one opportunity of seeing oil made, and shall pretend to give such of the details as have a bearing on my theory regarding the present composition of oil.

The flaxseed is crushed into meal by putting 8 or 10 bushels at a time, into a circular groove or trough about 14 inches wide, and then rolling a large stone wheel, made to fit the groove, around in the circle until the seed is converted into meal. The meal is then put into an iron cylinder revolving over a fire, and there turned until the meal becomes heated. From this, while hot, the meal is put into a hoop, and subjected to one of the most powerful of lever and screw presses combined. After the oil is pressed out, the meal is formed into a hard cake by the pressure, and subjected to another mashing, heating, and pressing process. The two pressings the meal gets separates the oil from the meal, but a large proportion of the glue remains in the meal-cake. It seems, when the oil is pressed from the meal, it will hold only a certain part of the glue in solution, for it is certain that there is a large proportion left in the meal-cake. If the cake is dissolved in water, it forms a strong gluey mucilage, which is well adapted, in painting, to such places as where a glue coat is required.

Now I am very much disposed to think, in the process of manufacturing linseed-oil, that if any other oil which was not volatile, and had a drying quality, yet lacked the glue, was mixed with the flaxseed meal, and pressed out in the usual form of pressing the meal, that it would take into its composition a portion of this superfluous glue that would otherwise be left in the meal-cake. By that means it would form artificially the same compound as linseed-oil. For instance, if we should take corn-oil, which is cheaper than flaxseed, and which would be worth, less separate, for the want of the glue, and treat it as we have indicated, would it not make good paint oil? There are some stubborn facts to be accounted for which we can give no other solution.

The first is, that when flaxseed commands \$3 per bushel, the oil that one bushel would make at \$1.50 per gallon, would just pay for the seed, or, certainly, not any more. Manufacturers could not manufacture it for the cake, nor are they disposed to work for nothing. Second, this oil has very little the smell or taste of flaxseed. When we first discovered this last peculiarity, our prejudices were excited against it, but we could not help ourselves, because it had generally got introduced, and all the satisfaction that we could get by complaining about it to the dealers was, that the difference was occasioned by foul stuff that sometimes grows among flax, called "rape." For my part, I did not know what "rapeseed" was, nor could I get any way enlightened, only that it was a weed that grew among flax, and was full of oil. I have found out since that there was such a weed, but the idea that it was so plentiful as to give a peculiarity to all the oil made, is entirely preposterous. It is carefully excluded from flax, because it spoils the crop; and from the appearance, it does not contain any more oil than pig-weed seed, certainly the yield is not as great. The effects of the supposed evil which we could not avoid, has been carefully examined to detect and point it out if there was anything wrong. For my part, after this examination, together with my prejudices, I cannot say but that our raw oil lasts as well as ever it did. Boiled oil that is sold in the shops, we unhesitatingly pronounce worthless,

because, if there is an exception, we cannot distinguish the good from the bad by appearances.

It is a matter of congratulation, if manufacturers of linseed-oil have hit upon a process of making it as good, and at the same time cheapening the article. At any rate, they have gone so far and so successfully with it, that they will not soon be ready to retrace their steps unless there is some very obvious reason for it. If as good, there is no reason for keeping the actual composition of it longer a secret. If they intended to deceive at first, the intended deception has become a reality. Now it would be of great importance to the consumers of oil, if they knew the real facts in relation to it from the manufacturers; and as there are so many who must understand all about it, we trust, at no distant day, that some one will be good enough to enlighten us on this subject.

[We have just had sent us a circular of the Patent Paint Oil, "a substitute for linseed-oil," in which we find that "this oil has now been in use for over a year, on inside and outside work; also extensively on boats and ships; and wherever properly applied, is found to resist the changes of weather, and to be unaffected by salt water, and fully equal to boiled oil, costing less than one-half the price of linseed-oil." We advise our readers to stick to the pure linseed-oil for the present, and thereby avoid trouble. Linseed-oil is now selling by the gallon, wholesale, for \$1.55 @ 1.58. Linseed cake: city, in barrels, at \$53 @ \$55 per ton, of 2,000 lbs.; in bags, at \$48 @ \$50 per ton, of 2,000 lbs.; western, in bags, at \$48.—ED.]

## Trimming Room.

### THE FASHIONS.

ALL, or nearly all, the buggies made for city customers are trimmed inside with blue cloth linings, the falls and fronts of the cushions having chord insertings, which are afterwards machine-stitched along the edges, instead of patent leather weltings as was formerly done. This, well done, looks tasty and neat. When other fancy linings are used, it is to satisfy the whim of some "fancy man," and may be called an exception to the general practice. The same process prepares a band for the finish inside of tops made with "take-off" curtains; but neither sun-curtains nor festoon-fringes find any favor now. If anything is used (which is seldom), a *curtain* is made by "pinking," of the same material as the head-lining. There is certainly some advantage here, for if one fades with the other, they still look uniform—a condition never found where silk and cloth unite. Our Price List shows that prices for cloths are still advancing.

### HARNESS BLACKING.

WE have given several recipes for harness blacking in these volumes. We now give two more:

Melt together, 8 oz. of beeswax, and one ounce of oil-of-turpentine; add 2 oz. ivory black, 1 oz. Prussian blue, and  $\frac{1}{4}$  oz. copal varnish. Apply with a brush and polish with a duster.

Again: Take isinglass or gelatine and indigo, of each,  $\frac{1}{4}$  oz.; logwood, 4 oz.; soft soap, 2 oz.; glue, 4 oz.; vinegar, 1 pint; mix, heat, and then strain the ingredients.

## Editor's Work-bench.

### TO OUR READERS.

WITH this number we complete the fifth volume of THE NEW YORK COACH-MAKER'S MAGAZINE, and have discharged our obligations to that portion of the craft who have lent us their aid. To those who have stood by us until now, we return our heartfelt thanks, and hope still to have their patronage; and we also trust that many others, who felt themselves too poor in harder times, will give us their support during the publication of the sixth volume, commencing with June next.

Since the commencement of our national difficulties, three years ago, as all our friends know, almost everything connected with literature has been steadily advancing, until now the costs of publication are double or nearly so. That our readers may judge of our situation, for themselves, we will state that paper, such as we formerly used, cost us 12½ cents per pound; the same, to-day, is worth 25 cents, and difficult to obtain at that price. Composition (that is setting the type), for which we used to pay 40 cents per 1,000 ems, now costs us 70 cents. A page of this Magazine contains about 3,500 ems. The press-work (inside pages) then cost us 40 cents per token (a token is 250 sheets), now 80 cents; tints formerly cost \$1 per token, now we pay \$1.50; printing the engravings on the plates, once was done for 75 cents, now we are charged \$1.75. These are plain statements, showing that our expenses in production are about doubled. Such being the case, we have reached a point where we are compelled, by the force of circumstances, to advance the price of subscriptions for the coming volume to \$5, making a liberal discount to clubs. Single numbers will be 50 cents each. Even at these prices, we do not expect to make enough to pay for the time and labor involved in editing.

One very important source of profit with us has been almost entirely cut off—we allude to that of advertisements. Very few of the dealers, or manufacturers of carriage materials, would think it advantageous for them to advertise their wares now. They tell us they have more orders than they can possibly fill with the present scarcity of labor, and we have no doubt this is so.

Our Magazine was started with the expectation of obtaining a large circulation, and although expensively got up, was always furnished at a low figure for a publication of the kind. Compare ours with the sickly-looking French *Mercuré Universel*, of 4 pages letter-press and two plate abortions, for which \$9 are charged, and tell us if ours is not cheap at \$5. Even at a higher charge than this, the English periodical "went under." It is only by indomitable perseverance and a will to succeed, that we are able to-day to say that THE NEW YORK COACH-

MAKER'S MAGAZINE still lives. Whether it lives beyond the sixth volume, or not, will depend upon the support its real friends accord to it the coming year. For our own part, we intend that the future volume shall not be inferior to any which have preceded it, and that it shall be all that industry and experience can produce—something satisfactory to the public, if possible.

In conclusion, we intend, as soon as circumstances permit, to reduce our terms to the old standard, and still offer the first, second, third and fourth volumes at the old prices; the fifth (a few copies of which remain), in numbers, for \$4, or bound, for \$5. We ask it as a special favor, that our friends would early renew their subscriptions, that we may with some certainty determine about how many copies will be required to supply all demands that may be made upon us. All subscriptions, not renewed, terminate with the period to which they are paid.

### OMNIBUSES vs. THE PUBLIC.

THAT old phrase, "there is always room for one more in an omnibus," is in a fair way to become obsolete, since the New York stage proprietors have, at one step, advanced their fares from six to ten cents on the principal routes. They now travel nearly empty, and the word is, "plenty of room for several more." We understand, that at the old price, stage proprietors have always found the business a paying one; but the great advance in fare, now made with a strong opposition from horse rail-cars running all over the city, will operate to their injury. The following about expresses the public opinion:

*To the Editor of the N. Y. Tribune.*

SIR: The jump from six cents to ten, in the price of fare, is altogether too steep for the pensive public. For one, I do not mean to put up with it, and although both lame and lazy, I will not enter one of the mercenary vehicles again while this preposterous new tariff remains in force. Let the huge army of city travelers who usually ride in an omnibus, follow my example, and it may bring the proprietors to their reason by depleting their pockets.

April 12, 1864.

LAZARUS.

The Broadway lines seem determined to carry matters as far as possible in this respect, since they have succeeded in defeating all attempts to run a line of cars through that crowded thoroughfare. We suggest, however, that their recent action in extorting money from the traveling portion of the public for trusting themselves in their "old rattle boxes," is well calculated to bring about that against which their owners have thus far so strenuously and successfully contended. We shall see.

### EDITORIAL CHIPS AND SHAVINGS.

LIVERY STABLE INCREASE IN CARRIAGE FARE.—The livery stable keepers of the city of New York have combined and fixed a uniform scale of prices for the hire of carriages, commensurate with the times. It was shown at a meeting, recently, that oats, formerly bought for 38 cents per bushel, now cost them 92 @ 95 cents; hay, formerly 45 cents per hundred, now costs \$1.50; fine feed,

formerly 45 cents per bag, now \$1.90; straw, formerly 40 cents per hundred, now \$1.10 per hundred bundles; cornmeal, formerly 90 cents per bag, now \$2.40; carriages, which formerly cost \$6.50 to \$6.75, can now scarcely be bought for \$1,150; hack harness, once costing \$70, now costs \$125 per set; and hostlers and drivers are asking \$35 and \$40 per month. In view of these facts, the livery stable keepers have adopted the following scale of prices:—funeral calls, \$6; railroad and boats, \$1.50; price to boats below Cortlandt street, \$2.50; party calls, \$3; and by the hour, \$1.50.

### The Coach-maker's Letter-box.

THE following letter has greatly cheered us in our labors. Showing, as it does, the right kind of friendship, we publish it that others may see how much may be done with a little effort, and as an incentive for others to do likewise:

AURORA, ILL., APRIL 14, 1864.

E. M. STRATTON, Esq.—*Dear Sir,*—In response to your call for an addition to your subscription list, I have the no small satisfaction to report that I have raised a club of ten subscribers in this place, with very little trouble—seven of them are employés of one firm. As soon as their pay-day comes off—in two weeks—I will forward their names with the money. I am sure if one of your subscribers in every town will take the few steps that I have for his Magazine, it will not stop for want of patronage. I should regret exceedingly to see you compelled to suspend publication, for there is no paper that begins to take its place. The "Scientific American" comes the nearest to it, probably; but as a journal of popular science, it is impossible for that paper to give us a fair hearing. We must sustain a periodical that gives us specialities, and the minute particulars in construction, and the latest styles and inventions, with the market prices of material, and thereby afford the leading spirits of the fraternity an opportunity for a free interchange of views, that old fallacies may be helped out of existence as expeditiously as possible. I am one of those who desire to see the wagon elevated from the home-made implement of former days to the dignity of the machine, and our trade with all other mechanical pursuits, raised to the rank and respectability of the professions; and I would call upon my fellow-craftsmen all to assist in sustaining the one who represents as ably, as you do, our interests in the press. In the sincere hope that you may get, within the next month, such accessions to your subscription list as to afford ample encouragement to continue our paper,

I remain, yours truly,

O. E. MILES.

### FOREIGN IMPROVEMENTS IN CARRIAGES.

APPARATUS TO FACILITATE THE CONNECTING AND DISCONNECTING HORSES AND OTHER ANIMALS WITH CARRIAGES.—July 13, 1863. C. Opperman. This invention is carried out as follows:—In the case where shafts are used, the traces, when placed in position, will be retained by hooks or studs, each of which is affixed to, or capable of turning on an axis, and of being retained in position by

a spring lever and stop, or stops; another stud or stop prevents the traces slipping off the movable hook or stud, except when required. In the case of poles being used, the inventor connects the pole chain from the collar or breastpad of each horse or other animal to the pole, by passing it over a stud, or projection, and securing it there by a sliding plate or bar, which is capable of being held in position to retain the pole chains by a retaining screw or catch, or other suitable holders; the removal or releasing of which, will admit of either or both of the chains being released. Or the hooks or studs, carried by the pole to receive the ends of the pole chains, may be, together or separately, capable of turning on an axis of motion, so as to release their ends and allow of the chains dropping off and they are retained in position by a catch or stop. These parts are also applicable to pole straps, and to the connection of pole chains or straps, with the collar or breastpad. He also forms a hook adapted to be used as the connecting means for the pole chains or other parts of the harness, to facilitate connection and disconnection of such parts—not proceeded with.

### AMERICAN PATENTED INVENTIONS.

Feb. 23. SELF-ACTING SLED-BRAKE.—Calvin E. Myers, Bristol, Vt.: I claim, *First*, the combination of the sliding frame, E, draft-pole, F, and dogs, HH, all constructed, arranged, and operating in the manner and for the purpose set forth. *Second*, in combination with the above, I claim the hook, I, and eye, h, for preventing the movement of the frame, E, as explained.

LIFTING-JACK.—Ebenezer Young, Camden Center, Mich.: I claim the lever, C, provided with oblong slots, c, having notches, d, at its outer end, in combination with the ball, D, and a suitable frame in which the lever, C, is fitted: all arranged to operate substantially in the manner and for the purpose herein set forth.

March 1. CARRIAGE.—Edward France, Cobleskill, N. Y.: I claim, *First*, in combination with two bolts operating in unison as described, the herein-described spring mechanism for the automatic locking or unlocking of the shafts, as set forth. *Second*, the combination of two bolts coupled as before referred to, and spring mechanism arranged to operate as described, with a ratchet and pawl for locking the bolts, substantially as herein set forth. *Third*, combining with the bolts and spring, a pawl and ratchet so arranged or located, as that it may be readily actuated to release the spring ratchet, and effect the unlocking of the shafts, substantially as herein set forth. *Fourth*, the method of locking the wheel-plate or fifth wheel, by operating the spring ratchet for the purpose of steadying the course of the vehicle, substantially as herein set forth.

### CANADIAN PATENTS IN CARRIAGES.

July 2, 1863. ANDERSON'S GIG.—James E. Anderson, blacksmith, of the town of Port Dover, in the County of Norfolk, patentee.

31. WAGON-BOX.—Levi V. Bowerman, Farmer, of Hallowell, in the County of Prince Edward, patentee.

Aug. 3. SULKEY AND SEAT SPRING.—George Byron Birce, Blacksmith, of Ingersoll, in the County of Oxford, patentee.

22. SHRINKING WAGON TIRES.—William R. Bowen, Machinist, of the town of Haldimand, in the County of Northumberland, patentee.

Nov. 2. IRON AXLE-TREE.—Robert Highet, Ironmonger, of the town of Cobourg, in the County of Northumberland, to be called Highet's improved patent iron axle-tree.

5. DOUBLE SINGLE-TREE.—Wm. W. Kitchen, Yeoman, of the township of Grimsby, in the County of Lincoln, patentee.

Dec. 16. SAFETY-RUNNER FOR WINTER VEHICLES.—Aime N. N. Aubin, Esquire, of Belœil, in the County of Vercheres, patentee.

## CURRENT PRICES FOR CARRIAGE MATERIALS.

NEW YORK, April 20th, 1864.

Apron hooks and rings, per gross, \$1.25.  
 Axle-clips, according to length, per dozen, 75c. a \$1.25  
 Axles, common (long stock), per lb, 11½c.  
 Axles, plain taper, from ¾ to 1 in., \$6; 1½ in., \$6.50; 1¾ in., \$7.  
 Do. Swelled taper, 1 in. and under, \$6; 1½ in., \$7; 1¾ in., \$8.50; 1¾ in., \$10; 1¾ in., \$12.  
 ☞ These are a superior axle, and more frequently called for than any others.  
 Do. case-hardened, half-patent, 1½ in., \$7; ¾ in., \$7.50; 1¾ in., \$8.50; 1¾ in., \$9.  
 ☞ These are prices for first-class axles. Makers of less repute, cheaper.  
 Bands, plated rim, under 3 in., \$2; over 3 in., \$2.50.  
 Do. Mail patent, \$2.50 a \$3.75.  
 Do. galvanized, 3½ in. and under, \$1; larger, \$1 a \$2.  
 Basket wood imitations, per foot, \$1.  
 ☞ When sent by express, \$2 for a lining board to a panel of 12 ft.  
 Bent poles, each \$1.25.  
 Do. rims, under 1½ in., \$2.25 per set; extra hickory, \$2.50 a 3.50.  
 Do. seat rails, 44c. each, or \$4.50 per doz.  
 Do. shafts, \$6. a \$7.  
 Bows, per set, light, 90c.; heavy, \$1.25.  
 Bolts, Philadelphia, at new list.  
 Do. T, per 100, \$3 a \$3.50.  
 Do. tire, \$1.25 a \$1.80 a \$2.40, according to size.  
 Buckram, per yard, 30c. to 35c.  
 Buckles, per gross, 88c. a \$1.25.  
 Burlap, per yard, 25c.  
 Buttons, japanned, per paper, 20c.; per large gross, \$2.25.  
 Carriage-parts, buggy, carved, \$4 a \$5.  
 Carpets, Brussels, per yard, \$2; velvet, \$2.75 a \$3.75; oil-cloth, 70c. a 90c.  
 Castings, malleable iron, per lb, 15c.  
 Clip-kingbolts, each, 35c.  
 Cloths, body, \$3.75 a \$5.50; lining, \$2.50 a \$3.50. (See *Enameled*.)  
 ☞ A Union cloth, made expressly for carriages, and warranted not to fade, can be furnished for \$2.25 a \$2.50 per yard.  
 Cord, seaming, per lb, 35c.; netting, per yard, 5c.  
 Cotelines, per yard, \$6 a \$8.  
 Curtain frames, per dozen, \$1 a \$1.50.  
 Do. rollers, each, \$1 a \$1.25.  
 Dashes, buggy, \$1.75.  
 Door-handles, stiff, 50c. a 63c.; coach drop, per pair, \$2 a \$3.50.  
 Drugget, felt, \$1.62.  
 Enameled cloth, 5 qrs., 75c.; 50 in., \$1.55.  
 Enameled cloth ranges from 80c. to \$1.55, according to width and quality.  
 Enameled linen duck, 4 qrs., 55c.; 5 qrs., 75c.; 52 in., 90c. Colored, 15c. higher per yard.  
 Felloe plates, wrought, per lb, all sizes, 20c.  
 Fifth-wheels wrought, \$1.38 a \$2.  
 Fringes, festoon, per piece, \$2; narrow, per yard, 18c.  
 ☞ For a buggy top two pieces are required, and sometimes three.  
 Do. silk bullion, per yard, 35c. a 75c.  
 Do. worsted bullion, 4 in. deep, 35c.  
 Do. worsted carpet, per yard, 6c. a 10c.  
 Frogs, 50c. per pair, or \$1.63 per dozen.  
 Glue, per lb, 25c.  
 Hair, picked, per lb, 30c. a 60c.  
 Hubs, light, morticed, \$1; unmorticed, 75c.—coach, morticed, \$1.50  
 Japan, per gallon, \$4.75.  
 Knobs, English, \$1.75 a \$2.  
 Laces, broad, silk, per yard, 85c.; narrow, 12c. to 15c.  
 Do. broad, worsted, per yard, 37½c.  
 Lamps, coach, \$14 a 18.  
 Lazy-backs, \$9 per doz.  
 Leather, collar, dash, 31c.; split do., 18c. a 31c.; enameled top, 31c.; harness, per lb, 55c.; flap, per foot, 25c. a 30c.  
 Linen, heavy, a new article for roofs of coaches, 60c. a 90c. per yard.  
 Moquet, 1½ yards wide, per yard, \$7.  
 Moss, per bale, 10c.  
 Mouldings, plated, per foot, 12c. a 15c.; lead, door, per piece, 30c.  
 Nails, lining, silver, per paper, 8c.; ivory, per gross, 31c.  
 Name-plates.  
 ☞ See advertisement under this head on 3d page of cover.  
 Oils, boiled, per gallon, \$2.75.  
 Paints. White lead, extra, per 25 lb \$3.95; Eng. pat. black, 31c.  
 Pekin cloth, per yard, \$4.50.  
 ☞ A very good article for inside coach linings.  
 Plushes, per yard, \$2 a \$3.

Pole-crabs, silver, \$5 a \$6; tips, \$1.25.  
 Pole-eyes, (S) No. 1, \$2.50; No. 2, \$2.65; No. 3, \$2.90; No. 4, \$4, per pr.  
 Sand paper, per ream, \$4.50.  
 Screws, gimlet.  
 ☞ Add to manufacturer's printed lists 20 per ct.  
 Do. ivory headed, per dozen, 38c. per gross, \$4.  
 Serims (for canvassing), 23c. a 25c.  
 Seats, buggy, pieced rails, \$1.75; solid rails, \$2.50.  
 Shaft-jacks (M. S. & S.'s), \$2.62; light, \$3.00; heavy, \$3.30. a \$4.50.  
 Shaft jacks, common, \$1.12½ per pair.  
 Do. tips, extra plated, per pair, 35c. a 50.  
 Silk, curtain, per yard, \$1 a \$2.50.  
 Slat-irons, wrought, per pair, 75c.  
 Slides, ivory, white and black, per doz., \$12; bone, per doz., \$1.50; No. 18, \$1.75 per doz.  
 Speaking tubes, each, \$6.50.  
 Spindles, seat, per 100, \$1 a \$1.25.  
 Spring-bars, carved, per pair, \$1.25.  
 Springs, best temp. Swedes, per lb, 29c. a 30c.; black, 22c.; bright, 23c.; best tempered, 25c.  
 ☞ Two springs for a buggy weigh about 28 lbs. If both 4 plate, 34 to 40 lbs.  
 Spokes, buggy, per set, \$4.20, or about 7c. each for all under 1½ in.  
 ☞ For extra hickory the charges are 8c. each.  
 Steel, Compound tire, from \$10 to \$10.50, according to thickness.  
 Stump-joints, per dozen, \$1.25 a \$1.75.  
 Tacks, 6c. and upwards per paper.  
 Tassels, holder, per pair, 63c. a \$1; inside, per dozen, \$3; acorn trigger, per dozen, \$1.25 a \$1.50.  
 Terry, per yard, \$7.  
 Top-props, Thos. pat., per set, 56c.; plain, com., 35c.  
 ☞ The patent props, with silver-plated nuts, per set, \$1.40.  
 Tufts, ball, per gross, 80c.; common worsted, 12c. a 25c.  
 Thread, Marshall & Co.'s Machine, No. 432, \$2.40 per lb; No. 532, \$2.75 do.; No. 632, \$3.50 do.  
 Turpentine, per gallon, \$4.  
 Twine, tufting, per ball, 31c.  
 Varnishes( Amer.), crown coach-body, \$5 a \$5.50; hard drying, \$6; nonpareil, \$6.50.  
 Do. English, \$6.25 in gold, or equivalent in currency on the day of purchase.  
 Do. American imitation of English, \$7.  
 Webbing, per piece, 56c.  
 Whiffle-trees, coach, turned, each, 25c.; per dozen, \$2.50.  
 Whiffle-tree spring hooks, \$3 per doz.  
 Whip-sockets, rubber, per dozen, \$7 a \$9; pat. leather, stitched, \$3.50.  
 Window lifter plates, per dozen, \$1.50.  
 Yokes, pole, each, 25c., per doz, \$2.50.  
 Yoke-tips, \$1.00 a \$1.50 per pr.

## PROSPECTUS OF THE SIXTH VOLUME.

*The only Coach-Maker's Magazine now published in the English Language!*

*On the 25th of May next, will be issued*

No. 1, Volume VI. of this Work for June.

In compliance with the wishes of the numerous friends of this periodical, we have concluded to go on with the regular publication thereof, confident that we shall receive (as we have always done) the generous support of the intelligent portion of the craft, to whose interests it has always been fearlessly and faithfully devoted. We shall not, therefore, waste ink in promises, since to do so would only be to repeat that which our readers already understand.

## TERMS OF SUBSCRIPTION.

In consequence of the enormous costs involved in the publication, we are obliged, for this volume, to charge single subscribers \$5, payment in advance. Single numbers, 50 cents. In clubs, two copies, \$9; three copies, \$13; six copies, \$21. Seven or more copies will be at the rate of \$3.25 per vol. Subscribers to pay their own postage, which is only three cents a quarter, if paid in advance, at the office to which the Magazine is mailed. No subscription booked until the money is received, and all terminate with the time for which payment is made.

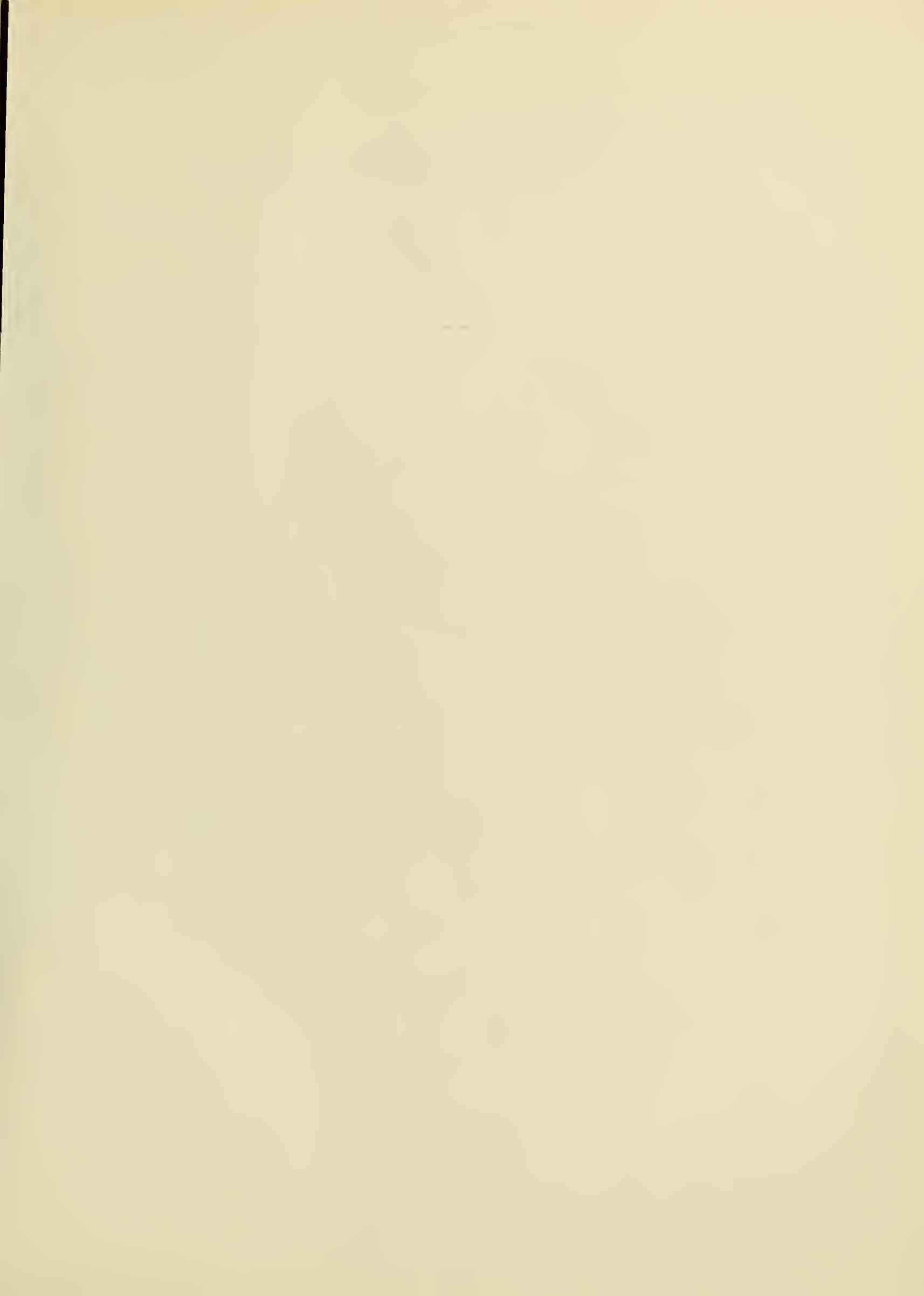











SMITHSONIAN INSTITUTION LIBRARIES



3 9088 01548 7713